

PARTS CATALOGUE

FZ-S



21CE



21CE PARTS CATALOGUE
INDIA YAMAHA MOTOR PVT. LTD.
1st edition, Mar 2012 All rights reserved.
Any reprinting or unauthorized use without the written permission of
INDIA YAMAHA MOTOR PVT. LTD. is expressly prohibited.
Printed in INDIA

FOREWORD

This Parts Catalogue is related to the parts in use for the YAMAHA - 21CE When you are ordering replacement parts for 21CE refer to this Parts Catalogue and quote both part numbers and part names correctly.

1. Modifications or additions which have been made after issue of the Parts Catalogue will be announced in the Service Actions. It is advisable that according to the Service Action you make necessary corrections to the Parts Catalogue on hand to keep it up-to-date.
2. Indication of No. of constituent parts for assembly.
The numeral appearing to the right of each constituent part under the description indicates the quantity of such parts for each individual assembly unit.

EXAMPLE

Part No.	Description	Qty
21C-E1400-09	CRANK SHAFT ASSY.	1
35B-H2100-00	BATTERY ASSY	1
90445-08336	HOSE	1
54B-E1111-00	CYLINDER HEAD	1

3. Applicable Serial No. and Color Code

1	Frame Serial No	XXX	21CE	X	E	X	X	X	xxxxxx
		Mfr Code	Model Code	Prod No Code	Variant Code	Month Code	Year Code	Factory Code	Serial No
2	Frame Serial No		21CE	xxxxxx					
			Model Code	Serial No.					

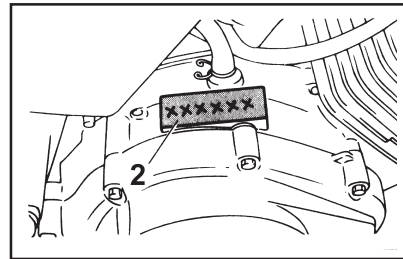
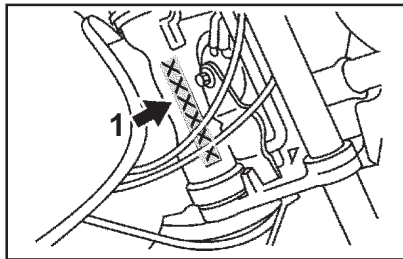

Colour Code	Colour Name	Abbreviation
0033	YAMAHA BLACK	YB
0033	YAMAHA BLACK (with Green Parts)	YB
0121	VIVID RED COCKTAIL 1	VRC1
0390	BLUISH WHITE COCKTAIL 1	BWC1

NOTICE

The description and illustration in this Parts Catalogue may not necessarily match with the physical appearance of the parts.

INDIA YAMAHA MOTOR PVT. LTD. reserves the right to carry out modifications on the vehicle, parts or accessories, as may be considered necessary, without being obliged to update this Parts Catalogue immediately.

No part of this Publication may be reproduced without written permission of INDIA YAMAHA MOTOR PVT. LTD.
Spare Parts Division

1. Parts number Structure
1) Common parts number

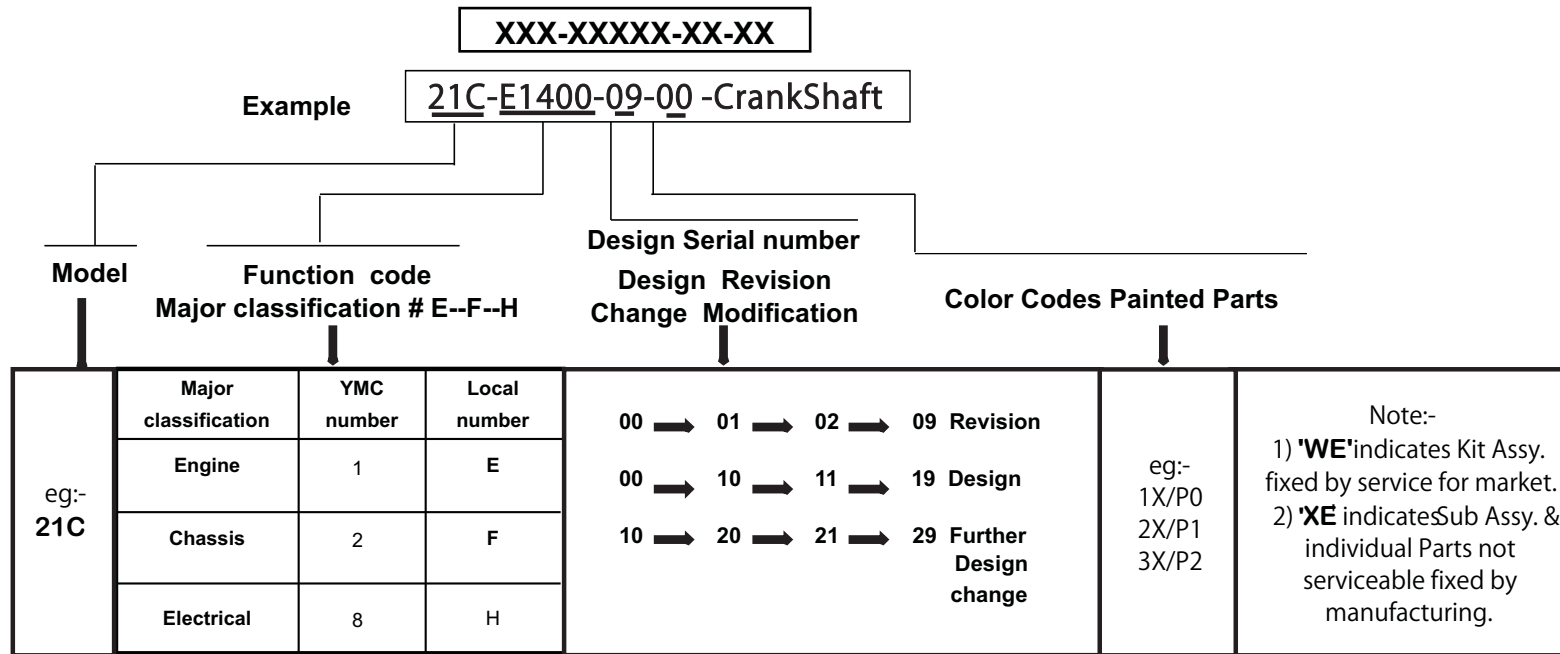

Note:- Only Colored parts are 12 digit in Catalog - Rest are 10 Digits(Non-Coloured Parts)

2) Standard parts number /Regular parts number

Standard parts number ;

9XX-XXXXXXX

→ Type of Parts Ex:-

- 947XX=Plug spark
- 932XX="O" Ring
- 985XX=Screw pan head

Regular parts number ;

9XXXX-XXXXX

Category Code Ex:-

- 901XX=Bolt and Nut
- 902XX=Washer and Rivet
- 903XX=Bush and Collor
- 904XX=Hose and Clamp
- 905XX=Spring and spacer

CONTENTS

ENGINE

CYLINDER	2
CRANKSHAFT/PISTON	3
VALVE	4
CAMSHAFT/CHAIN	5
OIL PUMP	6
INTAKE	7
CARBURETTOR	9
EXHAUST	11
CRANKCASE	12
CRANKCASE COVER 1	13
STARTER	14
STARTER CLUTCH	15
CLUTCH	16
TRANSMISSION	17
SHIFT CAM FORK	18
SHIFT SHAFT	19

CHASSIS

FRAME	20
FENDER	21
SIDE COVER	22
REAR ARM. & SUSPENSION	23
STEERING	24
FRONT FORK	25
FUEL TANK	27

FUEL TANK 2	29
SEAT	30
FRONT WHEEL	31
FRONT BRAKE CALIPER.....	32
REAR WHEEL	33
STEERING HANDLE & CABLE	35
FRONT MASTER CYLINDER	36
STAND FOOTREST	37
STAND 2, FOOTREST	39
GENERATOR	40
STARTER MOTOR	41
FLASHER LIGHT	42
METER	44
HEAD LIGHT	45
TAILLIGHT	46
HANDLE SWITCH & LEVER	47
ELECTRICAL 1	48
ELECTRICAL 2	49

NUMERICAL INDEX

FIG. 1 (1) CYLINDER

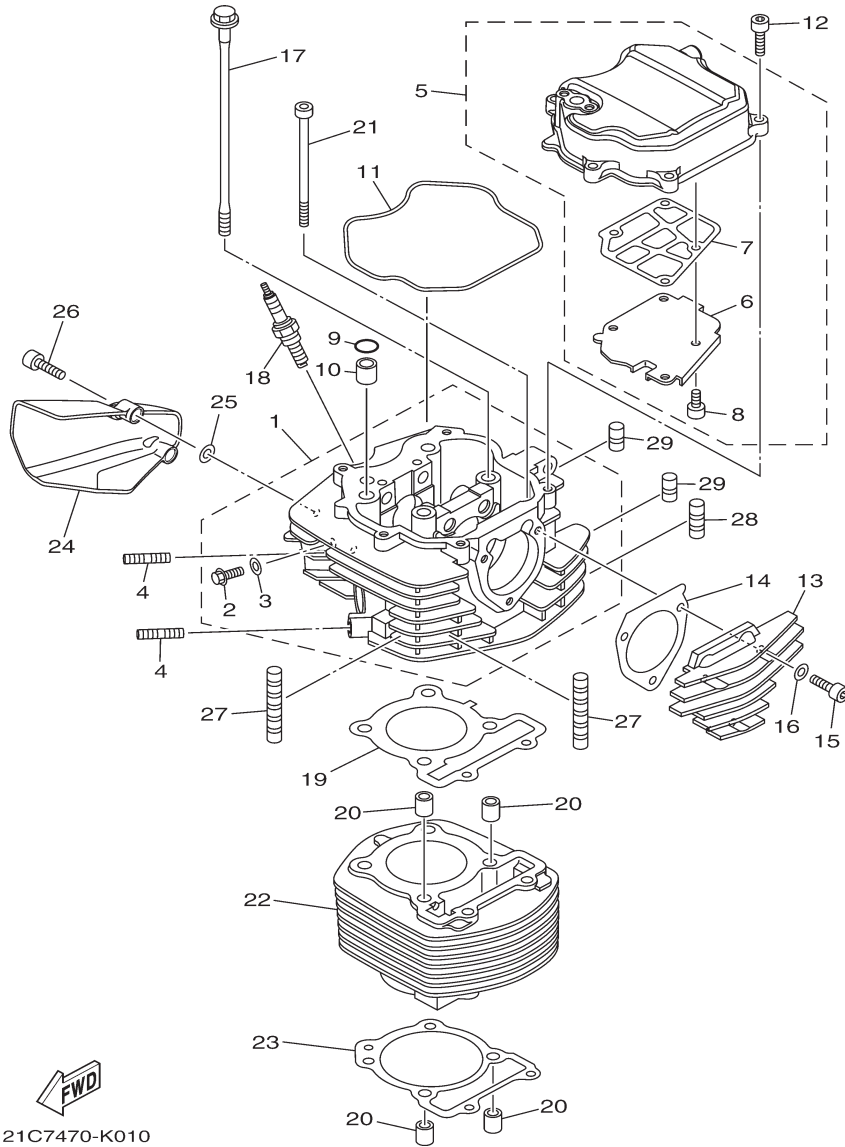

21C7470-K010

REF. NO.	PART NO.	PART NAME	21CE				REMARKS
1	54B-E1111-00	HEAD, CYLINDER 1	1				UR
	54B-E1111-10	HEAD, CYLINDER 1	1				UR
2	95022-06012	.BOLT, FLANGE	1				
3	90430-06014	.GASKET	1				
4	95617-08620	BOLT, STUD	2				
5	1PM-E1190-00	COVER, CYLINDER HEAD 1	1				
6	1PM-E1165-00	.PLATE, BREATHER	1				
7	54B-E1169-00	.GASKET, BREATHER COVER	1				
8	91317-05010	.BOLT	4				
9	93210-12800	O-RING	1				
10	93612-16254	PIN, DOWEL	1				
11	21C-E1193-00	GASKET, HEAD COVER 1	1				
12	91317-06025	BOLT	5				
13	54B-E1186-00	COVER, CYLINDER HEAD SIDE 2	1				
14	54B-E2435-00	GASKET	1				
15	91317-06025	BOLT	3				
16	90430-06014	GASKET	3				
17	90105-08197	BOLT, FLANGE	4				
18	94703-00885	PLUG, SPARK (NGK CPR8EA)	1				
19	54B-E1181-00	GASKET, CYLINDER HEAD 1	1				
20	91810-14804	PIN, DOWEL	4				
21	90110-06304	BOLT, HEXAGON SOCKET HEAD	2				
22	54B-E1310-00	CYLINDER	1				
23	21C-E1351-00	GASKET, CYLINDER	1				
24	21C-E2661-10	DUCT	1				
25	90201-05015	WASHER, PLATE	2				
26	90110-06846	BOLT, HEXAGON SOCKET HEAD	2				
27	21C-E1161-00	ABSORBER 1	2				
28	21C-E1161-10	ABSORBER 1	1				
29	21C-E1161-20	ABSORBER 1	2				

FIG. 2 (110) CRANKSHAFT & PISTON

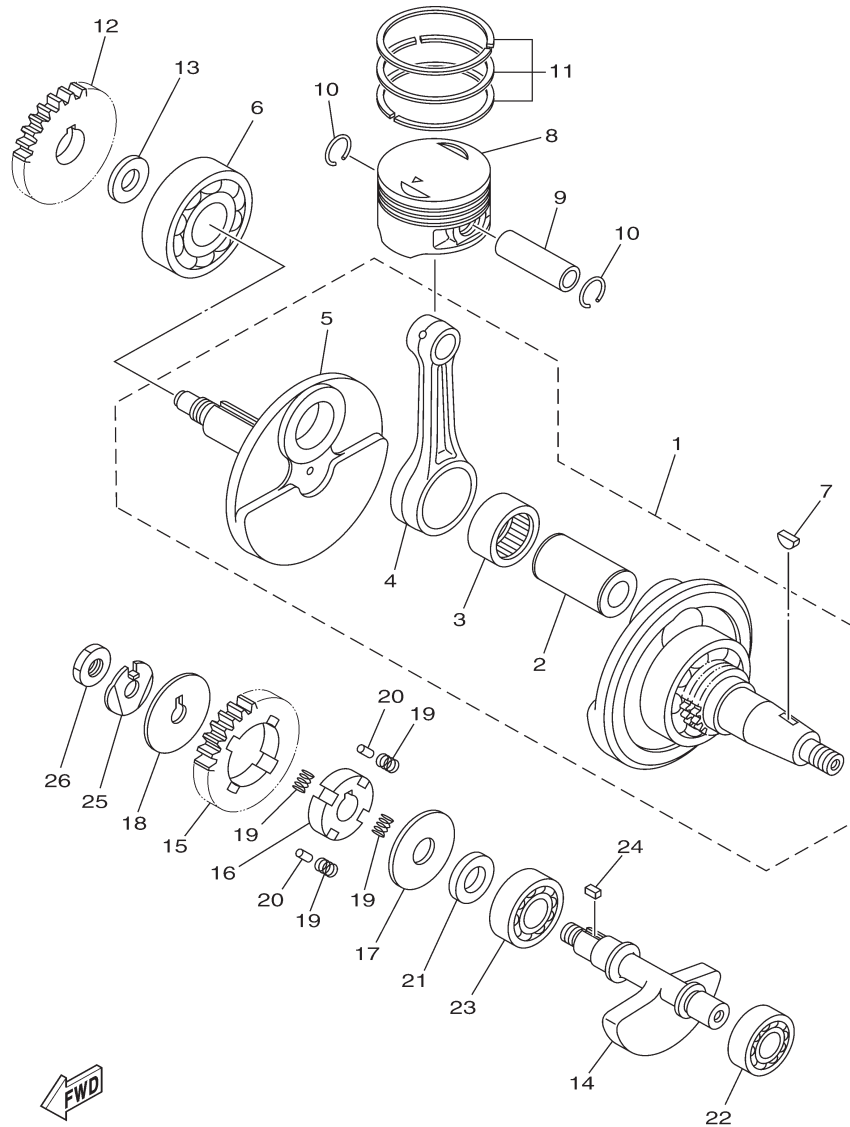

21C7470-K020

REF. NO.	PART NO.	PART NAME	21CE				REMARKS
1	21C-E1400-09	CRANKSHAFT ASSY	1				
2	21C-E1681-01	.PIN, CRANK 1	1				
3	93310-628X0	.BEARING	1				
4	21C-E1651-00	.ROD, CONNECTING	1				
5	21C-E1422-00	.CRANK 2	1				
6	93306-305YR	BEARING	1				
7	90280-03017	KEY, WOODRUFF	1				
8	21C-E1631-00	PISTON (STD)	1				
	21C-E1636-09	PISTON (0.50MM O/S)	1				AP
	21C-E1638-09	PISTON (1.00MM O/S)	1				AP
9	21C-E1633-00	PIN, PISTON	1				
10	93450-16812	CIRCLIP	2				
11	21C-E1603-00	PISTON RING SET (STD)	1				
	21C-E1605-00	PISTON RING SET (0.50MM O/S)	1				AP
	21C-E1607-00	PISTON RING SET (1.00MM O/S)	1				AP
12	54B-E1536-00	GEAR, DRIVE	1				
13	90387-20813	COLLAR	1				
14	54B-E1454-00	WEIGHT 1	1				
15	21C-E1531-00	GEAR, BALANCE WEIGHT	1				
16	21C-E1496-20	BOSS, BUFFER	1				
17	90201-15022	WASHER, PLATE	1				
18	90214-10006	WASHER, CLAW	1				
19	54B-E1476-00	SPRING	4				
20	21C-E3362-00	ROLLER	2				
21	90387-155J0	COLLAR	1				
22	93306-252YG	BEARING	1				
23	93306-253Y6	BEARING	1				
24	90282-05031	KEY, STRAIGHT	1				
25	90215-10284	WASHER, LOCK	1				
26	90170-10405	NUT	1				

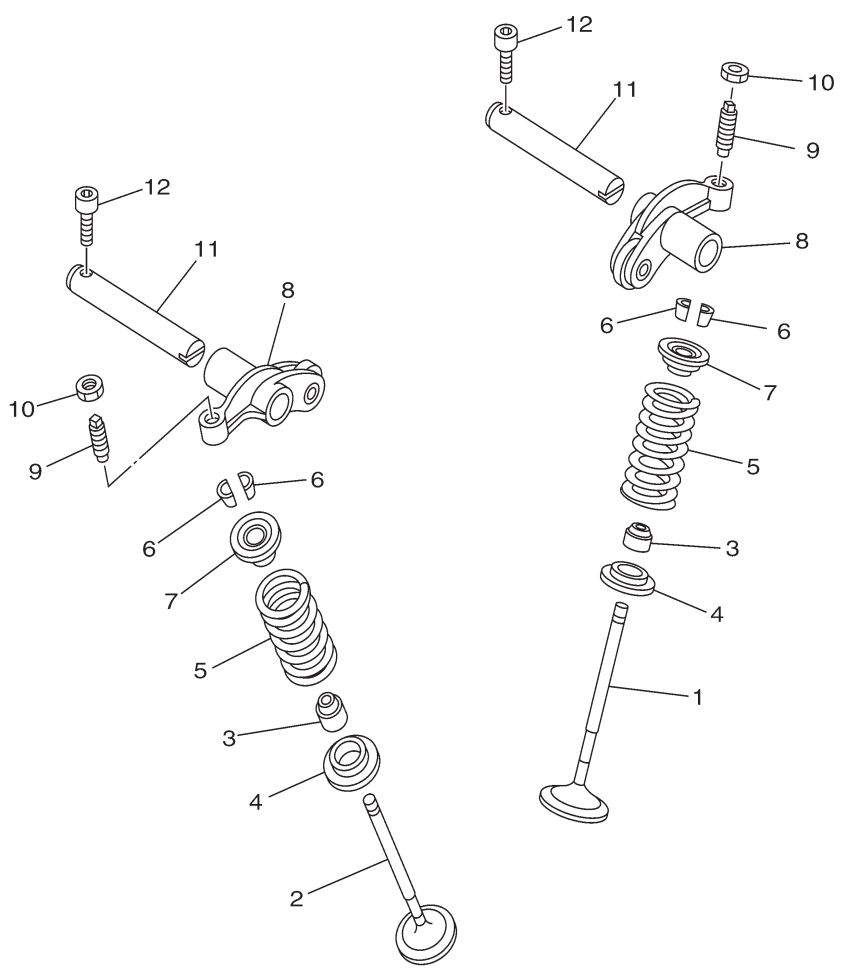

FIG. 3 (1M0) VALVE

REF. NO.	PART NO.	PART NAME	21CE				REMARKS
1	54B-E2111-00	VALVE, INTAKE	1				
2	54B-E2121-00	VALVE, EXHAUST	1				
3	21C-E2119-00	SEAL, VALVE STEM	2				
4	21C-E2126-00	SEAT, VALVE SPRING 2	2				
5	21C-E2113-00	SPRING, VALVE INNER	2				
6	22F-12118-01	COTTER, VALVE	4				
7	21C-12117-00	RETAINER, VALVE SPRING	2				
8	21C-E2151-00	ARM, VALVE ROCKER	2				
9	21C-12159-00	SCREW, VALVE ADJUSTING	2				
10	90170-06128	NUT	2				
11	21C-E2156-00	SHAFT, ROCKER 2	2				
12	91317-05016	BOLT	2				



21C1470-G030

FIG. 4 (1N0) CAMSHAFT & CHAIN

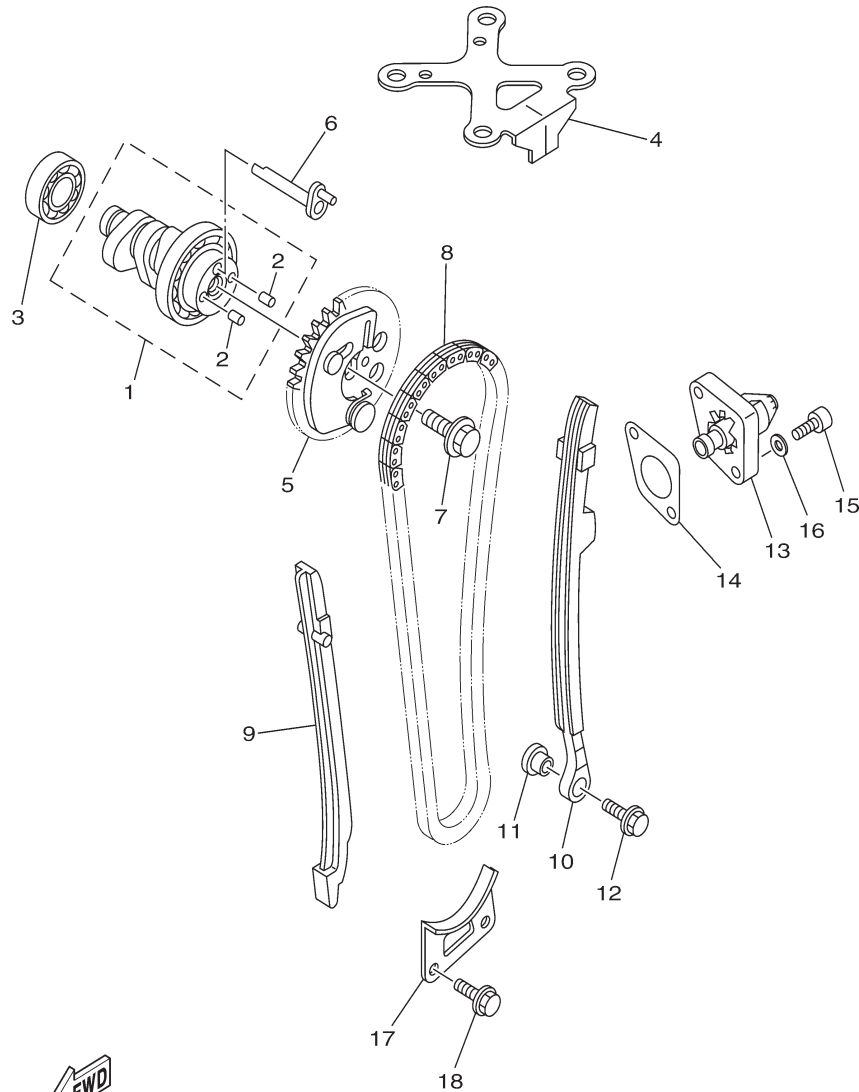

54B1470-J040

REF. NO.	PART NO.	PART NAME	21CE				REMARKS
1	21C-E2170-00	CAMSHAFT ASSY 1	1				
2	93605-06800	.PIN, DOWEL	2				
3	93306-002X2	BEARING	1				UR
	93306-002Y1	BEARING	1				UR
4	21C-E111F-00	PLATE	1				
5	1PM-E2280-00	DECOMPRESSION ASSY	1				
6	1PM-E2288-00	CAM, DECOMPRESSION	1				
7	90105-08196	BOLT, FLANGE	1				
8	94568-G2096	CHAIN	1				
9	21C-E2231-00	GUIDE, STOPPER 1	1				
10	21C-E2241-00	GUIDE, STOPPER 2	1				
11	4LS-E5598-00	COLLAR	1				
12	95802-06020	BOLT, FLANGE	1				
13	21C-E2210-00	TENSIONER ASSY, CAM CHAIN	1				
14	5MX-E2213-01	GASKET, TENSIONER CASE	1				
15	91317-06018	BOLT	2				
16	90201-06037	WASHER, PLATE (T=1.0)	2				
17	21C-E2437-00	STOPPER	1				
18	95027-06016	BOLT, FLANGE	2				

FIG. 5 (2C0) OIL PUMP

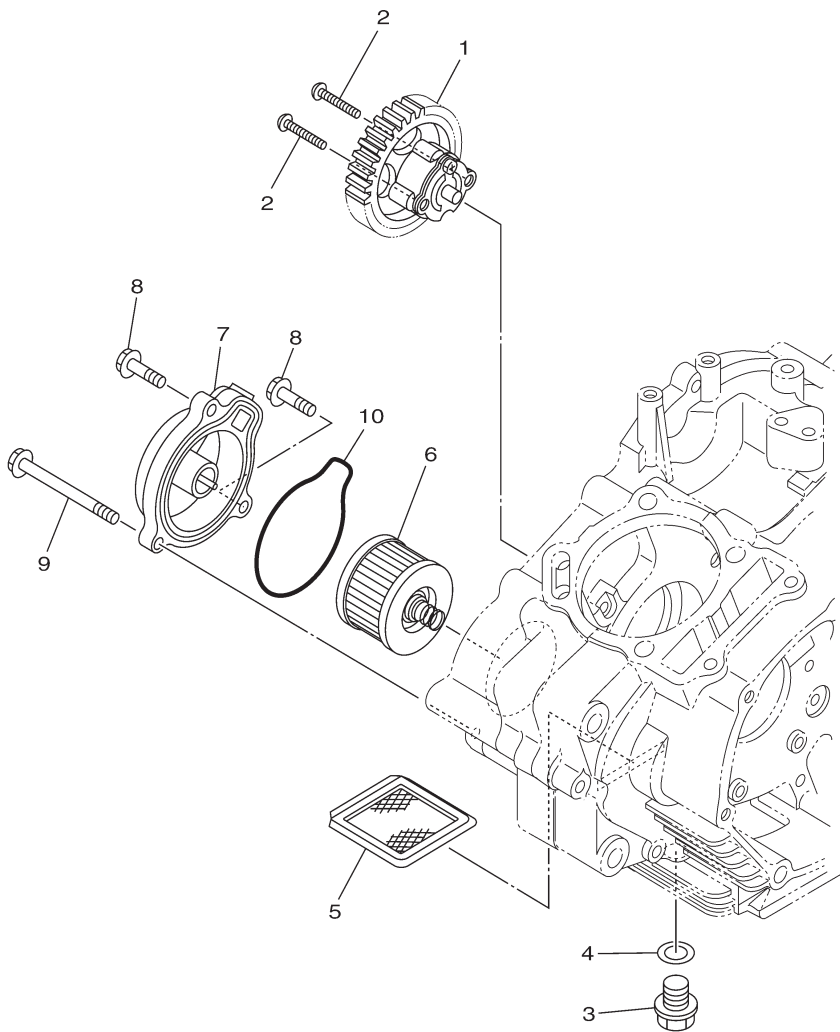

REF. NO.	PART NO.	PART NAME	21CE				REMARKS
1	54B-E3300-00	OIL PUMP ASSY	1				
2	90111-05808	BOLT,HEX. SOCKET BUTTON	2				
3	90340-12097	PLUG, STRAIGHT SCREW	1				
4	90430-12227	GASKET	1				
5	4LS-E3411-00	STRAINER, OIL	1				
6	21C-E3440-00	ELEMENT ASSY, OIL CLEANER	1				
7	21C-E3447-00	COVER, OIL ELEMENT	1				
8	95027-06020	BOLT, FLANGE	2				
9	95027-06065	BOLT, FLANGE	1				
10	21C-E3449-00	GASKET, ELEMENT COVER	1				



1PM1470-L050

FIG. 6 (2J0) INTAKE

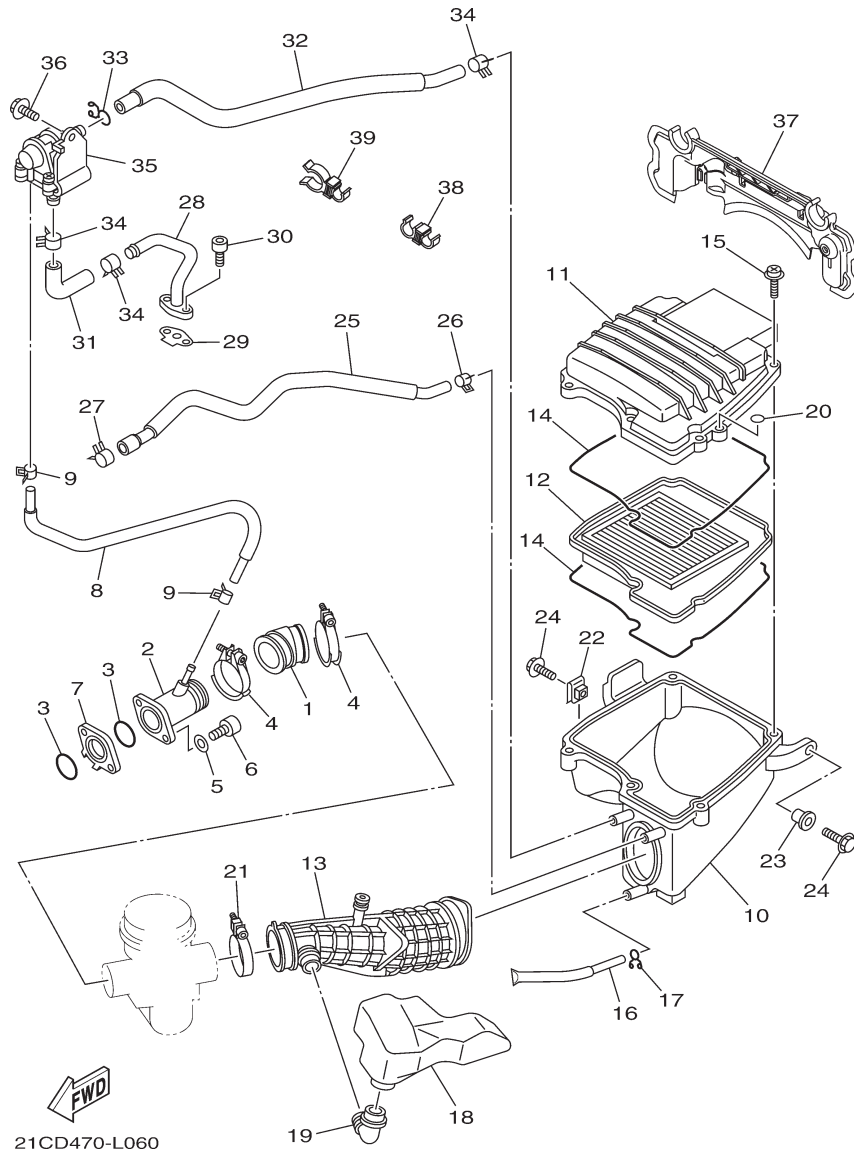

REF. NO.	PART NO.	PART NAME	21CE				REMARKS
1	21C-E3586-01	JOINT, CARBURETOR 1	1				
2	21C-E3536-01	JT., CARBURETOR	1				
3	93210-30611	O-RING	2				
4	90450-44803	HOSE CLAMP ASSY	2				
5	92907-06600	WASHER, PLATE	2				
6	91317-06025	BOLT	2				
7	21C-E3595-00	JOINT	1				
8	21C-E3542-00	HOSE, VACUUM SENSING 1	1				
9	90467-08808	CLIP	2				
10	21C-E4411-00	CASE, AIR CLEANER 1	1				
11	21C-E4412-00	CAP, CLEANER CASE 1	1				
12	21C-E4450-00	ELEMENT ASSY, AIR CLEANER	1				
13	21C-E4453-00	JOINT, AIR CLEANER 1	1				
14	21C-E4452-00	SEAL	2				
15	97602-05320	SCREW, PAN HEAD WITH WASHER	5				
16	21C-E443E-00	PIPE, DRAIN	1				
17	90467-12800	CLIP	1				
18	21C-E4877-00	RESONATOR	1				
19	21C-E4485-00	PIPE, JOINT	1				
20	21C-E446R-00	SEAL	1				
21	90450-50802	HOSE CLAMP ASSY	1				
22	90183-06802	NUT, SPRING	1				
23	90387-06737	COLLAR	1				
24	95827-06016	BOLT, FLANGE	2				
25	21C-E1166-10	PIPE, BREATHER 1	1				
26	90467-13816	CLIP	1				
27	90467-16805	CLIP	1				
28	21C-E4872-00	PIPE 2	1				
29	21C-E4815-00	GASKET	1				
30	91317-06016	BOLT	2				

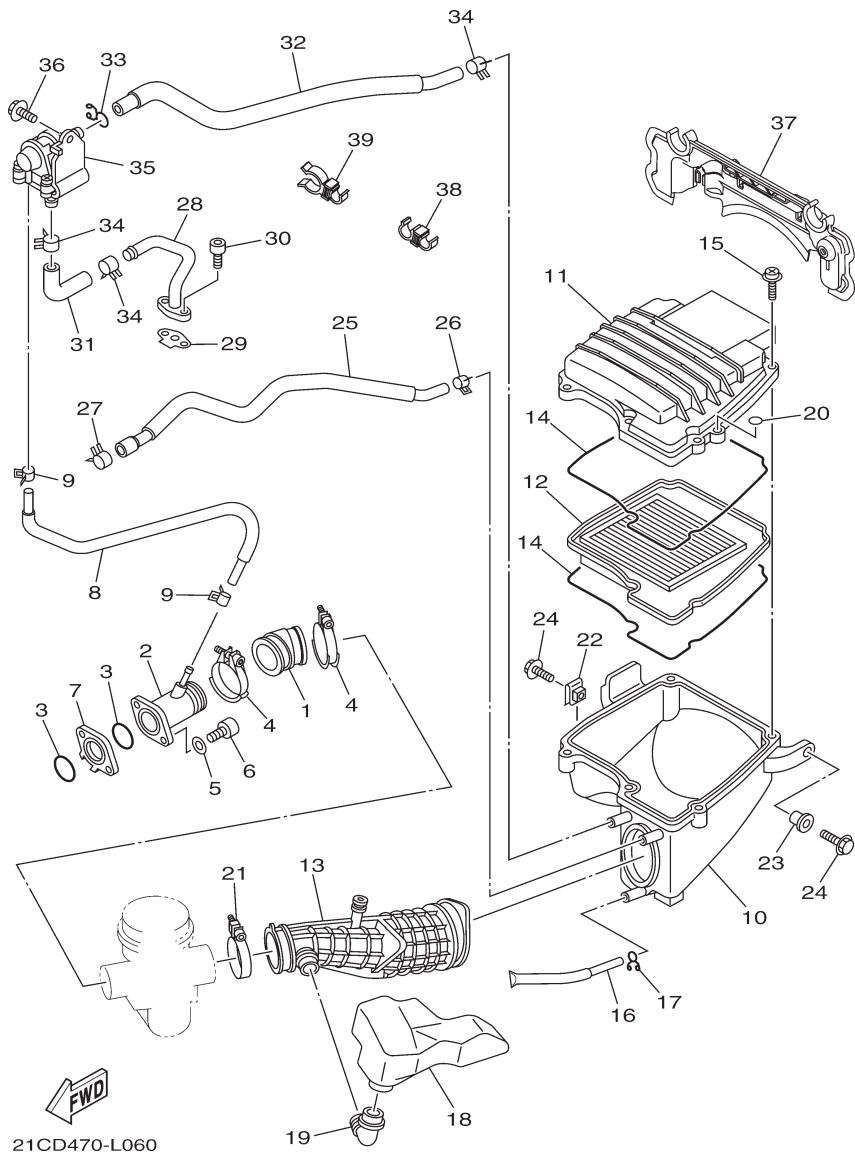
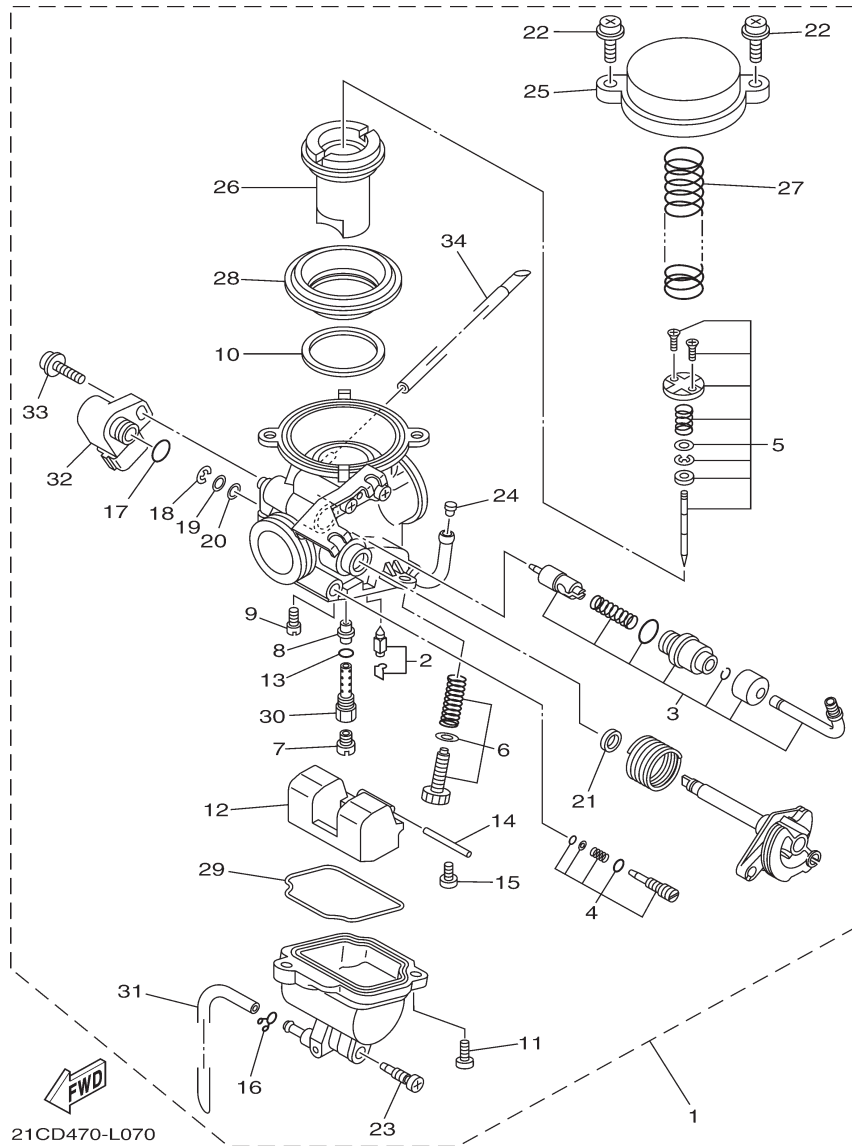

FIG. 6 (2J0) INTAKE

REF. NO.	PART NO.	PART NAME	21CE				REMARKS
31	21C-E4881-00	HOSE, BEND 1	1				
32	21C-E4882-00	HOSE, BEND 2	1				
33	90467-15012	CLIP	1				
34	90467-16805	CLIP	3				
35	45P-E4803-10	AIR INDUCTION SYSTEM ASSY	1				
36	95827-06012	BOLT, FLANGE	1				
37	21C-E449E-10	COVER, AIR CLEANER	1				
38	90464-11014	CLAMP	1				
39	90464-16016	CLAMP	1				

FIG 7 (2K0) CARBURETOR



REF. NO.	PART NO.	PART NAME	21CE				REMARKS
1	21C-E4901-40	CARBURETOR ASSY 1	1				
2	5YY-14150-00	.NEEDLE ASSY	1				
3	21C-1410A-10	.STARTER SET	1				
4	21C-14105-00	.PILOT SCREW SET	1				
5	21C-1490J-10	.NEEDLE SET	1				
6	21C-14103-00	.THROTTLE SCREW SET	1				
7	3G2-1423A-73	.JET, MAIN (#112.5)	1				
8	21C-1414M-41	.NOZZLE, MAIN	1				
9	INT-14142-15	.JET, PILOT (# 15)	1				
10	5GH-14918-10	.RING	1				
11	98502-05012	.SCREW, PAN HEAD	2				
12	54B-14985-00	.FLOAT	1				
13	583-14561-00	.O-RING	1				
14	353-14186-00	.PIN, FLOAT	1				
15	98507-04008	.SCREW, PAN HEAD	1				
16	22F-14139-00	.CLIP, PIPE	1				
17	5YP-14561-00	.O-RING	1				
18	22F-14137-00	.CLIP	1				
19	22F-14953-00	.WASHER	1				
20	6K8-14597-10	.WASHER	1				
21	2A2-14997-00	.SEAL	1				
22	4KM-14216-00	.SCREW	2				
23	21C-14191-00	.PLUG, DRAIN	1				
24	5LW-14994-00	.NET, FILTER	1				
25	21C-14958-10	.COVER, DIAPHRAGM	1				
26	21C-14340-00	.VALVE ASSY	1				
27	21C-14275-00	.SPRING	1				
28	21C-14545-00	.DIAPHRAGM	1				
29	21C-14147-00	.O-RING	1				
30	21C-1496A-00	.HOLDER, NEEDEL JET	1				

FIG. 7 (2K0) CARBURETOR

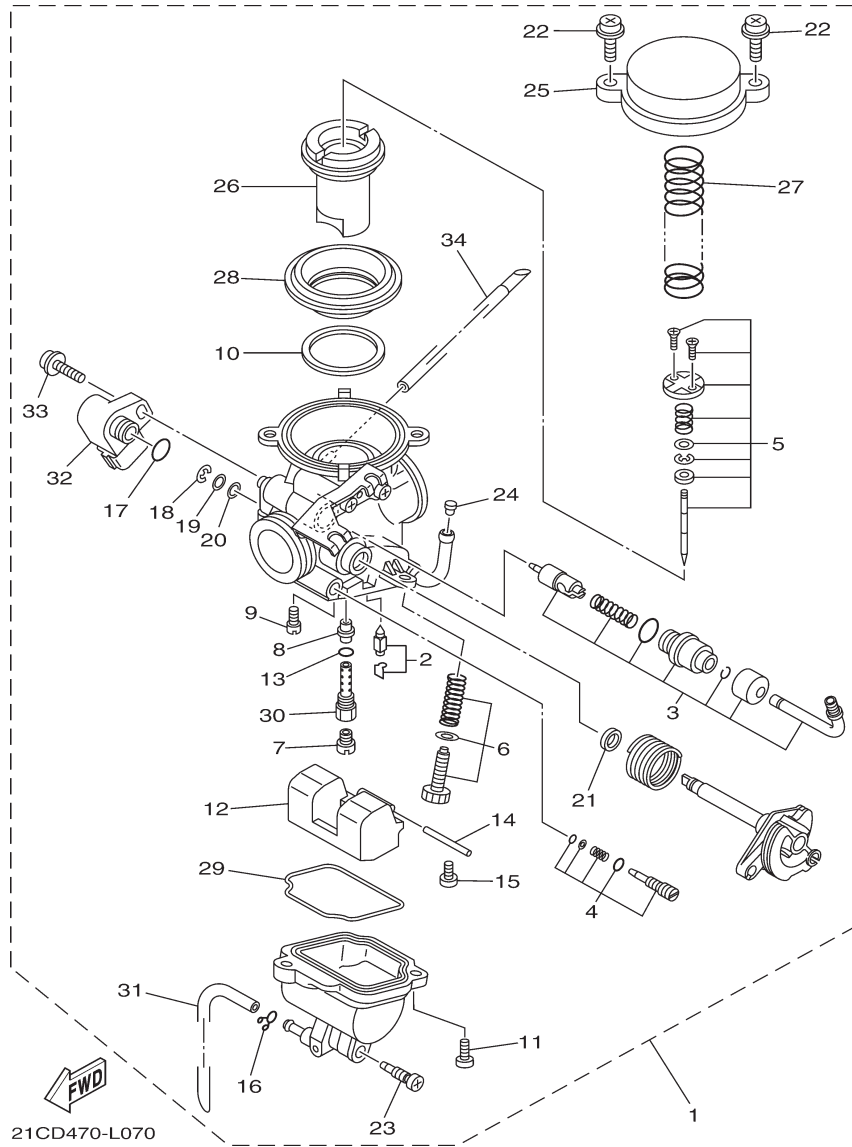

REF. NO.	PART NO.	PART NAME	21CE				REMARKS
31	21C-14987-00	.HOSE	1				
32	21C-85885-00	.THROTTLE SENSOR ASSY	1				
33	21C-14216-00	.SCREW	1				
34	21C-1410E-10	.HOSE	1				

FIG. 8 (2N0) EXHAUST

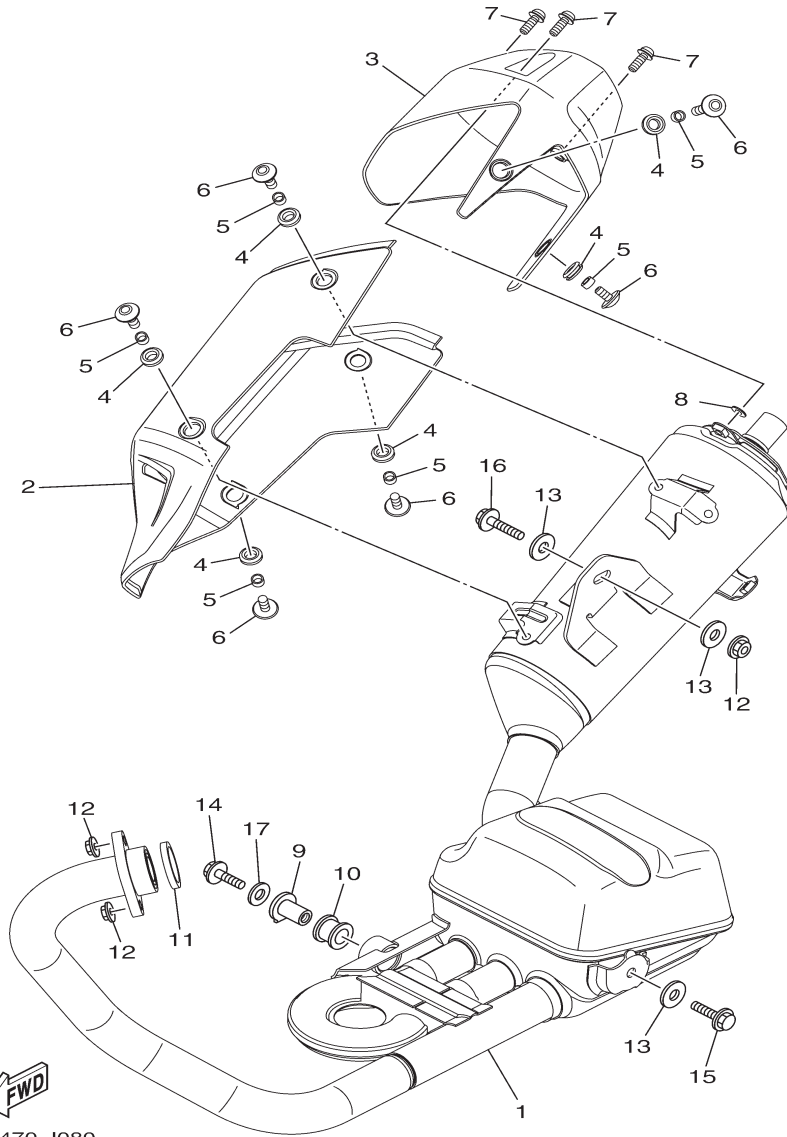

45S1470-J080

REF. NO.	PART NO.	PART NAME	21CE				REMARKS
1	21C-E4703-10	MUFFLER COMP. 1	1				
2	21C-E4718-10	PROTECTOR, MUFFLER 1	1				
3	21C-E4799-01	CAP	1				
4	90480-12581	GROMMET	6				
5	90387-06023	COLLAR	6				
6	90111-06087	BOLT,HEX. SOCKET BUTTON	6				
7	90111-06807	BOLT,HEX. SOCKET BUTTON	3				
8	90202-05807	WASHER, PLATE	3				
9	21C-E4775-00	NUT	1				
10	20P-E4747-00	DAMPER, MUFFLER	1				
11	21C-E4613-00	GASKET, EXHAUST PIPE	1				
12	95707-08500	NUT, FLANGE	3				
13	90201-08612	WASHER, PLATE	3				
14	95807-08025	BOLT, FLANGE	1				
15	95807-08035	BOLT, FLANGE	1				
16	95817-08040	BOLT, FLANGE	1				
17	90201-087F0	WASHER, PLATE	1				

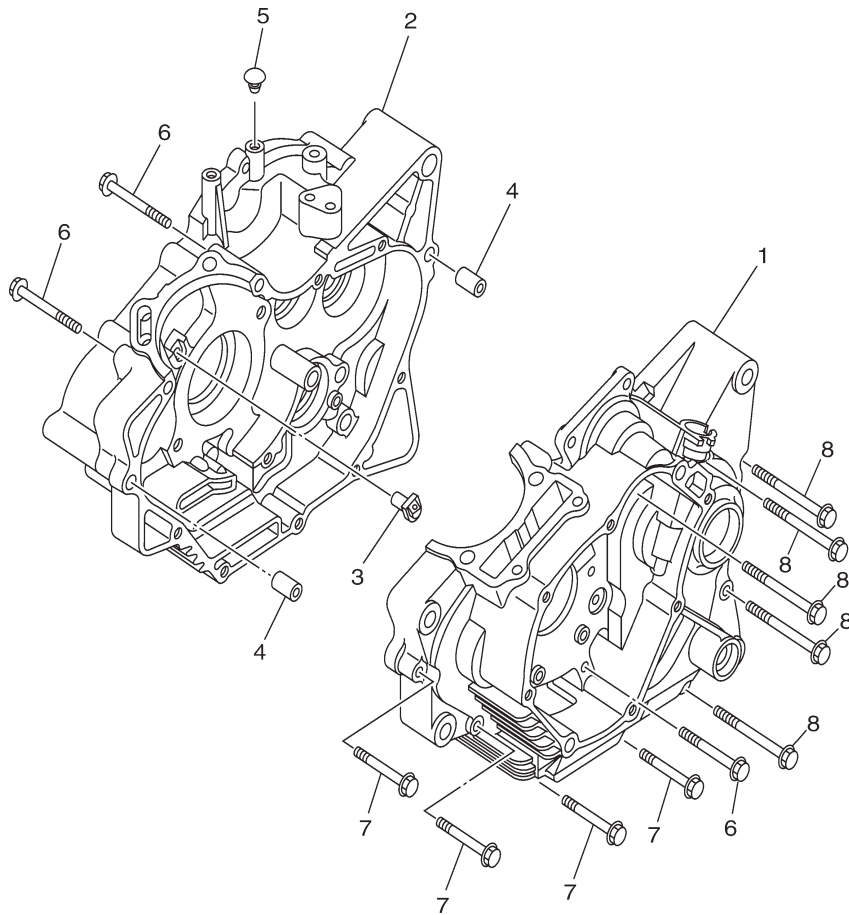
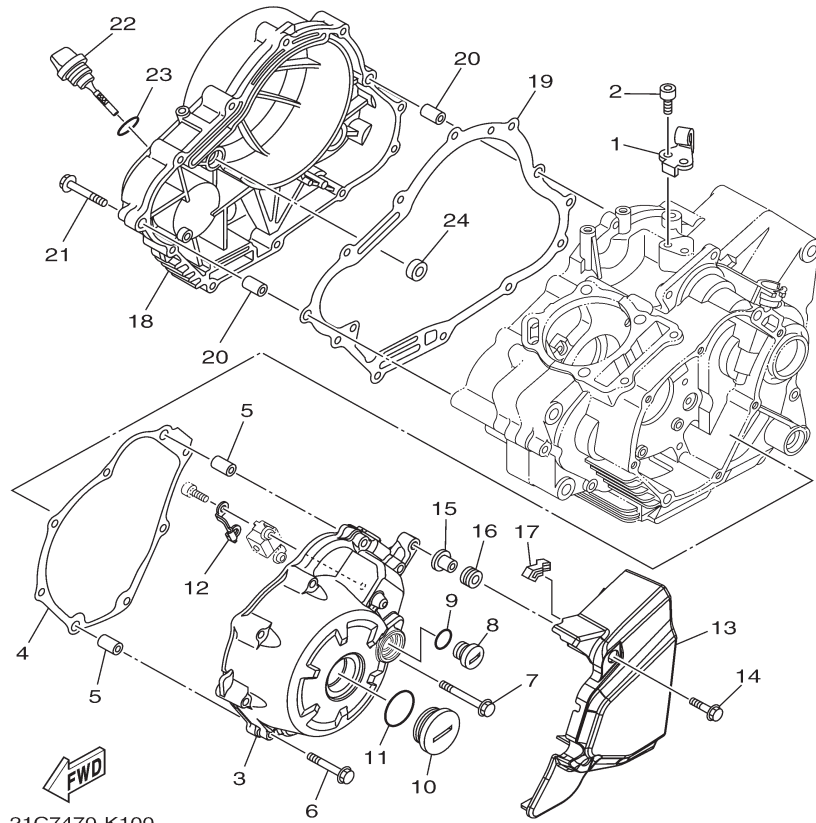
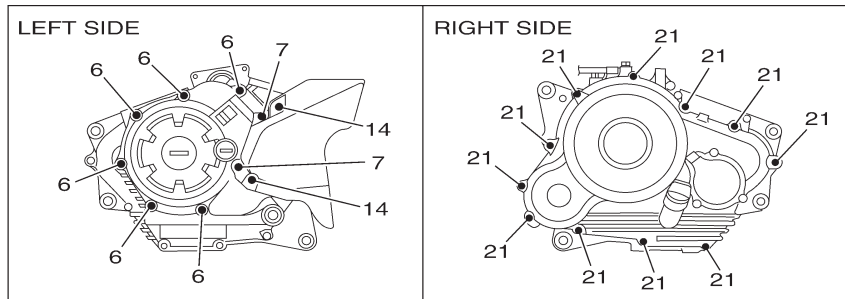

FIG. 9 (2R0) CRANKCASE

REF. NO.	PART NO.	PART NAME	21CE				REMARKS
1	54B-E5111-00	CRANKCASE 1	1				
2	54B-E5121-00	CRANKCASE 2	1				
3	21C-E5155-00	NOZZLE 3	1				
4	91830-21014	PIN, DOWEL	2				
5	90338-05801	PLUG	1				
6	95027-06055	BOLT, FLANGE	3				
7	95027-06045	BOLT, FLANGE	4				
8	95027-06070	BOLT, FLANGE	5				



54B2470-J090



21C7470-K100

FIG. 10 (2S0) CRANKCASE COVER 1

REF. NO.	PART NO.	PART NAME	21CE				REMARKS
1	21C-E5441-00	HOLDER, CLUTCH CABLE	1				
2	91317-06014	BOLT	2				
3	21C-E5411-10	COVER, CRANKCASE 1	1				
4	54B-E5451-00	GASKET, CRANKCASE COVER 1	1				
5	91830-21014	PIN, DOWEL	2				
6	95027-06040	BOLT, FLANGE	6				
7	95027-06050	BOLT, FLANGE	2				
8	90340-14824	PLUG, STRAIGHT SCREW	1				
9	93210-14899	O-RING	1				
10	90340-32823	PLUG, STRAIGHT SCREW	1				
11	93210-32814	O-RING	1				
12	21C-E5113-00	PLATE	1				
13	21C-E5418-01	COVER, CHAIN CASE	1				
14	95807-06020	BOLT, FLANGE	2				
15	90387-068C9	COLLAR	2				
16	90480-12812	GROMMET	2				
17	21C-E542A-00	DAMPER 1	1				
18	21C-E5421-00	COVER, CRANKCASE 2	1				
19	54B-E5461-00	GASKET, CRANKCASE COVER 2	1				
20	91830-21014	PIN, DOWEL	2				
21	95027-06040	BOLT, FLANGE	11				
22	54B-E5362-00	PLUG, OIL LEVEL	1				
23	93210-19809	O-RING	1				
24	93101-10838	OIL SEAL	1				

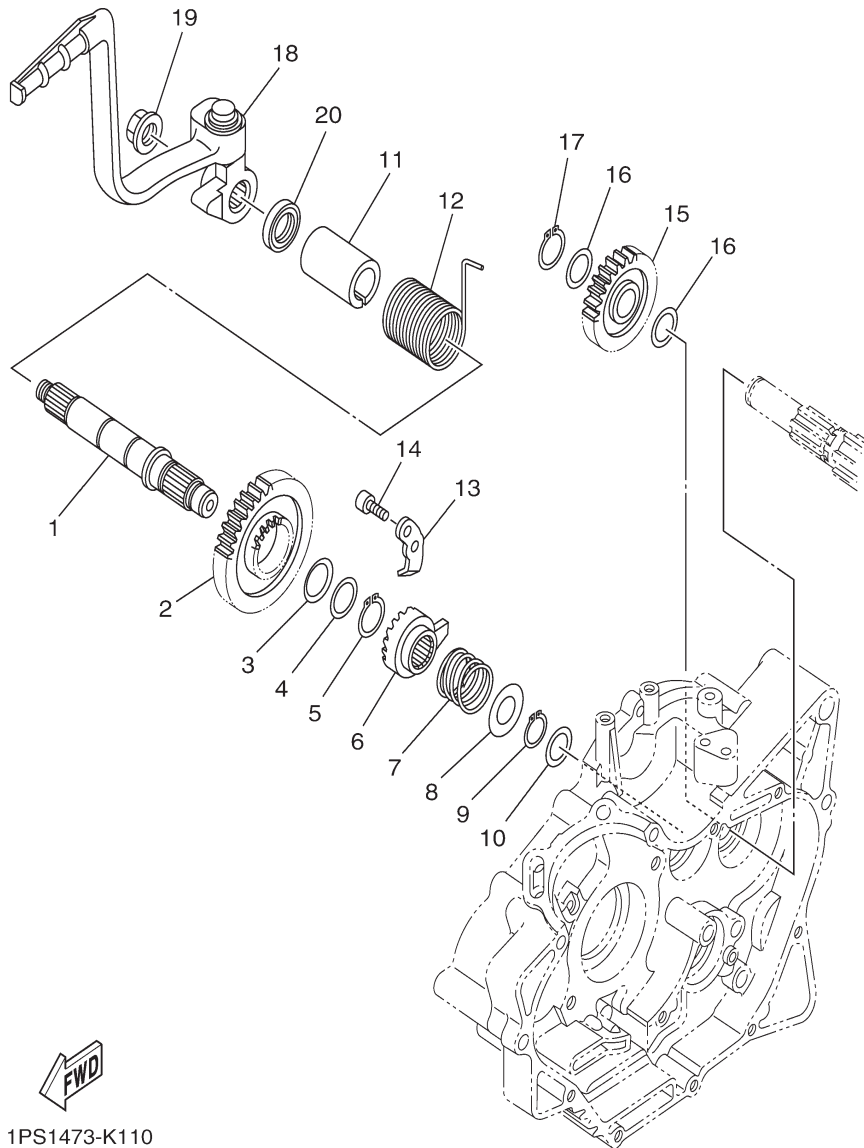

1PS1473-K110

FIG. 11 (2U0) STARTER

REF. NO.	PART NO.	PART NAME	21CE				REMARKS
1	54B-E5661-00	AXLE, KICK	1				
2	21C-E5641-10	GEAR, KICK	1				
3	90208-20005	WASHER, CONICAL SPRING	1				
4	90201-20685	WASHER, PLATE (T=0.5)	1				
5	93410-20038	CIRCLIP	1				
6	21C-E5671-00	WHEEL, RATCHET	1				
7	21C-E5767-00	SPRING	1				
8	90201-167P7	WASHER, PLATE	1				
9	99009-16400	CIRCLIP	1				
10	90201-162H4	WASHER, PLATE	1				
11	54B-E5664-10	GUIDE, SPRING	1				
12	54B-E5665-00	SPRING, KICK	1				
13	21C-E5674-00	GUIDE, RATCHET WHEEL	1				
14	91317-06016	BOLT	2				
15	45P-E5651-00	GEAR, KICK IDLE	1				
16	90201-177G4	WASHER, PLATE	2				
17	99009-17400	CIRCLIP	1				
18	21C-E5620-00	KICK CRANK ASSY	1				
19	90179-12659	NUT	1				
20	93109-20821	OIL SEAL	1				

FIG. 12 (2V0) STARTER CLUTCH

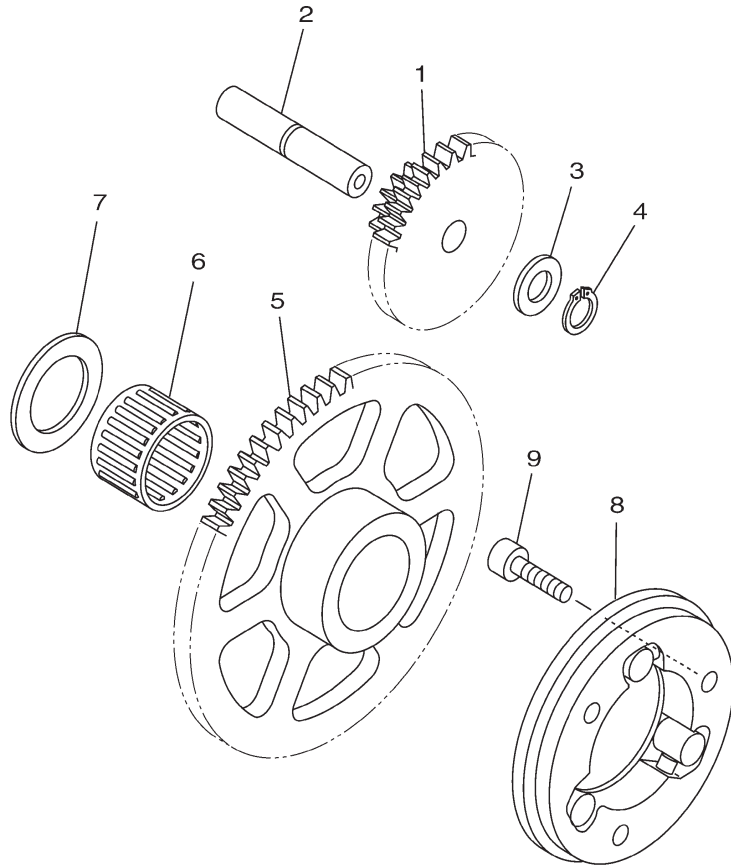

REF. NO.	PART NO.	PART NAME	21CE				REMARKS
1	21C-E5514-10	GEAR 2	1				
2	21C-E5521-00	SHAFT 1	1				
3	90201-105E8	WASHER, PLATE	1				
4	99009-10400	CIRCLIP	1				
5	1PM-E5524-00	WHEEL, STARTER	1				
6	93310-325X3	BEARING	1				
7	90201-25290	WASHER, PLATE	1				
8	54B-E5580-00	STARTER CLUTCH OUTER ASSY	1				
9	91312-06020	BOLT	3				



1PS1473-K120

FIG. 13 (2X0) CLUTCH

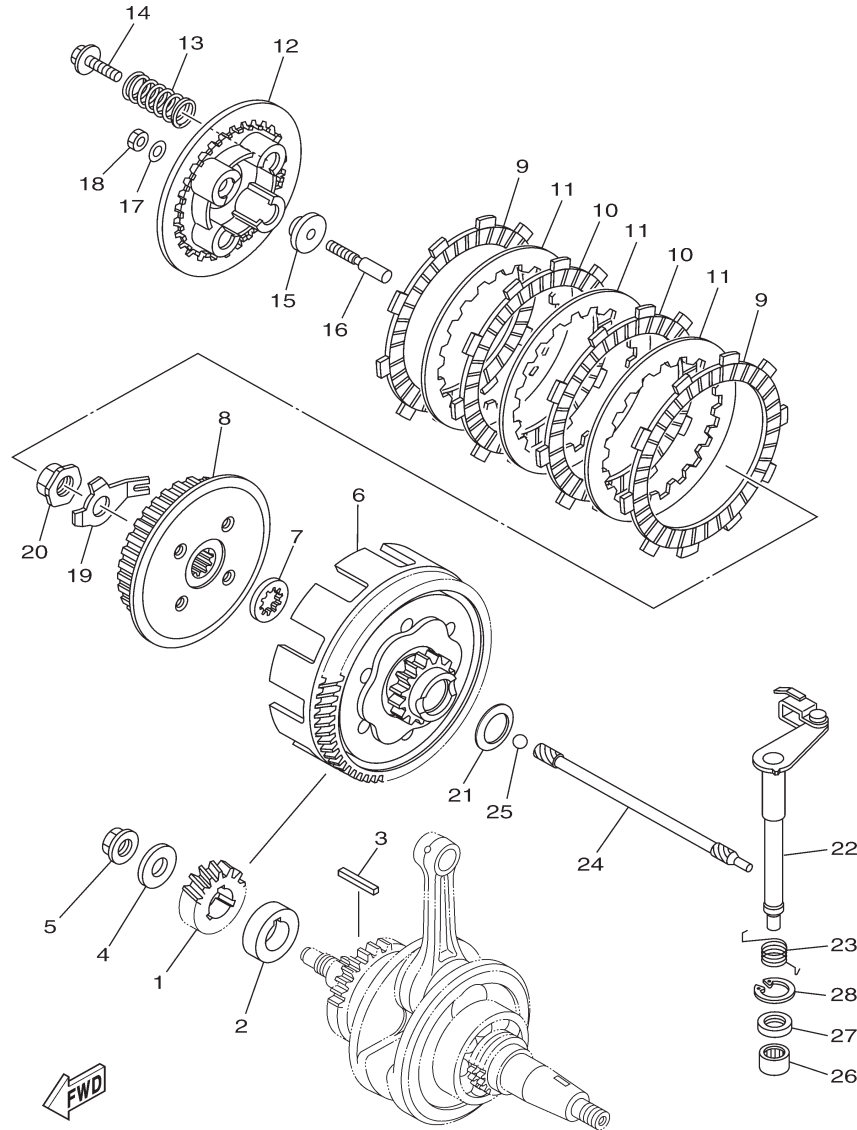

54B1470-J120

REF. NO.	PART NO.	PART NAME	21CE				REMARKS
1	54B-E6111-00	GEAR, PRIMARY DRIVE	1				
2	54B-E7258-00	COLLAR 1	1				
3	21C-E6193-00	KEY, FEATHER	1				
4	90201-12019	WASHER, PLATE	1				
5	90179-12802	NUT	1				
6	54B-E6150-00	PRIMARY DRIVEN GEAR COMP.	1				
7	21C-E6154-00	PLATE, THRUST 1	1				
8	21C-E6371-00	BOSS, CLUTCH	1				
9	54B-E6321-00	PLATE, FRICTION	2				
10	21C-E6331-00	PLATE, FRICTION 2	2				
11	21C-E6324-00	PLATE, CLUTCH 1	3				
12	54B-E6351-00	PLATE, PRESSURE 1	1				
13	21C-E6333-00	SPRING, CLUTCH 1	4				
14	21C-E6337-00	SCREW, SPRING	4				
15	21C-E6358-00	PLATE, PUSH	1				
16	21C-E6356-01	ROD, PUSH 1	1				
17	54B-E6144-00	WASHER	1				
18	3C1-E6344-00	NUT, ADJUSTING	1				
19	21C-E6135-10	WASHER, LOCK	1				
20	90179-14001	NUT	1				
21	90208-20003	WASHER, CONICAL SPRING	1				
22	21C-E6380-01	PUSH LEVER ASSY	1				
23	21C-16345-10	SPRING, RETURN	1				
24	54B-E6357-00	ROD, PUSH 2	1				
25	93505-16844	BALL	1				
26	93315-112Y9	BEARING	1				
27	93102-12877	OIL SEAL	1				
28	99009-20500	CIRCLIP	1				

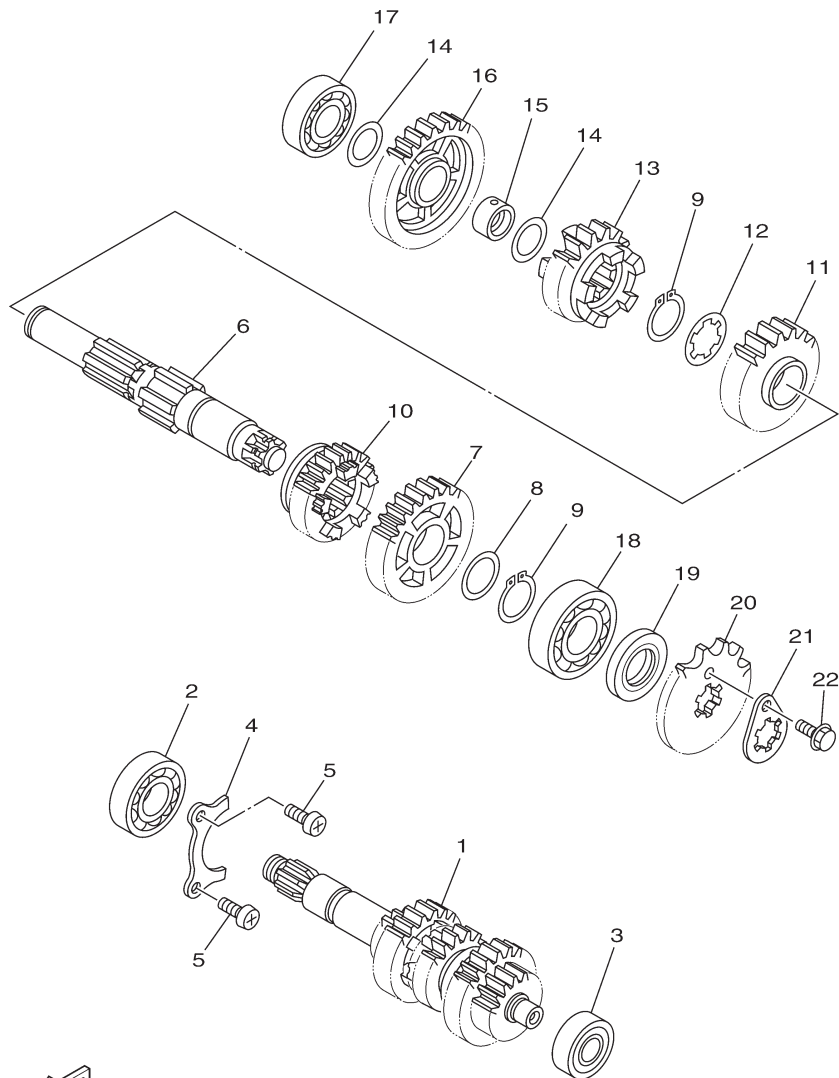

21CB470-L140

FIG. 14 (2Z0) TRANSMISSION

REF. NO.	PART NO.	PART NAME	21CE				REMARKS
1	21C-E7410-40	MAIN AXLE COMP.	1				
2	93306-054YE	BEARING	1				UR
	93306-054Y6	BEARING	1				UR
3	93306-201Y4	BEARING	1				
4	21C-E7471-00	PLATE, COVER	1				
5	98517-06012	SCREW, PAN HEAD	2				
6	21C-E7402-40	DRIVE AXLE ASSY	1				
7	21C-E7221-20	GEAR, 2ND WHEEL (34T)	1				
8	90201-22793	WASHER, PLATE	1				
9	93410-22039	CIRCLIP	2				
10	21C-E7251-40	GEAR, 5TH WHEEL (21T)	1				
11	21C-E7231-30	GEAR, 3RD WHEEL (29T)	1				
12	90209-18208	WASHER	1				
13	21C-E7241-40	GEAR, 4TH WHEEL (23T)	1				
14	90201-177G4	WASHER, PLATE	2				
15	21C-E7258-00	COLLAR 1	1				
16	21C-E7211-20	GEAR, 1ST WHEEL (38T)	1				
17	93306-203XR	BEARING	1				
18	93306-272X4	BEARING	1				UR
	93306-272X1	BEARING	1				UR
19	93102-22818	OIL SEAL	1				
20	93822-14800	SPROCKET, DRIVE (14T)	1				
21	4LS-E7456-00	HOLDER, SPROCKET	1				
22	95027-06010	BOLT, FLANGE	1				

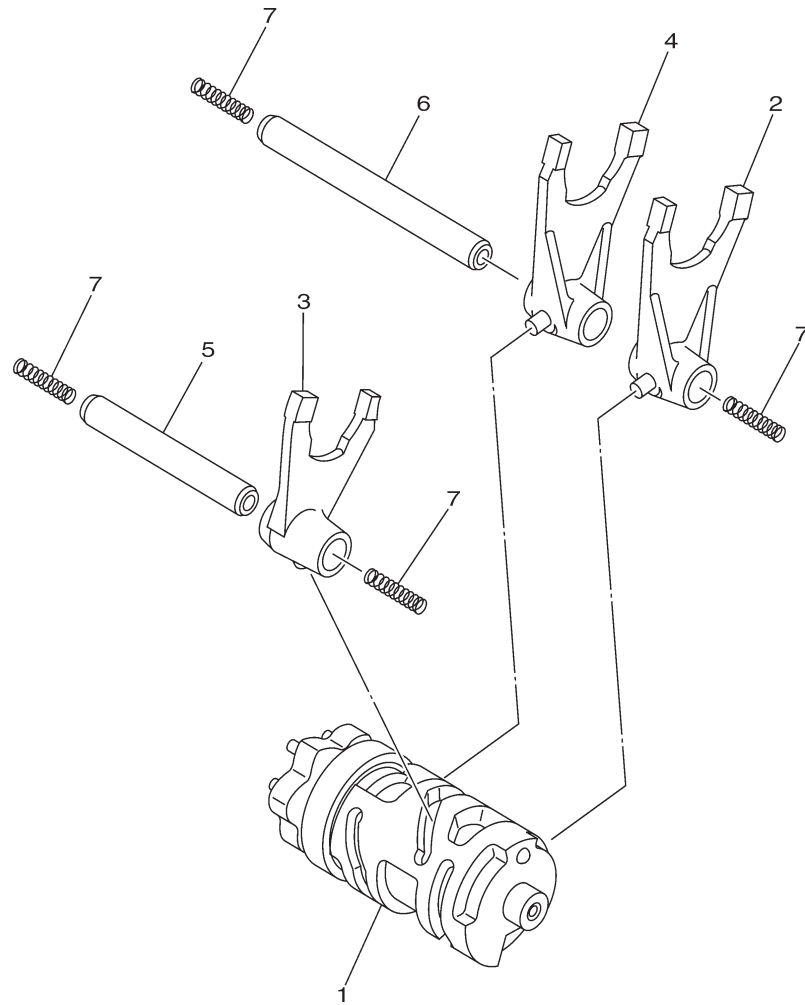

FIG. 15 (3J0) SHIFT CAM & FORK

REF. NO.	PART NO.	PART NAME	21CE				REMARKS
1	21C-E8540-30	SHIFT CAM ASSY	1				
2	1PM-E8511-00	FORK, SHIFT 1	1				
3	1PM-E8512-00	FORK, SHIFT 2	1				
4	1PM-E8513-00	FORK, SHIFT 3	1				
5	21C-E8531-00	BAR, SHIFT FORK GUIDE 1	1				
6	21C-E8535-00	BAR, SHIFT FORK GUIDE 2	1				
7	90501-06800	SPRING, COMPRESSION	4				



21C1470-G140

FIG. 16 (3K0) SHIFT SHAFT

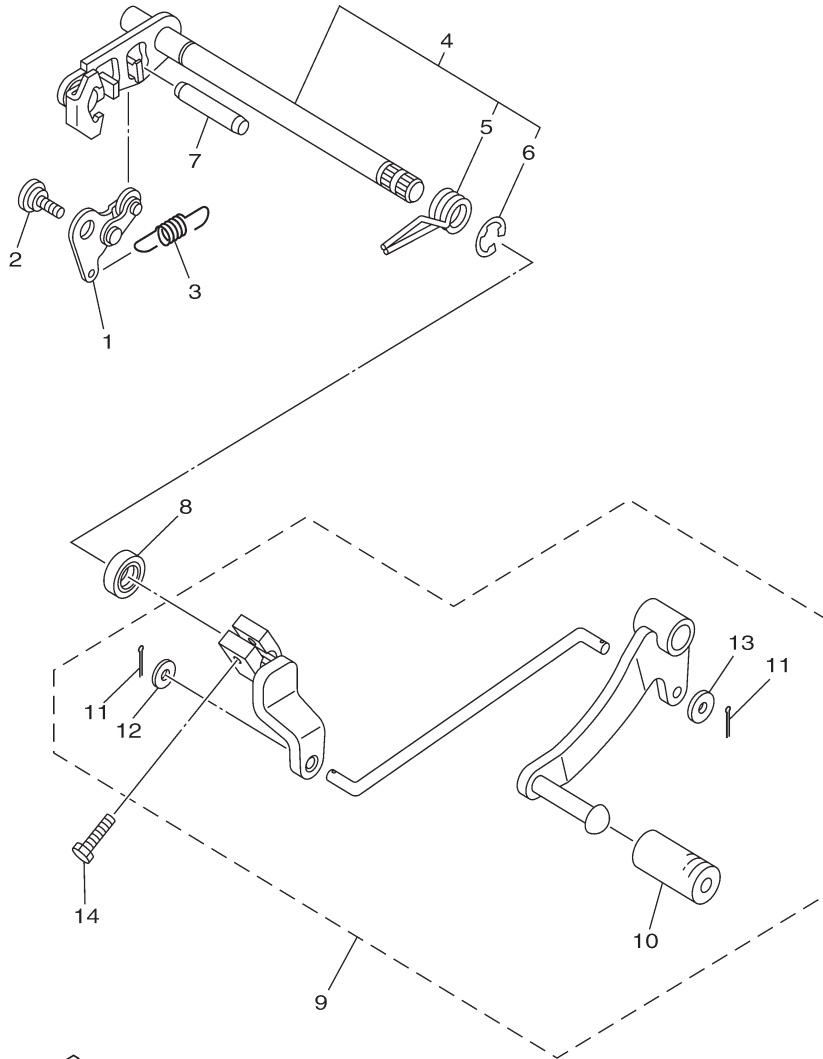

21C1470-G152

REF. NO.	PART NO.	PART NAME	21CE				REMARKS
1	21C-E8140-00	STOPPER LEVER ASSY	1				
2	90109-06259	BOLT	1				
3	21C-E8337-00	SPRING	1				
4	21C-E8101-01	SHIFT SHAFT ASSY	1				
5	90508-32805	.SPRING, TORSION	1				
6	99001-10600	.CIRCLIP	1				
7	93608-43238	PIN, DOWEL	1				
8	93102-12875	OIL SEAL	1				
9	21C-E8110-10	SHIFT PEDAL ASSY	1				
10	20P-E8113-00	.COVER, SHIFT PEDAL	1				
11	91401-20012	.PIN, COTTER	2				
12	92902-06200	.WASHER	1				
13	90201-06871	.WASHER, PLATE	1				
14	97012-06020	BOLT	1				

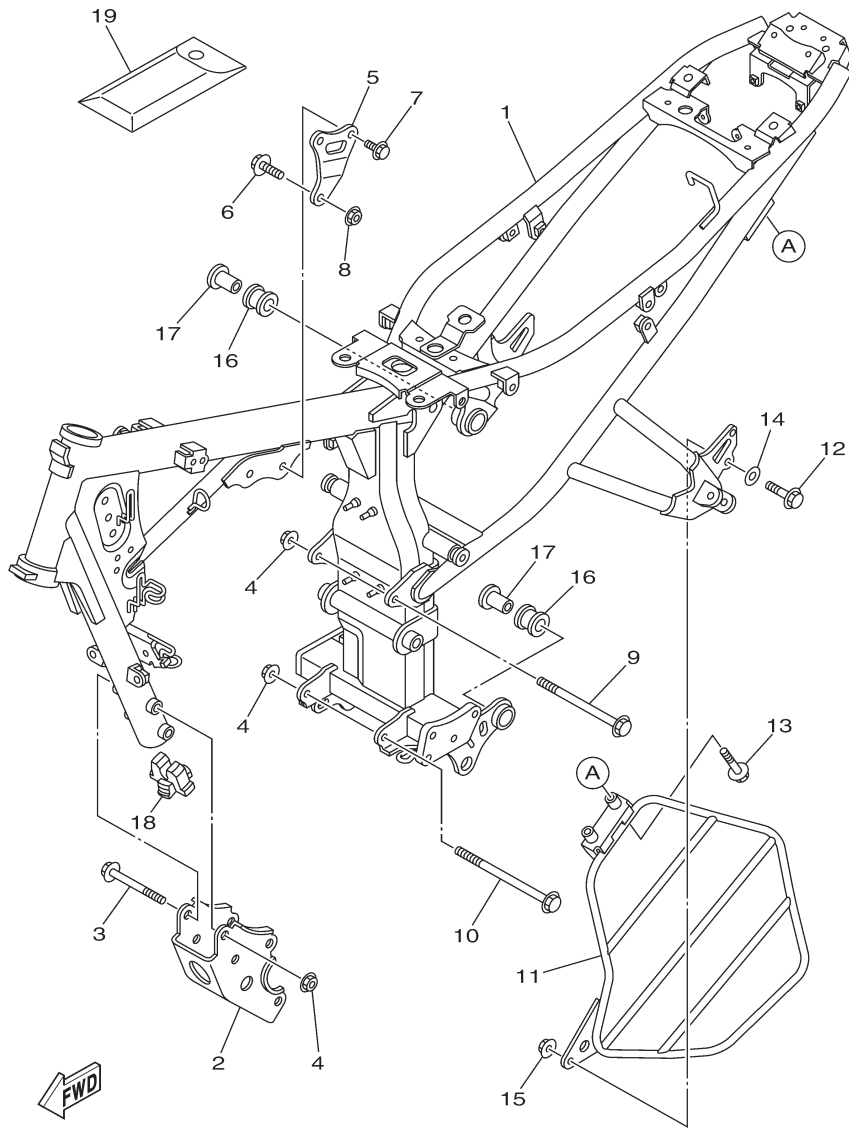

21CD470-L170

FIG. 17 (3M0) FRAME

REF. NO.	PART NO.	PART NAME	21CE				REMARKS
1	21C-F1110-20	FRAME COMP.	1				
2	21C-F1316-00	STAY, ENGINE 3	1				
3	95812-10080	BOLT, FLANGE	4				
4	90179-10658	NUT	6				
5	21C-F1317-00	STAY, ENGINE 3	1				
6	95812-08035	BOLT, FLANGE	1				
7	95812-08016	BOLT, FLANGE	2				
8	90179-08674	NUT	1				
9	95817-10130	BOLT, FLANGE	1				
10	90105-10174	BOLT, FLANGE	1				
11	21C-F1298-10	PROTECTOR, FOOT REST	1				
12	95807-06016	BOLT, FLANGE	1				
13	95802-06025	BOLT, FLANGE	2				
14	90201-061A5	WASHER, PLATE	1				
15	95702-06500	NUT, FLANGE	1				
16	20P-E4747-00	DAMPER, MUFFLER	2				
17	90387-08822	COLLAR	2				
18	21C-F1638-01	DAMPER 1	1				
19	21C-F8100-20	TOOL KIT	1				

FIG. 18 (3Q0) FENDER

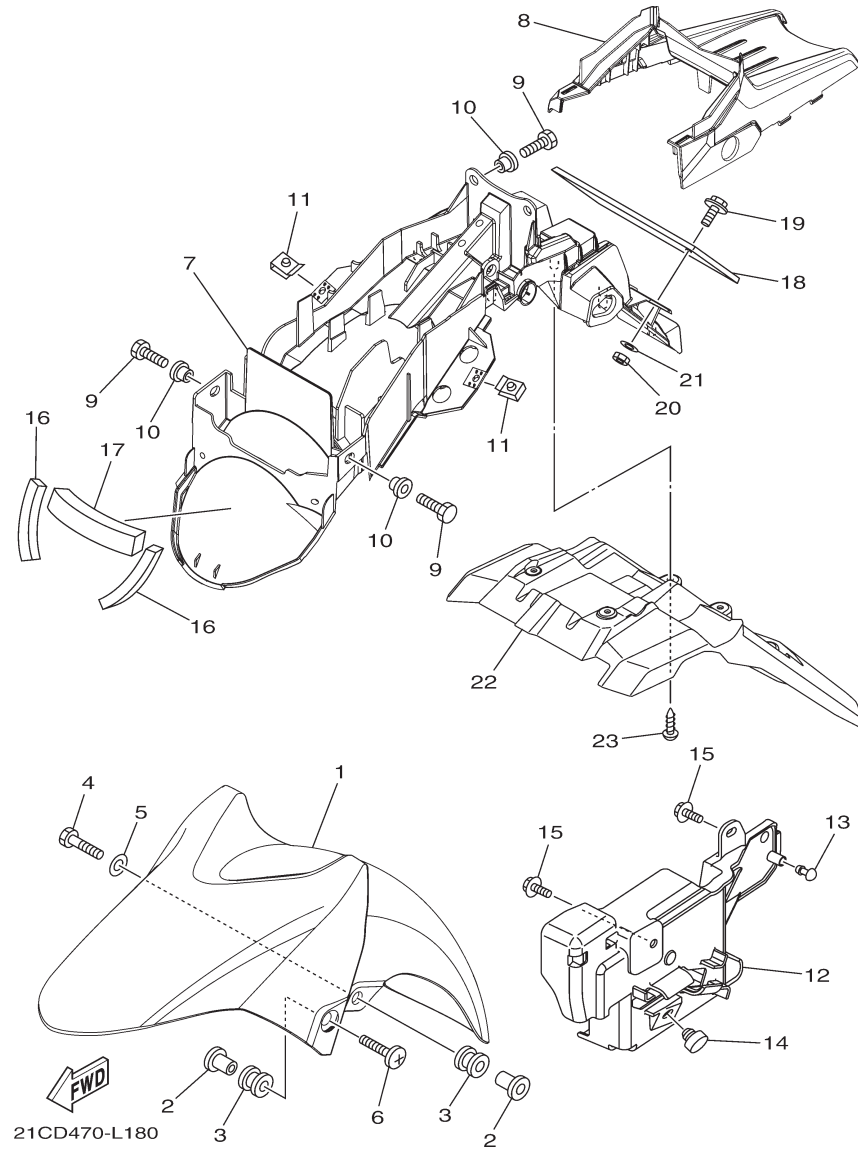

REF. NO.	PART NO.	PART NAME	21CE				REMARKS
1	21C-F1511-00-2X	FENDER, FRONT -YRC2	1				YRC2 FOR YB
	21C-F1511-00-8X	FENDER, FRONT -BWC1	1				FOR VRC1, BWC1
	21C-F1511-00-7X	FENDER, FRONT -LGM6	1				LGM6 FOR YB
2	90387-068C5	COLLAR	4				
3	90480-08801	GROMMET	4				
4	97022-06020	BOLT	2				
5	90201-06726	WASHER, PLATE	2				
6	90154-06061	SCREW, BINDING	2				
7	21C-F1611-01	FENDER, REAR	1				
8	21C-F1651-00	COVER, REAR FENDER	1				
9	97012-06014	BOLT	4				
10	90387-06048	COLLAR	4				
11	90183-05818	NUT, SPRING	2				
12	21C-F177G-10	BOX, BATTERY	1				
13	21C-F1717-00	DAMPER	1				
14	4LS-F4741-00	PAD, SEAT	1				
15	90119-06117	BOLT, WITH WASHER	2				
16	21C-F1669-00	SEAL	2				
17	21C-F16A2-00	SEAL, 2	1				
18	21C-F1681-00	PLATE, LICENSE	1				
19	90159-06021	SCREW, WITH WASHER	2				
20	95307-06600	NUT	2				
21	90201-06078	WASHER, PLATE	2				
22	21C-F1621-00	FLAP	1				
23	97702-50014	SCREW, TAPPING	6				

FIG. 19 (3U0) SIDE COVER

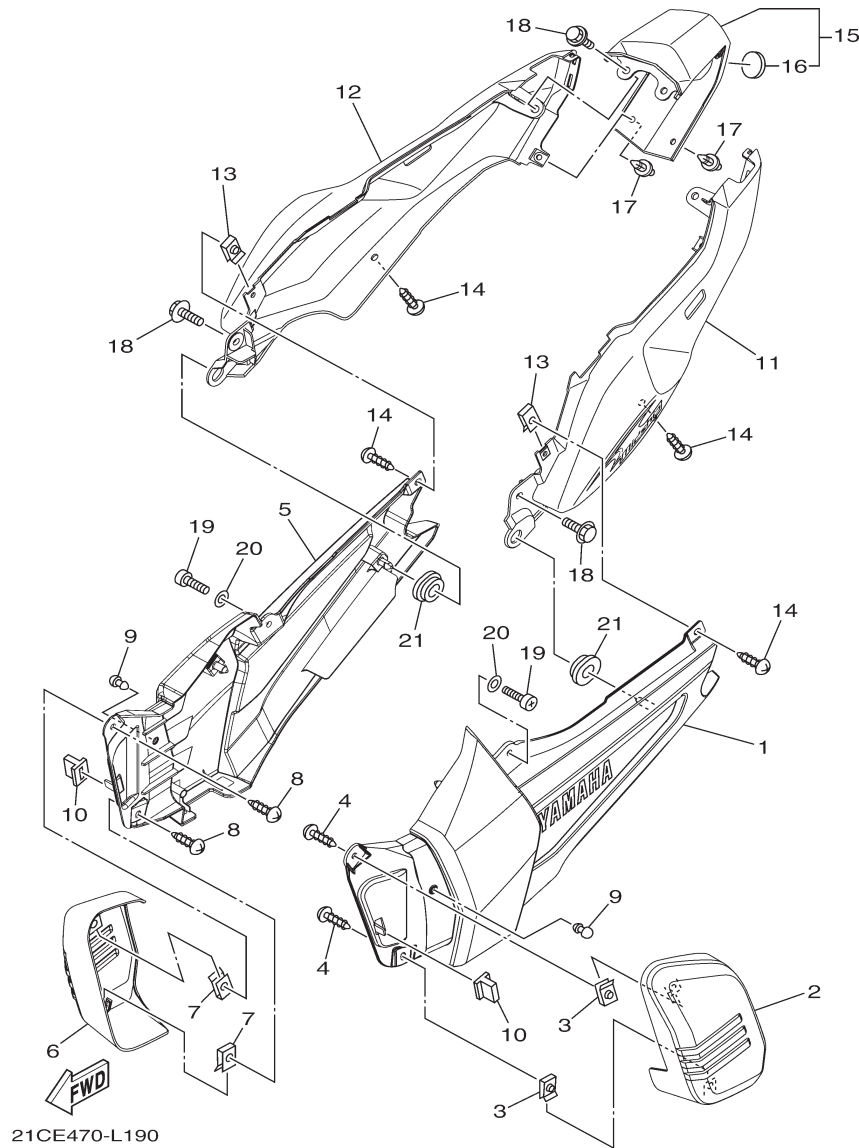

21CE470-L190

REF. NO.	PART NO.	PART NAME	21CE			REMARKS
1	45S-XF171-20-P1	COVER, SIDE 1 -MBL2	1			MBL2
2	21C-F172A-10	PANEL 1	1			
3	90183-05818	NUT, SPRING	2			
4	97702-50012	SCREW, TAPPING	2			
5	45S-XF172-20-P1	COVER, SIDE 2 -MBL2	1			MBL2
6	21C-F172F-10	PANEL 2	1			
7	90183-05818	NUT, SPRING	2			
8	97702-50012	SCREW, TAPPING	2			
9	21C-F1717-00	DAMPER	2			
10	5DG-F1778-00	DAMPER, LOCATING 1	2			
11	21C-XF173-L0-33	COVER, SIDE 3 -YB	1			UR FOR YB
	21C-XF173-M0-P1	COVER, SIDE 3 -VRC1	1			UR FOR VRC1
	21C-XF173-N0-P2	COVER, SIDE 3 -BWC1	1			UR FOR BWC1
	21C-XF173-P0-33	COVER, SIDE 3 -YB	1			UR FOR YB
12	21C-XF174-L0-33	COVER, SIDE 4 -YB	1			UR FOR YB
	21C-XF174-M0-P1	COVER, SIDE 4 -VRC1	1			UR FOR VRC1
	21C-XF174-N0-P2	COVER, SIDE 4 -BWC1	1			UR FOR BWC1
	21C-XF174-P0-33	COVER, SIDE 4 -YB	1			UR FOR YB
13	90183-05818	NUT, SPRING	2			
14	97702-50012	SCREW, TAPPING	4			
15	21C-XF17C-F0-P1	COVER, SIDE 5 -YRC2	1			UR YRC2 FOR YB
	21C-XF17C-G0-P2	COVER, SIDE 5 -BWC1	1			UR BWC1 FOR VRC1
	21C-XF17C-H0-P3	COVER, SIDE 5 -BMC1	1			UR BMC FOR BWC1
	21C-XF17C-J0-P3	COVER, SIDE 5 -YB	1			UR LGM6 FOR YB
16	5TS-F836B-02	.TUNING FORK MARK	1			
17	90269-06008	RIVET	2			
18	90119-06137	BOLT, WITH WASHER	4			
19	98502-06016	SCREW, PAN HEAD	2			
20	90201-06055	WASHER, PLATE	2			
21	90480-01559	GROMMET	2			

FIG. 20 (4A0) REAR ARM & SUSPENSION

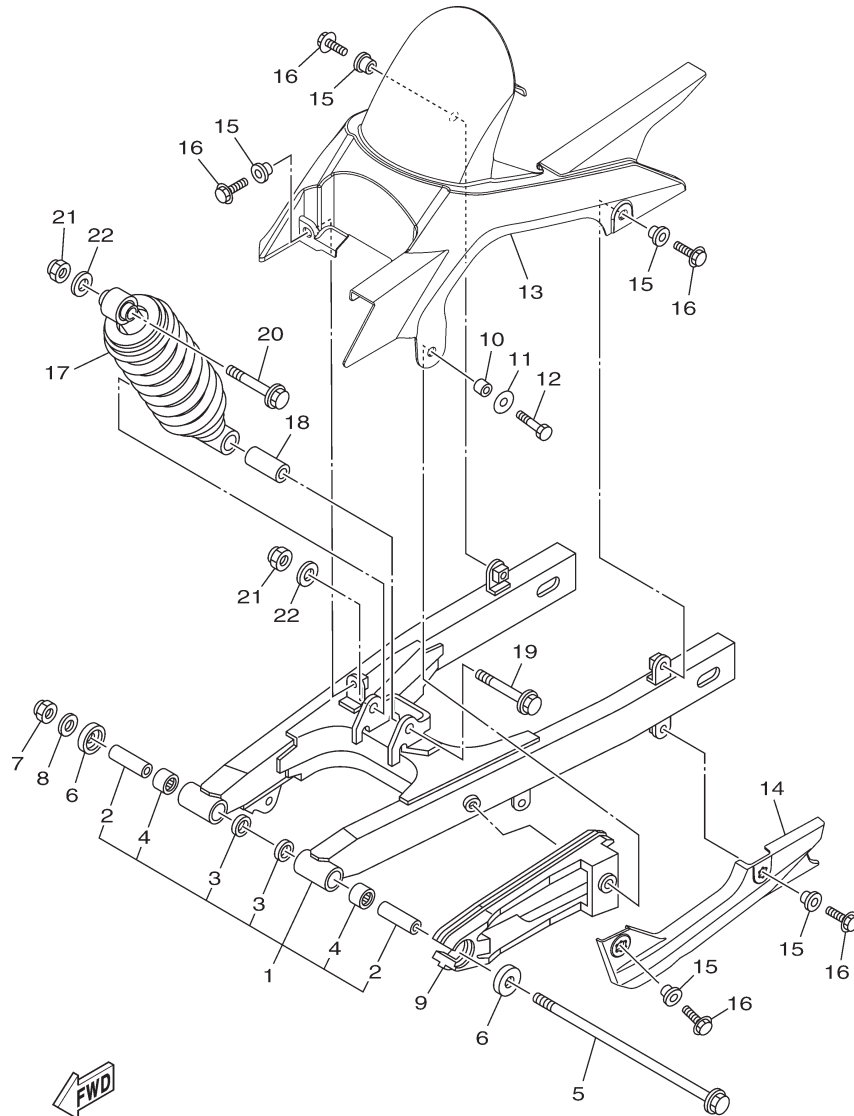

21CD470-L200

REF. NO.	PART NO.	PART NAME	21CE				REMARKS
1	21C-WF211-10	REARARM COMP.	1				
2	21C-F2184-00	.BUSH	2				
3	93109-18803	.OIL SEAL	2				
4	93317-318Y5	.BEARING	2				
5	21C-F2141-00	SHAFT, PIVOT	1				
6	20P-F2129-00	COVER, THRUST 2	2				
7	95612-12100	NUT, U	1				
8	90201-12030	WASHER, PLATE	1				
9	21C-F2151-00	SEAL, GUARD	1				
10	90387-066J9	COLLAR	1				
11	90201-060A3	WASHER, PLATE	1				
12	97027-06025	BOLT, HEXAGON	1				
13	21C-F1650-00	REAR FENDER COMP.	1				
14	21C-F2147-00	PROTECTOR, CHAIN	1				
15	90387-068S1	COLLAR	5				
16	95027-06014	BOLT, FLANGE	5				
17	21C-F2210-00	SHOCK ABSORBER ASSY, REAR	1				
18	90387-12845	COLLAR	1				
19	90105-12057	BOLT, FLANGE	1				
20	90105-12085	BOLT, FLANGE	1				
21	95612-12100	NUT, U	2				
22	90201-12030	WASHER, PLATE	2				

FIG. 21 (4H0) STEERING

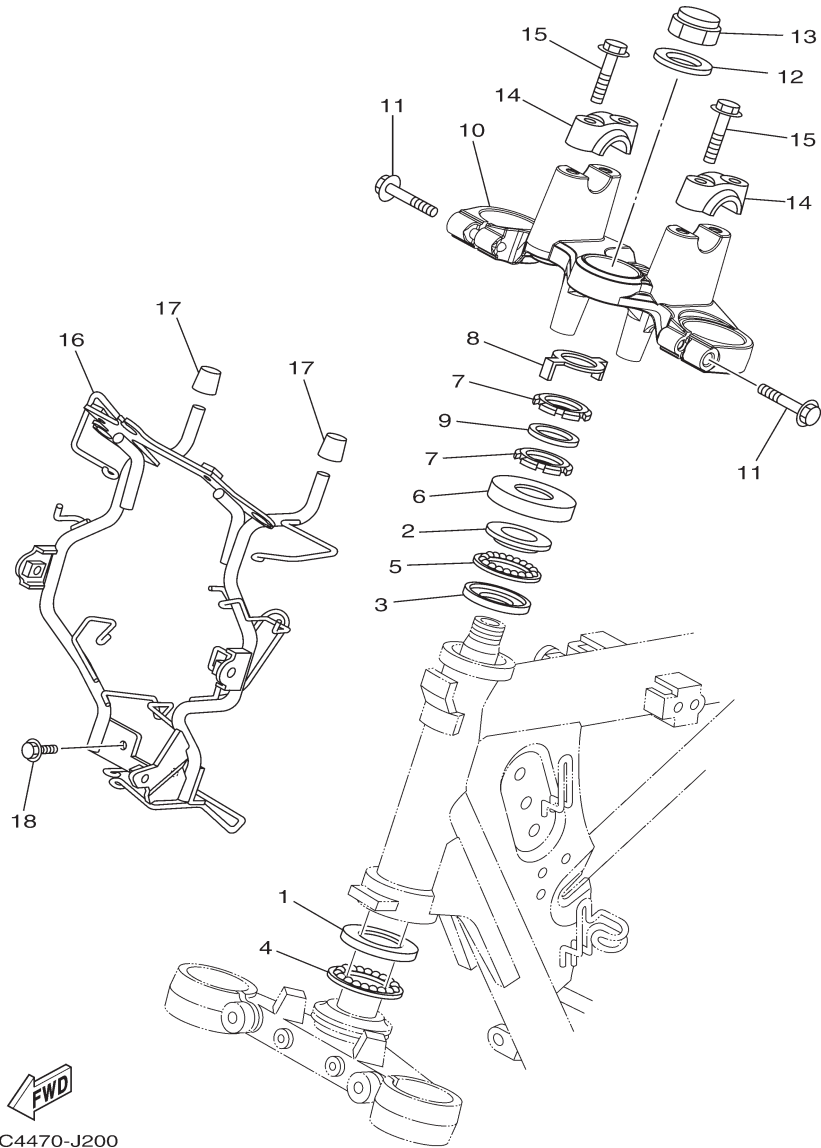

21C4470-J200

REF. NO.	PART NO.	PART NAME	21CE				REMARKS
1	5KA-F3412-00	RACE, BALL 2	1				
2	5KA-F3413-00	RACE, BALL 3	1				
3	5KA-F3414-00	RACE, BALL 4	1				
4	4LS-F341E-10	RETAINER, BALL BEARING	1				
5	4LS-F341E-00	RETAINER, BALL BEARING	1				
6	5YY-F3416-00	COVER, BALL RACE 2	1				
7	90179-25615	NUT	2				
8	20P-F3418-00	WASHER, SPECIAL	1				
9	90202-26142	WASHER, PLATE	1				
10	21C-F3435-00	CROWN, HANDLE	1				
11	95022-08040	BOLT, FLANGE	2				
12	90201-22018	WASHER, PLATE	1				
13	90176-22081	NUT, CROWN	1				
14	21C-F3441-00	HOLDER, HANDLE UPPER	2				
15	95024-08035	BOLT, FLG.(SMALL HEAD)	4				
16	21C-F3174-30	STAY, HEADLIGHT	1				
17	21C-F317J-00	DAMPER 1	2				
18	95807-06014	BOLT, FLANGE	2				

FIG. 22 (4K0) FRONT FORK

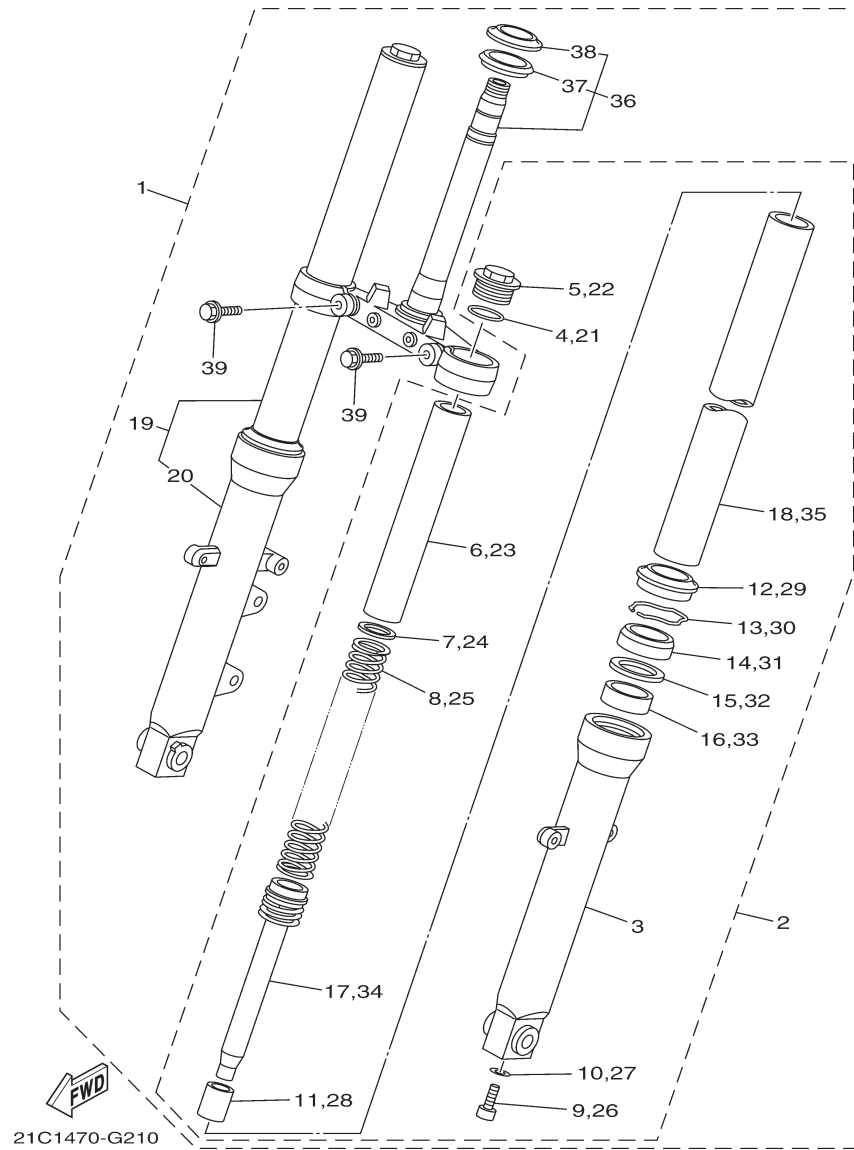

REF. NO.	PART NO.	PART NAME	21CE				REMARKS
1	21C-F3100-11	FRONT FORK ASSY	1				
2	21C-F3102-11	..FRONT FORK ASSY (L.H)	1				
3	21C-F3126-11	..TUBE, OUTER (LEFT)	1				
4	21C-F3114-00	..GASKET	1				
5	21C-F3111-00	..BOLT, CAP	1				
6	21C-F3118-00	..SPACER	1				
7	21C-F3149-00	..WASHER, SPRING UPPER	1				
8	21C-F3141-00	..SPRING, FRONT FORK	1				
9	21C-F3181-00	..BOLT, HEXAGON SOCKET HEAD	1				
10	21C-F3158-00	..GASKET	1				
11	21C-F3173-00	..SPINDLE, TAPER	1				
12	4EB-23144-00	..SEAL, DUST	1				
13	21C-F3156-00	..RING, SNAP	1				
14	4EB-23145-01	..OIL SEAL	1				
15	21C-F3146-00	..WASHER, OIL SEAL	1				
16	4FM-23125-40	..METAL, SLIDE 1	1				
17	21C-F3170-00	..CYLINDER COMP., FRONT FORK	1				
18	21C-F3110-00	..INNER TUBE COMP.1	1				
19	21C-F3103-11	..FRONT FORK ASSY (R.H)	1				
20	21C-F3136-11	..TUBE, OUTER (RIGHT)	1				
21	21C-F3114-00	..GASKET	1				
22	21C-F3111-00	..BOLT, CAP	1				
23	21C-F3118-00	..SPACER	1				
24	21C-F3149-00	..WASHER, SPRING UPPER	1				
25	21C-F3141-00	..SPRING, FRONT FORK	1				
26	21C-F3181-00	..BOLT, HEXAGON SOCKET HEAD	1				
27	21C-F3158-00	..GASKET	1				
28	21C-F3173-00	..SPINDLE, TAPER	1				
29	4EB-23144-00	..SEAL, DUST	1				
30	21C-F3156-00	..RING, SNAP	1				

FIG. 22 (4K0) FRONT FORK

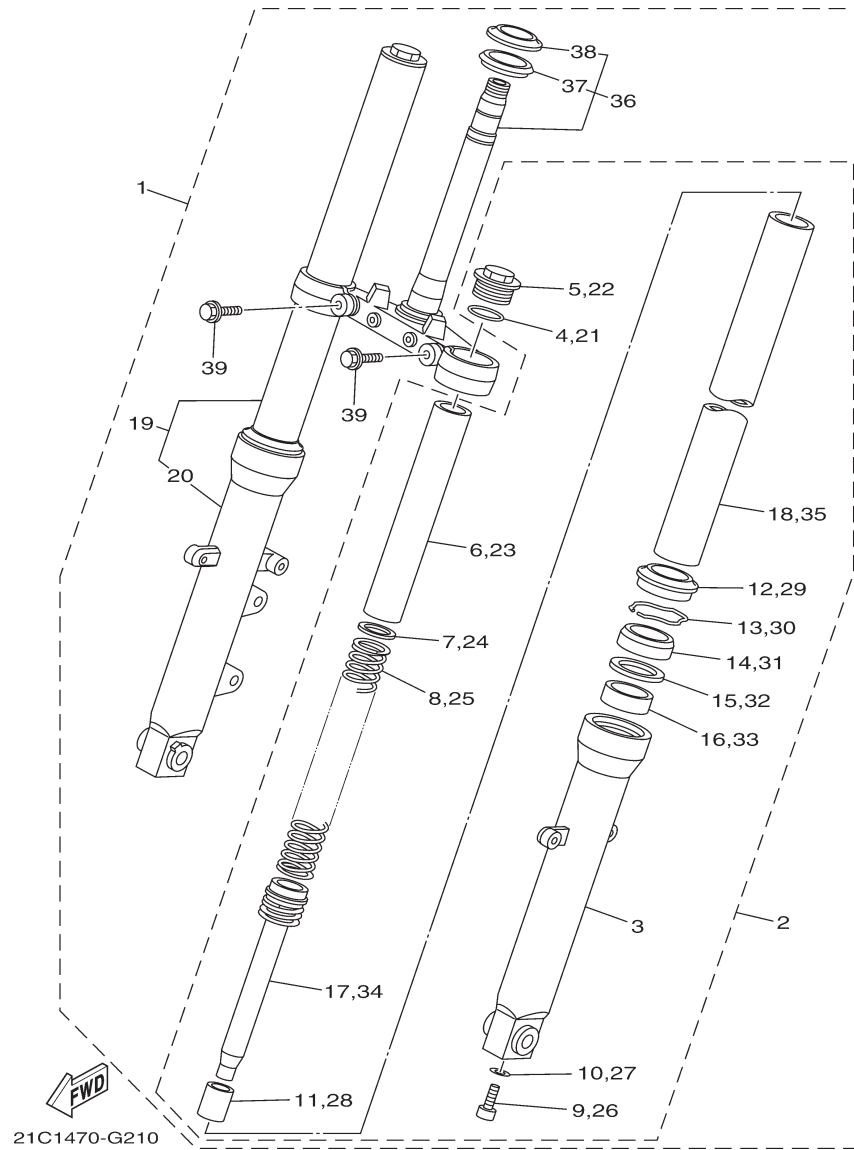

REF. NO.	PART NO.	PART NAME	21CE				REMARKS
31	4EB-23145-01	..OIL SEAL	1				
32	21C-F3146-00	..WASHER, OIL SEAL	1				
33	4FM-23125-40	..METAL, SLIDE 1	1				
34	21C-F3170-00	..CYLINDER COMP., FRONT FORK	1				
35	21C-F3110-00	..INNER TUBE COMP.1	1				
36	21C-F3340-00	..UNDER BRACKET COMP.	1				
37	5YY-F3462-00	..SEAL, DUST	1				
38	5KA-F3411-00	..RACE, BALL 1	1				
39	21C-F3346-00	..BOLT 1	2				

FIG. 23 (4S0) FUEL TANK

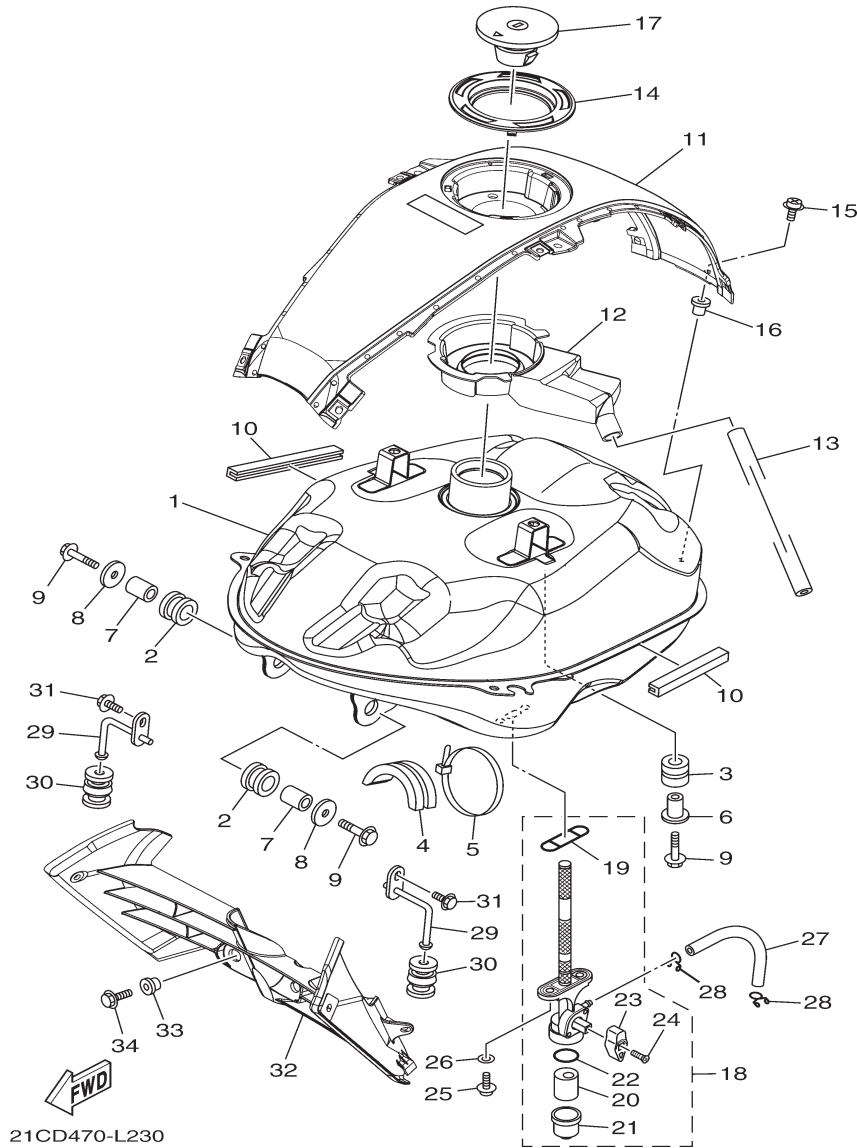

21CD470-L230

REF. NO.	PART NO.	PART NAME	21CE				REMARKS
1	21C-F4110-00	FUEL TANK COMP.	1				
2	21C-F4181-00	DAMPER, LOCATING 1	2				
3	21C-F4182-00	DAMPER, LOCATING 2	2				
4	21C-F4183-00	DAMPER, LOCATING 3	1				
5	90464-80802	CLAMP	1				
6	90387-068M3	COLLAR	2				
7	90387-107H6	COLLAR	2				
8	90201-060A3	WASHER, PLATE	2				
9	95822-06030	BOLT, FLANGE	4				
10	21C-F4188-10	MOLD, FUEL TANK	2				
11	21C-XF17D-E0-P7	COVER, TOP -YRC2	1				UR YRC2 FOR YB
	21C-XF17D-F0-P8	COVER, TOP -BWC1	1				UR BWC1 FOR VRC1
	21C-XF17D-40-P2	COVER, TOP -BMC1	1				UR BMC FOR BWC1
	21C-XF17D-60-P4	COVER, TOP -YB	1				UR LGM6 FOR YB
12	21C-F414A-00	COVER, FILLER	1				
13	21C-F4318-00	PIPE, OVERFLOW	1				
14	21C-F4614-00-P0	PLATE, CAP -SILVER	1				S8
15	90159-05065	SCREW, WITH WASHER	3				
16	90179-05523	NUT	3				
17	21C-WF461-10	CAP ASSY WITH LOCK	1				
18	21C-F4500-10	FUEL COCK ASSY 1	1				
19	54B-F4512-10	.GASKET	1				
20	54B-F4514-10	.NET, FILTER 1	1				
21	54B-F4521-10	.CUP, FILTER	1				
22	54B-F4564-10	.GASKET	1				
23	54B-F4598-10	.KNOB	1				
24	54B-F4535-10	.SCREW, LEVER FITTING	1				
25	90149-06108	SCREW	2				
26	90202-05807	WASHER, PLATE	2				
27	21C-F4311-00	PIPE, FUEL 1	1				
28	90467-100A3	CLIP	2				

FIG. 23 (4S0) FUEL TANK

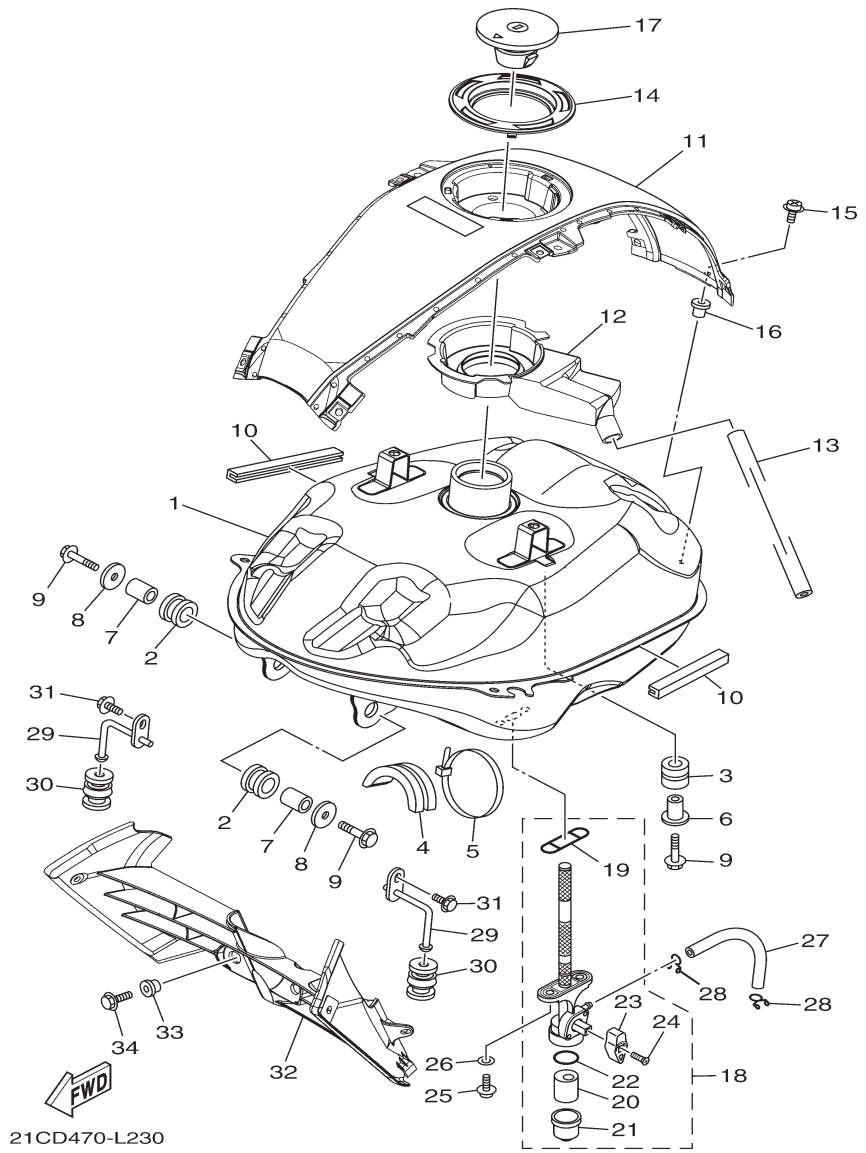

21CD470-L230

REF. NO.	PART NO.	PART NAME	21CE				REMARKS
29	21C-F411G-10	HOOK, SIDE COVER 1	2				
30	21C-F411J-10	DAMPER, SIDE COVER	2				
31	95802-06012	BOLT, FLANGE	2				
32	21C-F4124-10	AIR SHROUD	1				
33	90387-06048	COLLAR	2				
34	95827-06012	BOLT, FLANGE	2				

FIG. 24 (4S1) FUEL TANK 2

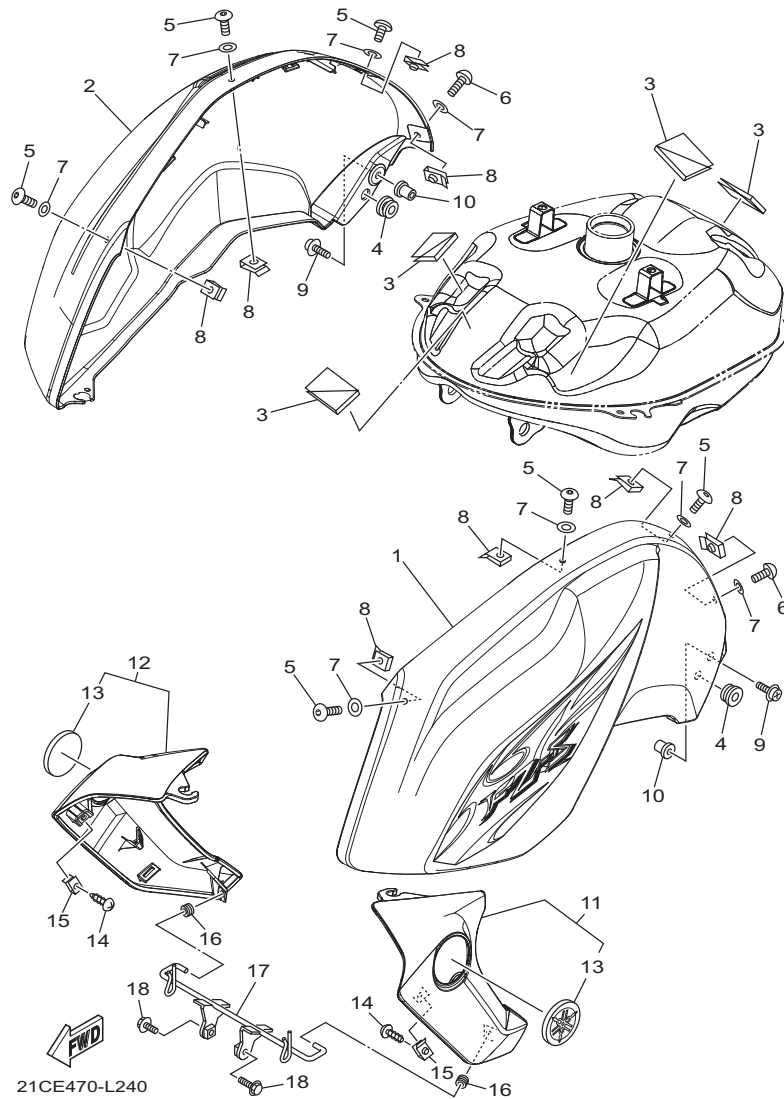

REF. NO.	PART NO.	PART NAME	21CE			REMARKS
1	21C-XF412-T0-33	TANK SIDE COVER 1 -YB	1			UR FOR YB
	21C-XF412-U0-P5	TANK SIDE COVER 1 -VRC1	1			UR FOR VRC1
	21C-XF412-V0-P4	TANK SIDE COVER 1 -BWC1	1			UR FOR BWC1
	21C-XF412-0A-33	TANK SIDE COVER 1 -YB	1			UR FOR YB
2	21C-XF413-T0-33	TANK SIDE COVER 2 -YB	1			UR FOR YB
	21C-XF413-U0-P5	TANK SIDE COVER 2 -VRC1	1			UR FOR VRC1
	21C-XF413-V0-P4	TANK SIDE COVER 2 -BWC1	1			UR FOR BWC1
	21C-XF413-0A-33	TANK SIDE COVER 2 -YB	1			UR FOR YB
3	21C-F414H-10	DAMPER, PLATE 1	4			
4	90480-13398	GROMMET	2			
5	90111-05003	BOLT,HEX. SOCKET BUTTON	6			
6	90111-05002	BOLT,HEX. SOCKET BUTTON	2			
7	90202-05180	WASHER, PLATE	8			
8	90183-05061	NUT, SPRING	8			
9	90159-05065	SCREW, WITH WASHER	2			
10	90179-05523	NUT	2			
11	21C-XF137-C0-P4	SCOOP & GUIDE AIR 1 -YRC2	1			UR YRC2 FOR YB
	21C-XF137-D0-P5	SCOOP & GUIDE AIR 1 -BWC1	1			UR FOR VRC1, BWC1
	21C-XF137-B0-P3	SCOOP & GUIDE AIR 1 -LGM6	1			UR LGM6 FOR YB
12	21C-XF13A-C0-P4	SCOOP & GUIDE AIR 2 -YRC2	1			UR YRC2 FOR YB
	21C-XF13A-D0-P5	SCOOP & GUIDE AIR 2 -BWC1	1			UR FOR VRC1, BWC1
	21C-XF13A-B0-P3	SCOOP & GUIDE AIR 2 -YB	1			UR LGM6 FOR YB
13	5TS-F413B-00	.EMBLEM	1			
14	97702-50012	SCREW, TAPPING	4			
15	90183-05818	NUT, SPRING	4			
16	90480-12816	GROMMET	2			
17	21C-F4216-10	STAY	1			
18	95802-06012	BOLT, FLANGE	2			

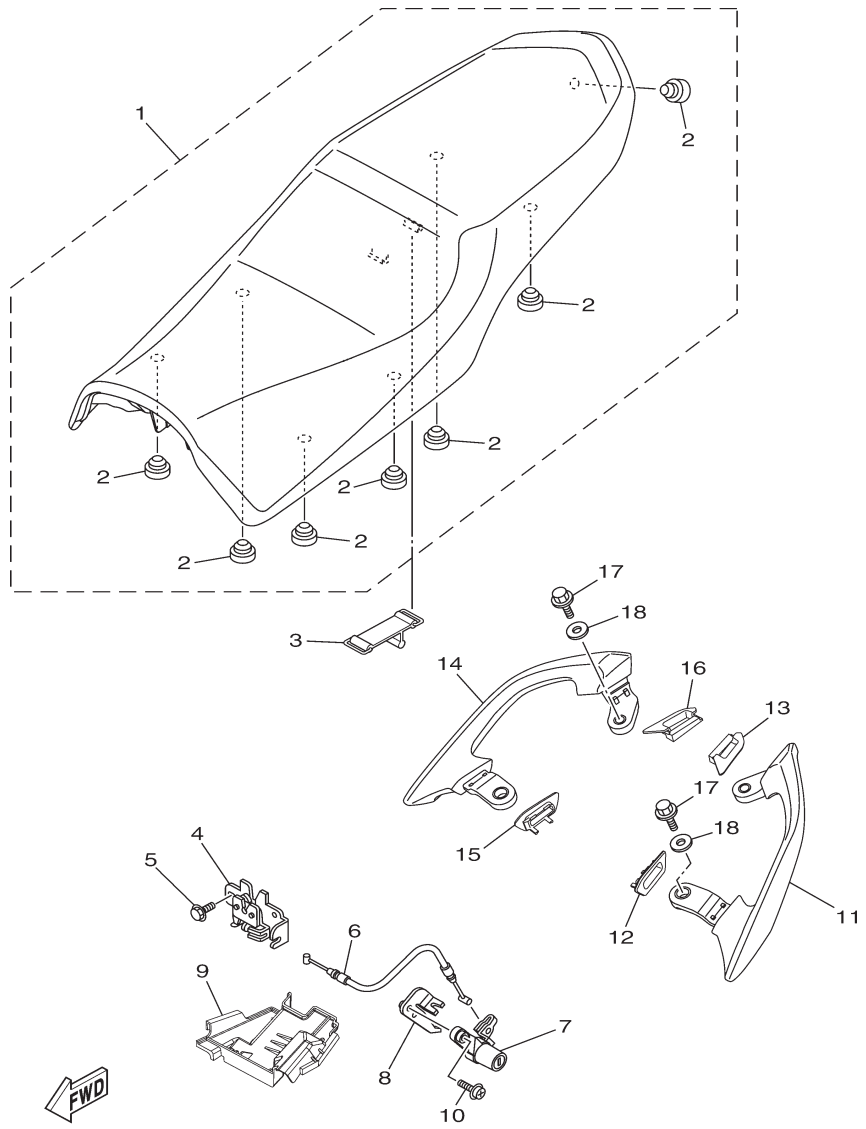

21CD470-L250

FIG. 25 (4U0) SEAT

REF. NO.	PART NO.	PART NAME	21CE				REMARKS
1	21C-F4730-20	DOUBLE SEAT ASSY	1				
2	20P-F4741-00	.PAD, SEAT	7				
3	4UU-F811G-00	BAND	1				
4	21C-F4780-01	SEAT LOCK ASSY	1				
5	95022-06010	BOLT, FLANGE	2				
6	21C-F478E-01	CABLE, SEAT LOCK	1				
7	21C-WF479-00	ROTOR SUB ASSY WITH KEY	1				
8	21C-F117K-00	STAY, LOCK	1				
9	21C-F472T-10	COVER, SEAT LOCK	1				
10	90159-06054	SCREW, WITH WASHER	1				
11	21C-F470J-00-P0	ASSIST GRIP ASSY., 1 -DBNM8	1				DBNM8
12	21C-F281A-00	SEAL, RUBBER 1	1				
13	21C-F281F-00	SEAL, RUBBER 3	1				
14	21C-F470K-00-P0	ASSIST GRIP ASSY., 2 -DBNM8	1				DBNM8
15	21C-F281E-00	SEAL, RUBBER 2	1				
16	21C-F281G-00	SEAL, RUBBER 4	1				
17	95022-08025	BOLT, FLANGE	4				
18	90201-08871	WASHER, PLATE	4				

FIG. 26 (4W0) FRONT WHEEL

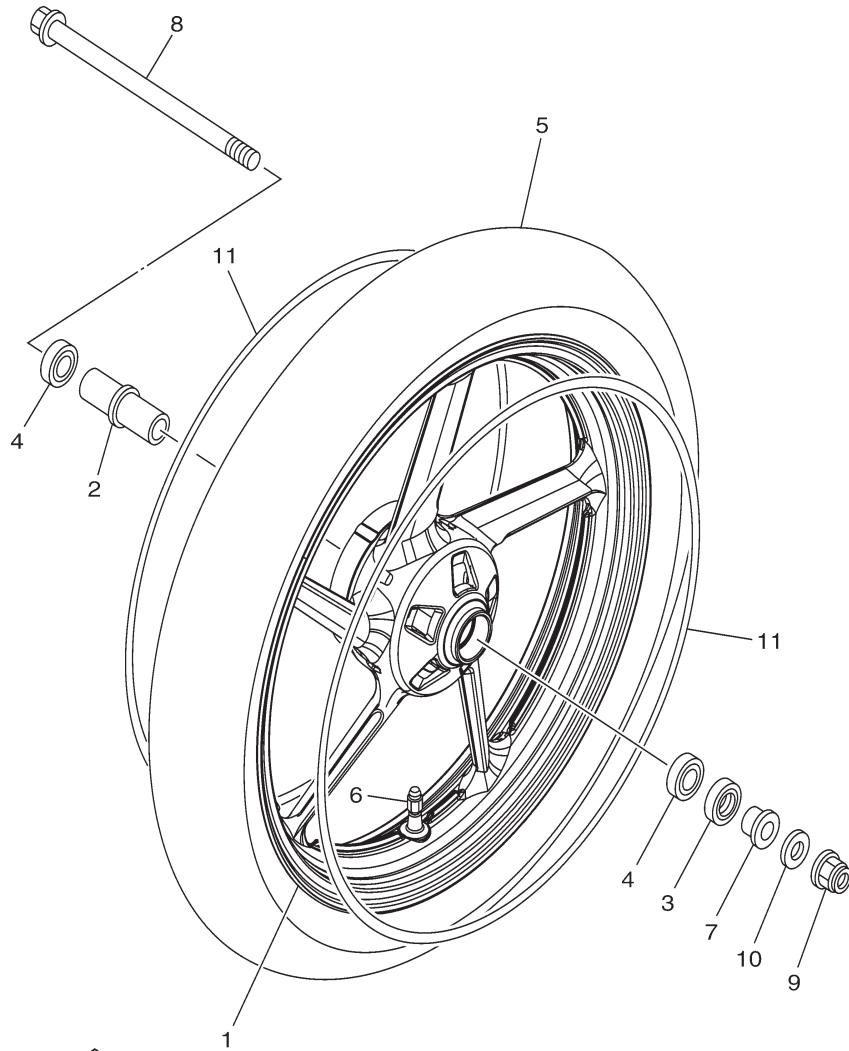

21CE470-L260

REF. NO.	PART NO.	PART NAME	21CE				REMARKS
1	21C-F5168-20-33	CAST WHEEL, FRONT	1				YB
2	21C-F510C-10	COLLAR ASSY.	1				
3	93106-22808	OIL SEAL	1				
4	93306-252XG	BEARING	2				UR
	93306-252YH	BEARING	2				UR
5	94110-17804	TIRE (100/80-17 MC 52P)	1				MRF
6	93900-00824	VALVE, RIM	1				
7	21C-F5183-01	COLLAR, WHEEL	1				
8	21C-F5181-00	AXLE, WHEEL	1				
9	95602-14200	NUT, SELF-LOCKING	1				
10	92902-14200	WASHER	1				
11	21C-F531B-31	EMBLEM, WHEEL	2				UR FOR YB
	21C-F531B-50	EMBLEM, WHEEL	2				UR FOR YB
	21C-F531B-60	EMBLEM, WHEEL	2				UR FOR BWC1
	1CK-F531B-00	EMBLEM, WHEEL	2				UR FOR VRC1

FIG. 27 (4X0) FRONT BRAKE CALIPER

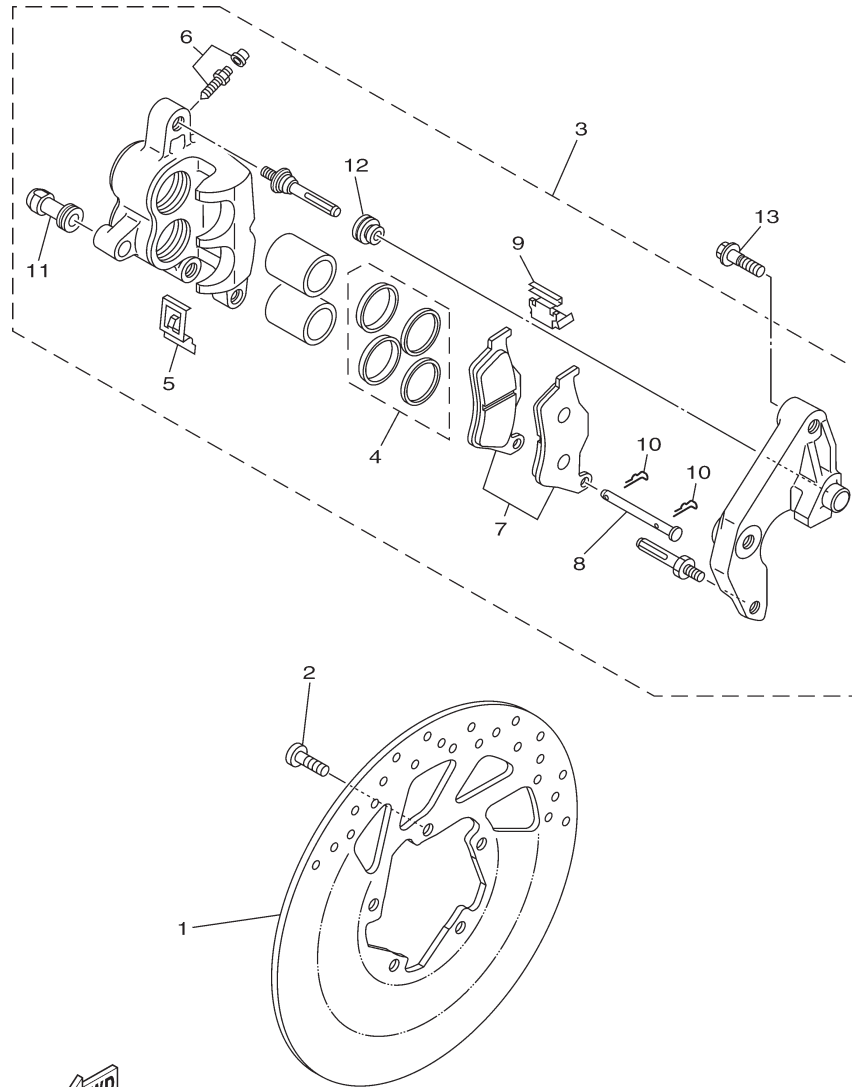

21C1470-G260

REF. NO.	PART NO.	PART NAME	21CE					REMARKS
1	21C-F582U-00	DISK, BRAKE (RIGHT)	1					
2	90111-08847	BOLT,HEX. SOCKET BUTTON	5					
3	5YY-F580U-20	CALIPER ASSY (RIGHT)	1					
4	5US-W0047-00	.CALIPER SEAL KIT	1					
5	5US-F5977-00	.SPRING, RETURN	1					
6	5US-W0048-00	.BLEED SCREW KIT	1					
7	5US-W0045-00	.BRAKE PAD KIT	1					
8	5US-F5744-00	.PIN 2	1					
9	5US-F5827-00	.SHIM, CALIPER	1					
10	5US-W0016-00	.CLIP	1					
11	5US-W0068-00	.INSULATOR	1					
12	5US-W0053-00	.DUST COVER	1					
13	90105-10319	BOLT, FLANGE	2					

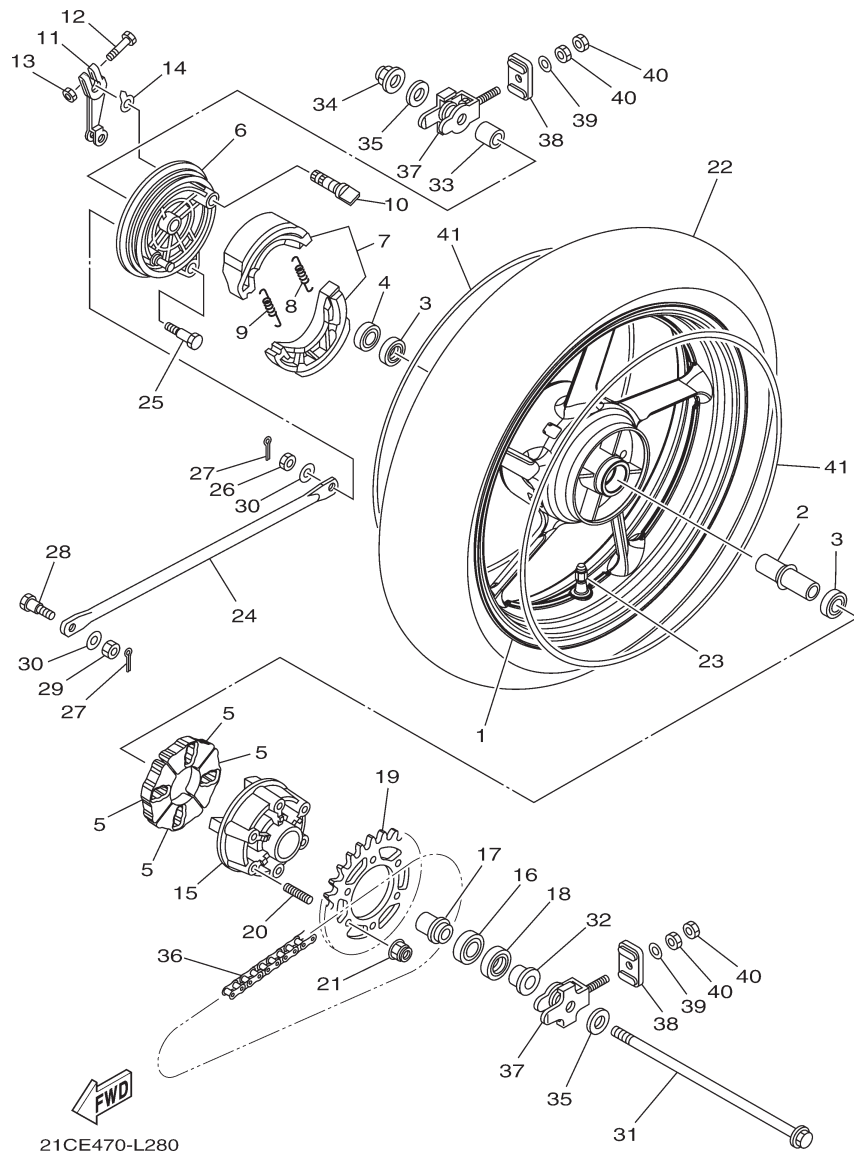

FIG 28 (4Y0) REAR WHEEL

REF. NO.	PART NO.	PART NAME	21CE				REMARKS
1	21C-F5338-20-33	CAST WHEEL, REAR	1				YB
2	21C-F530S-10	COLLAR ASSY	1				
3	93306-252XG	BEARING	2				UR
	93306-252YH	BEARING	2				UR
4	93106-22808	OIL SEAL	1				
5	21C-F5364-00	DAMPER	4				
6	5US-F5321-10	PLATE, BRAKE SHOE	1				
7	5YY-WF533-00	BRAKE SHOE KIT	1				
8	90506-12001	SPRING, TENSION	1				
9	90506-15001	SPRING, TENSION	1				
10	5YY-F5351-00	CAMSHAFT	1				
11	21C-F5355-01	LEVER, CAMSHAFT	1				
12	90101-06046	BOLT	1				
13	95307-06600	NUT	1				
14	36L-F533A-00	PLATE, INDICATOR	1				
15	20P-F5366-00-33	CLUTCH, HUB	1				YB
16	93306-054YA	BEARING	1				UR
	93306-054Y5	BEARING	1				UR
17	20P-F5377-00	COLLAR, WHEEL	1				
18	93106-26801	OIL SEAL	1				
19	21C-F5440-00	SPROCKET, DRIVEN (40T)	1				
20	90116-08834	BOLT, STUD	6				
21	95602-08200	NUT, SELF-LOCKING	6				
22	94114-17800	TIRE (140/60-17 MC 63P)	1				MRF
23	93900-00824	VALVE, RIM	1				
24	21C-F5371-00	BAR, TENSION	1				
25	90109-08063	BOLT	1				
26	95302-08700	NUT	1				
27	91401-20012	PIN, COTTER	2				

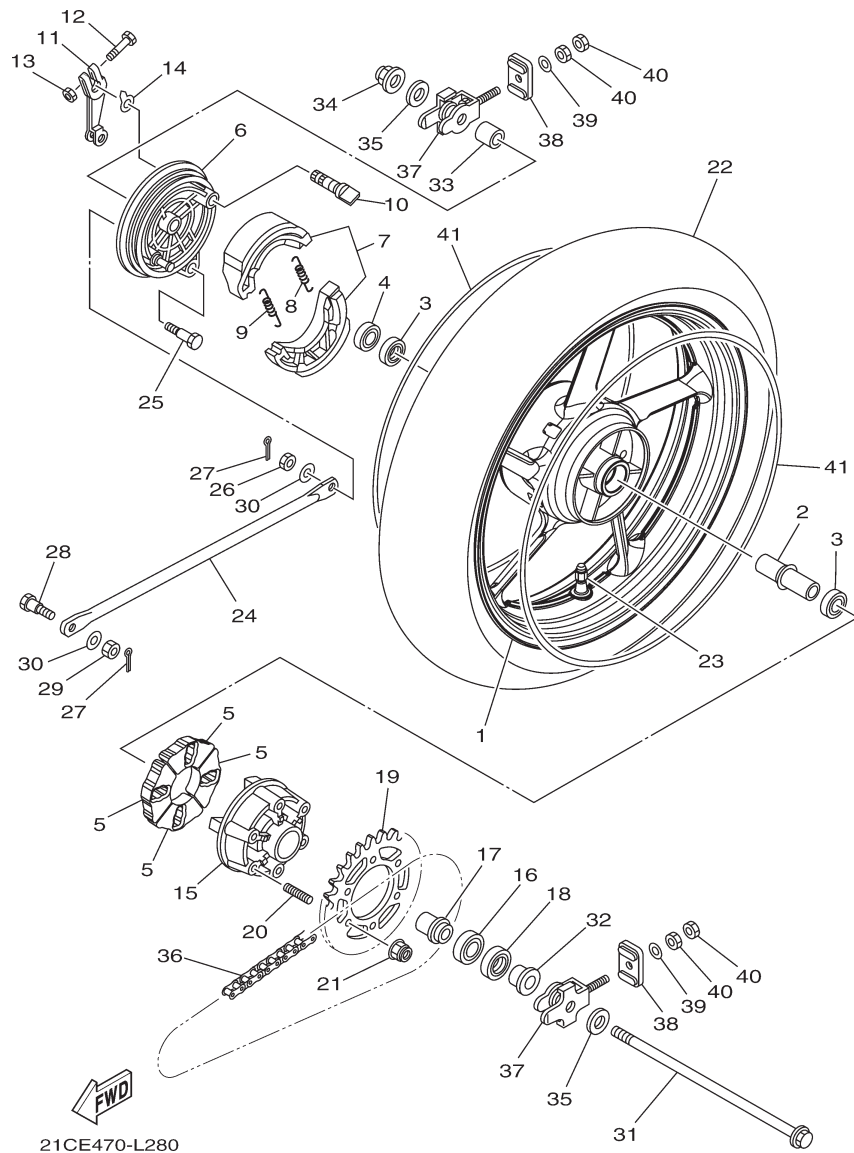
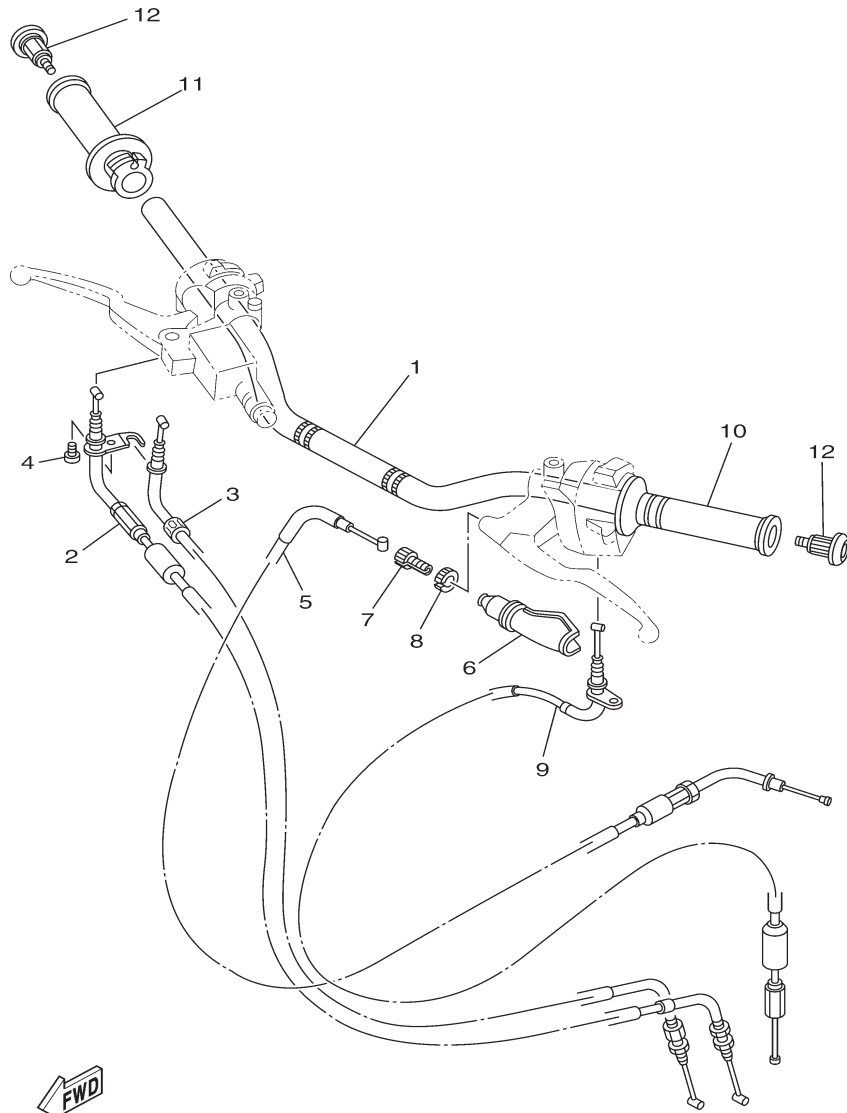

FIG. 28 (4Y0) REAR WHEEL

REF. NO.	PART NO.	PART NAME	21CE				REMARKS
28	90109-08223	BOLT	1				
29	95302-08600	NUT	1				
30	92902-08200	WASHER	2				
31	21C-F5381-00	AXLE, WHEEL	1				
32	21C-F5377-01	COLLAR, WHEEL	1				
33	21C-F5383-10	COLLAR, WHEEL	1				
34	95602-14200	NUT, SELF-LOCKING	1				
35	90201-15837	WASHER, PLATE	2				
36	94568-B5128	CHAIN (R428HBSX-128-2)	1				
37	21C-F5388-11	PULLER, CHAIN 1	2				
38	21C-F2174-00	END 1	2				
39	92902-08600	WASHER, PLATE	2				
40	95302-08600	NUT	4				
41	21C-F531B-31	EMBLEM, WHEEL	2				UR FOR YB
	21C-F531B-50	EMBLEM, WHEEL	2				UR FOR YB
	21C-F531B-60	EMBLEM, WHEEL	2				UR FOR BWC1
	1CK-F531B-00	EMBLEM, WHEEL	2				UR FOR VRC1



21CD470-L290

FIG. 29 (5B0) STEERING HANDLE & CABLE

REF. NO.	PART NO.	PART NAME	21CE				REMARKS
1	21C-F6111-01	HANDLEBAR	1				
2	21C-F6311-20	CABLE, THROTTLE 1	1				
3	21C-F6312-00	CABLE, THROTTLE 2	1				
4	98507-05012	SCREW, PAN HEAD	1				
5	21C-F6335-00	CABLE, CLUTCH	1				
6	4TL-F6372-00	COVER, HANDLE LEVER 1	1				
7	90123-08046	BOLT	1				
8	90179-08148	NUT	1				
9	21C-F6331-10	CABLE, STARTER 1	1				
10	21C-F6241-00	GRIP	1				
11	21C-F6240-10	GRIP ASSY	1				
12	21C-F620B-20	END GRIP ASSY	2				

FIG. 30 (5C0) FRONT MASTER CYLINDER

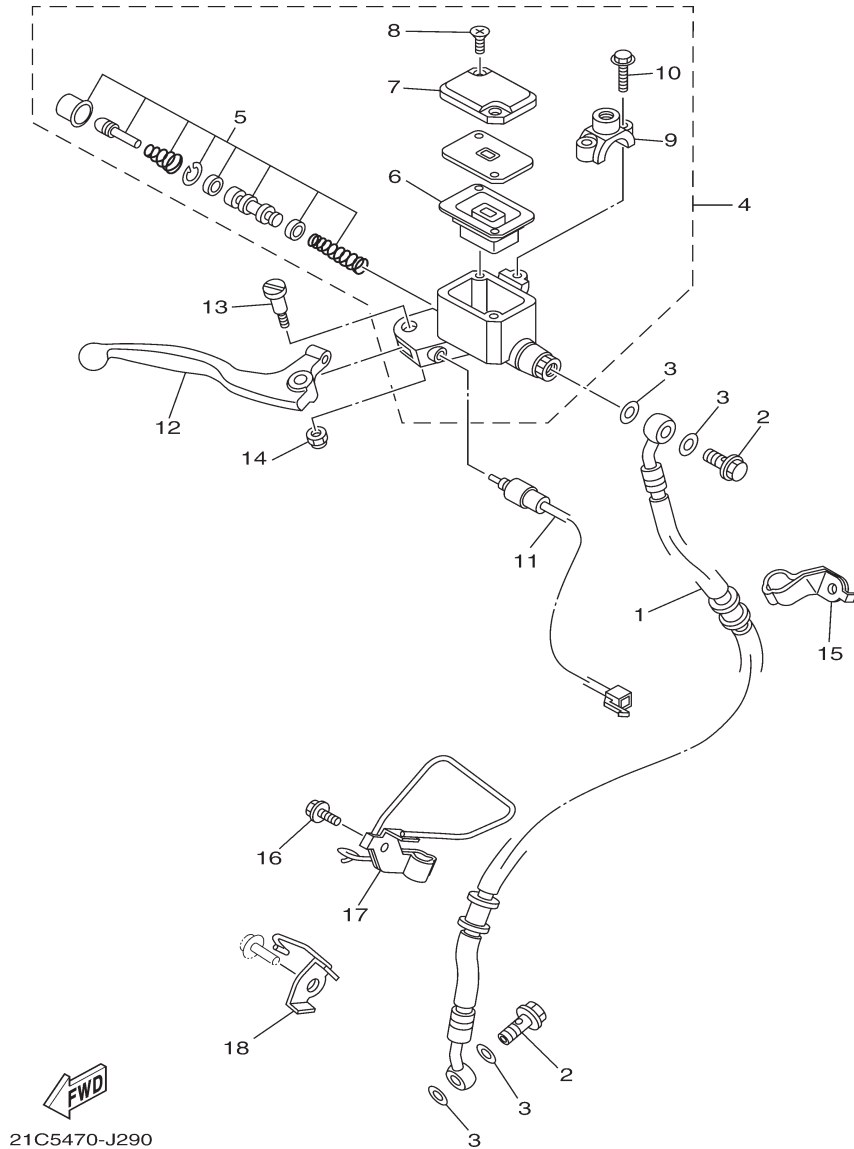

21C5470-J290

REF. NO.	PART NO.	PART NAME	21CE				REMARKS
1	21C-F5872-00	HOSE, BRAKE 1	1				
2	90401-10818	BOLT, UNION	2				
3	90201-10815	WASHER, PLATE	4				
4	21C-F583T-00	MASTER CYLINDER ASSY	1				
5	5US-W0041-00	.CYLINDER KIT, MASTER	1				
6	5US-25854-00	.DIAPHRAGM, RESERVOIR	1				
7	5US-25852-00	.CAP, RESERVOIR	1				
8	98706-04012	.SCREW, FLAT HEAD	2				
9	5YY-F5867-00	.BRACKET, MASTER CYLINDER	1				
10	90105-06859	.BOLT, FLANGE	2				
11	21C-H3980-00	FRONT STOP SWITCH ASSY	1				
12	5YY-H3922-01	LEVER 2	1				
13	90109-06859	BOLT	1				
14	90185-06802	NUT, SELF-LOCKING	1				
15	21C-F5875-00	HOLDER, BRAKE HOSE 1	1				
16	95807-06012	BOLT, FLANGE	1				
17	21C-F5876-00	HOLDER, BRAKE HOSE 2	1				
18	21C-F3317-00	HOLDER, CABLE	1				

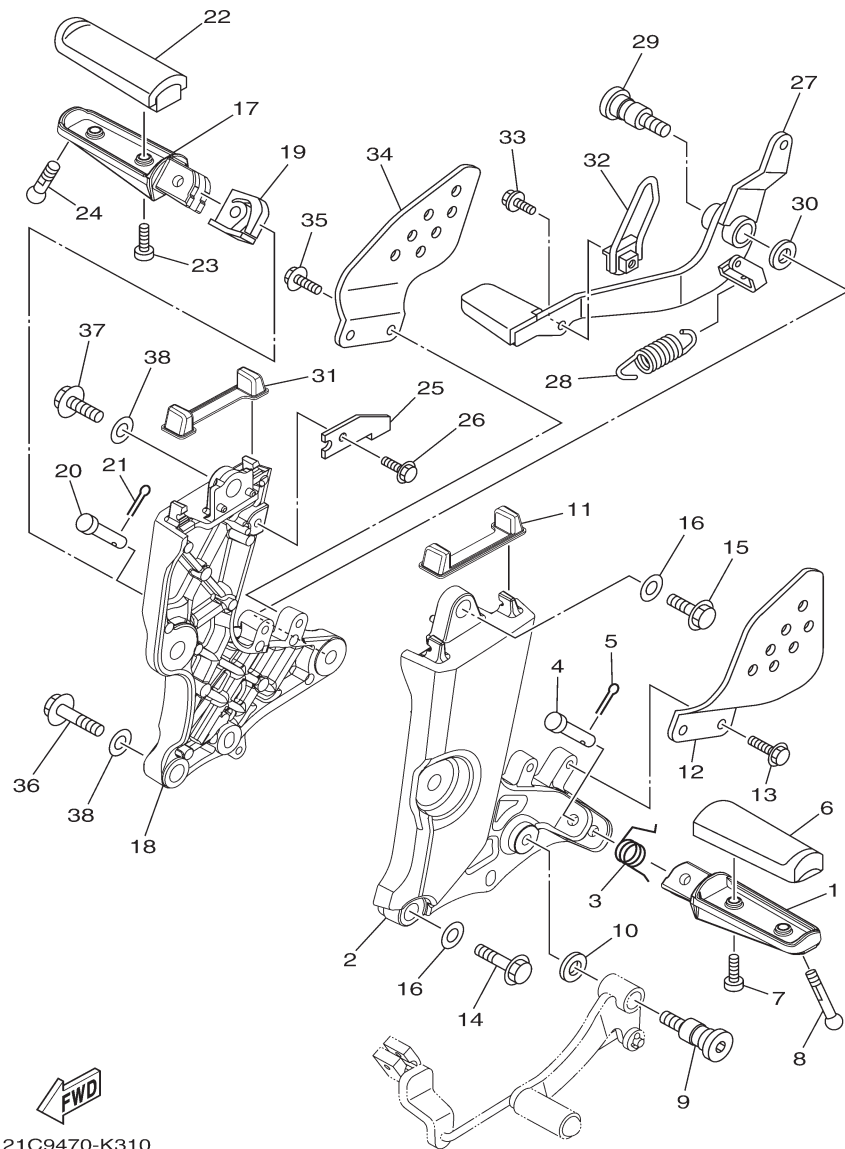

21C9470-K310

FIG. 31 (5F0) STAND & FOOTREST

REF. NO.	PART NO.	PART NAME	21CE				REMARKS
1	35B-F7451-00	FOOTREST	1				
2	21C-F7452-00-P1	BRACKET, FOOTREST 1 -MBL2	1				MBL2
3	90508-183B9	SPRING, TORSION	1				
4	91701-08040	PIN	1				
5	91401-25015	PIN, COTTER	1				
6	21C-F7413-00	COVER, FOOTREST	1				
7	98502-05014	SCREW, PAN HEAD	2				
8	90109-08202	BOLT	1				
9	21C-F7261-00	SHAFT	1				
10	90201-10841	WASHER, PLATE	1				
11	21C-F7414-00	DAMPER, FOOTREST	1				
12	21C-F7445-01	PLATE 1	1				
13	95812-06014	BOLT, FLANGE	2				
14	95812-08035	BOLT, FLANGE	2				
15	95812-08025	BOLT, FLANGE	1				
16	90201-08866	WASHER, PLATE	3				
17	35B-F7461-00	FOOTREST	1				
18	21C-F7462-00-P1	BRACKET, FOOTREST 2 -MBL2	1				MBL2
19	21C-F7426-00	SPRING, RETURN	1				
20	91701-08040	PIN	1				
21	91401-25015	PIN, COTTER	1				
22	21C-F7413-00	COVER, FOOTREST	1				
23	98502-05014	SCREW, PAN HEAD	2				
24	90109-08202	BOLT	1				
25	21C-F144G-00	STAY, STOP SWITCH	1				
26	95802-06010	BOLT, FLANGE	1				
27	21C-F7211-10	PEDAL, BRAKE	1				
28	90506-26807	SPRING, TENSION	1				
29	21C-F7261-00	SHAFT	1				
30	90201-10841	WASHER, PLATE	1				

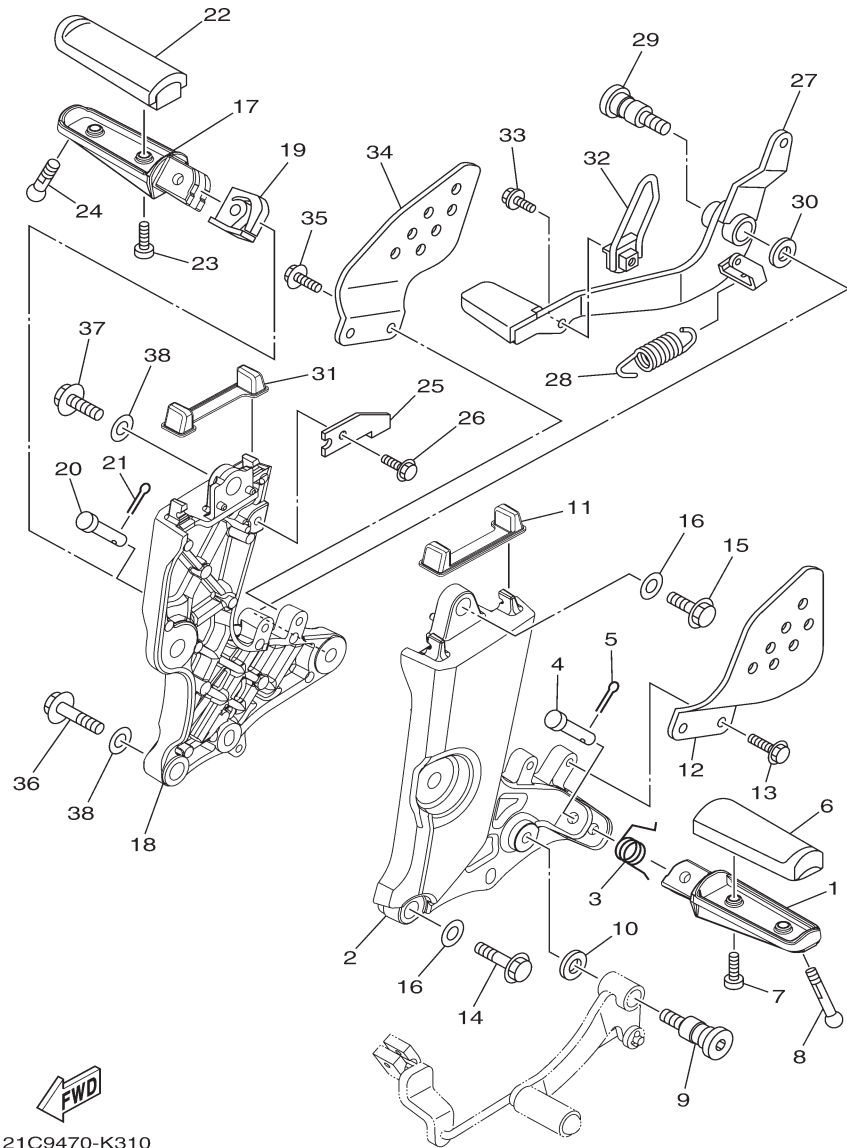

21C9470-K310

FIG. 31 (5F0) STAND & FOOTREST

REF. NO.	PART NO.	PART NAME	21CE				REMARKS
31	21C-F7414-00	DAMPER, FOOTREST	1				
32	21C-F721A-00	GUIDE, PLATE	1				
33	95812-06014	BOLT, FLANGE	1				
34	21C-F7446-01	PLATE 2	1				
35	95812-06014	BOLT, FLANGE	2				
36	95812-08035	BOLT, FLANGE	2				
37	95812-08025	BOLT, FLANGE	1				
38	90201-08866	WASHER, PLATE	3				

FIG. 32 (5F1) STAND & FOOTREST 2

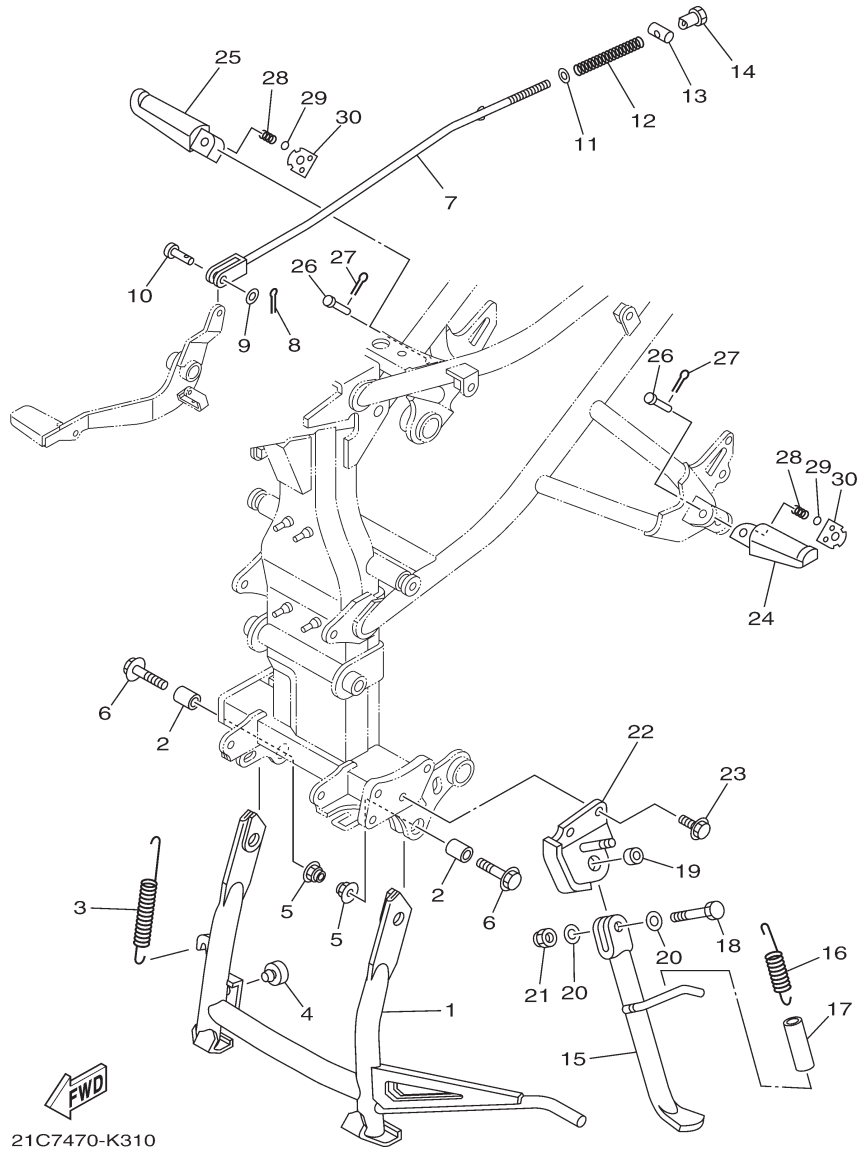

21C7470-K310

REF. NO.	PART NO.	PART NAME	21CE				REMARKS
1	45S-F7111-00	STAND, MAIN	1				
2	90387-10822	COLLAR	2				
3	90506-35816	SPRING, TENSION	1				
4	21C-F7114-00	STOPPER, MAIN STAND	1				
5	95602-10200	NUT, U FLANGE	2				
6	90105-10009	BOLT, FLANGE	2				
7	21C-F7231-00	ROD, BRAKE	1				
8	91401-20012	PIN, COTTER	1				
9	92902-06200	WASHER	1				
10	90240-06804	PIN, CLEVIS	1				
11	92902-06200	WASHER	1				
12	90501-10245	SPRING, COMPRESSION	1				
13	90249-12008	PIN	1				
14	90179-06018	NUT	1				
15	21C-F7311-00	STAND, SIDE	1				
16	90506-23807	SPRING, TENSION	1				
17	90445-13806	HOSE	1				
18	90101-10006	BOLT	1				
19	90387-10003	COLLAR	1				
20	90201-101J1	WASHER, PLATE	2				
21	90185-10811	NUT, SELF-LOCKING	1				
22	21C-F7321-01	BRACKET, SIDE STAND	1				
23	95022-10025	BOLT, FLANGE	2				
24	20P-F7431-00	FOOTREST, REAR 1	1				
25	20P-F7441-00	FOOTREST, REAR 2	1				
26	91701-08035	PIN	2				
27	91401-25015	PIN, COTTER	2				
28	90501-12743	SPRING, COMPRESSION	2				
29	93501-04805	BALL	2				
30	35B-F7437-00	WASHER, SPECIAL	2				

FIG. 33 (8A0) GENERATOR

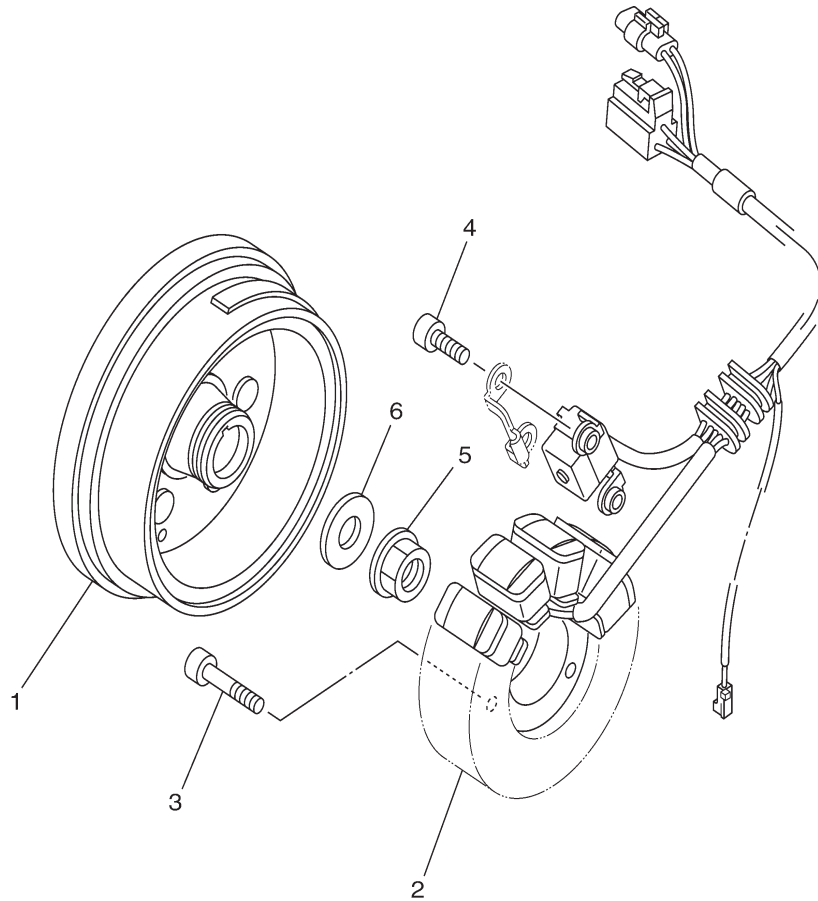

REF. NO.	PART NO.	PART NAME	21CE				REMARKS
1	21C-H1450-10	ROTOR ASSY	1				
2	54B-H1410-00	STATOR ASSY	1				
3	91312-06030	BOLT	3				
4	91312-06016	BOLT	2				
5	95707-12500	NUT, FLANGE	1				
6	90201-122H1	WASHER, PLATE	1				



21C7470-K320

FIG. 34 (8C0) STARTING MOTOR

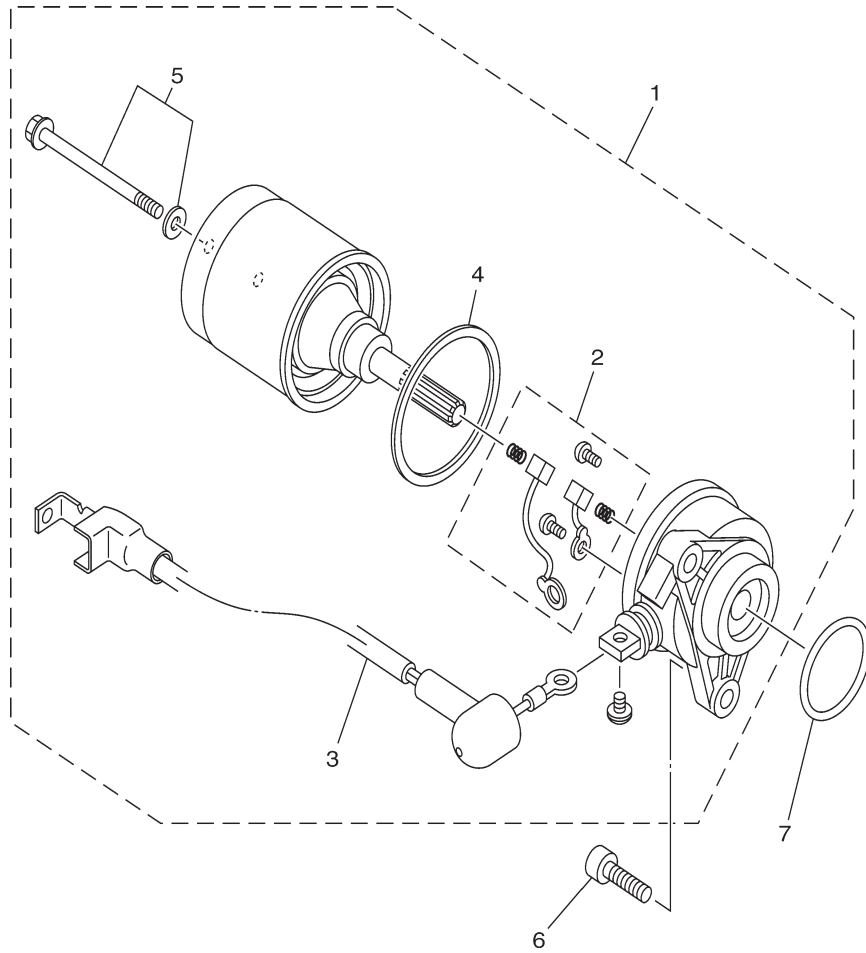

REF. NO.	PART NO.	PART NAME	21CE				REMARKS
1	21C-H1800-10	STARTING MOTOR ASSY	1				
2	5TP-H1801-00	.BRUSH SET	1				
3	21C-H183G-00	.CORD COMP.	1				
4	5D9-H1861-00	.GASKET	1				
5	5D9-H1828-00	.SCREW 2	2				
6	91312-06020	BOLT	2				
7	93210-29807	O-RING	1				



21C7470-K330

FIG 35 (8F0) FLASHER LIGHT

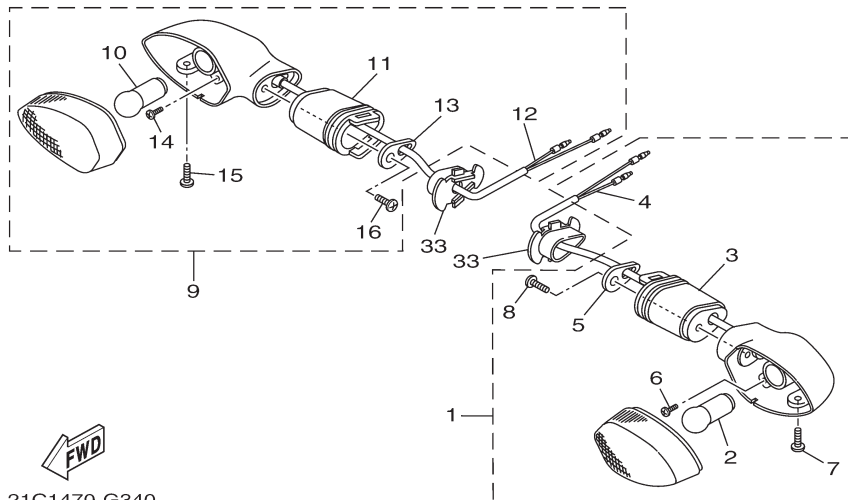
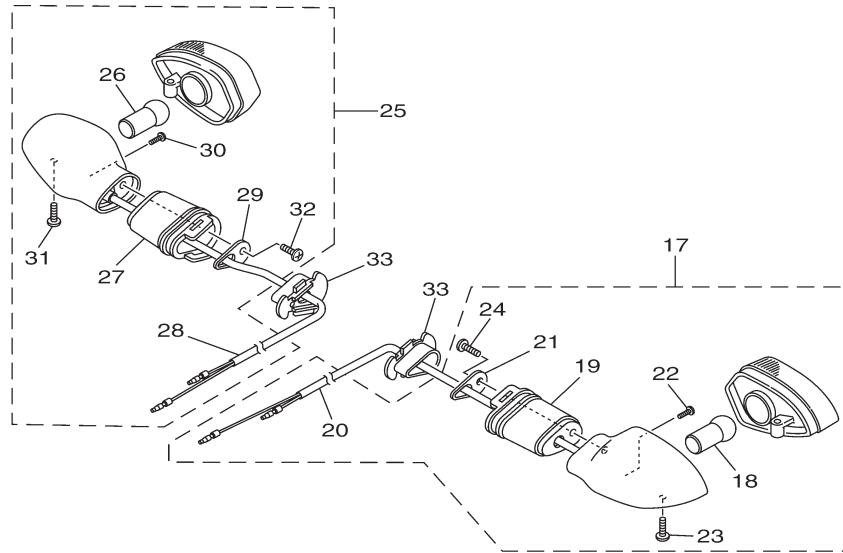

21C1470-G340

REF. NO.	PART NO.	PART NAME	21CE				REMARKS
1	21C-H3310-00	FRONT FLASHER LIGHT ASSY 1	1				
2	21C-H3311-00	.BULB, FLASHER (12V-10W)	1				
3	20P-H3318-10	.STAY, FLASHER 1	1				
4	21C-H331E-00	.CORD ASSY	1				
5	20P-H3618-00	.PLATE	1				
6	20P-H213A-00	.SCREW, FITTING	1				
7	20P-H3333-00	.SCREW, LENS FITTING	1				
8	20P-H2133-00	.SCREW, FITTING	1				
9	21C-H3320-00	FRONT FLASHER LIGHT ASSY 2	1				
10	21C-H3311-00	.BULB, FLASHER (12V-10W)	1				
11	20P-H3318-10	.STAY, FLASHER 1	1				
12	21C-H332E-00	.CORD ASSY	1				
13	20P-H3618-00	.PLATE	1				
14	20P-H213A-00	.SCREW, FITTING	1				
15	20P-H3333-00	.SCREW, LENS FITTING	1				
16	20P-H2133-00	.SCREW, FITTING	1				
17	21C-H3330-00	REAR FLASHER LIGHT ASSY 1	1				
18	21C-H3311-00	.BULB, FLASHER (12V-10W)	1				
19	20P-H3318-00	.STAY, FLASHER 1	1				
20	21C-H355M-00	.CORD ASSY	1				
21	20P-H3618-00	.PLATE	1				
22	20P-H213A-00	.SCREW, FITTING	1				
23	20P-H3333-00	.SCREW, LENS FITTING	1				
24	20P-H2133-00	.SCREW, FITTING	1				
25	21C-H3340-00	REAR FLASHER LIGHT ASSY 2	1				
26	21C-H3311-00	.BULB, FLASHER (12V-10W)	1				
27	20P-H3318-00	.STAY, FLASHER 1	1				
28	21C-H334E-00	.CORD ASS'Y	1				
29	20P-H3618-00	.PLATE	1				
30	20P-H213A-00	.SCREW, FITTING	1				

FIG 35 (8F0) FLASHER LIGHT

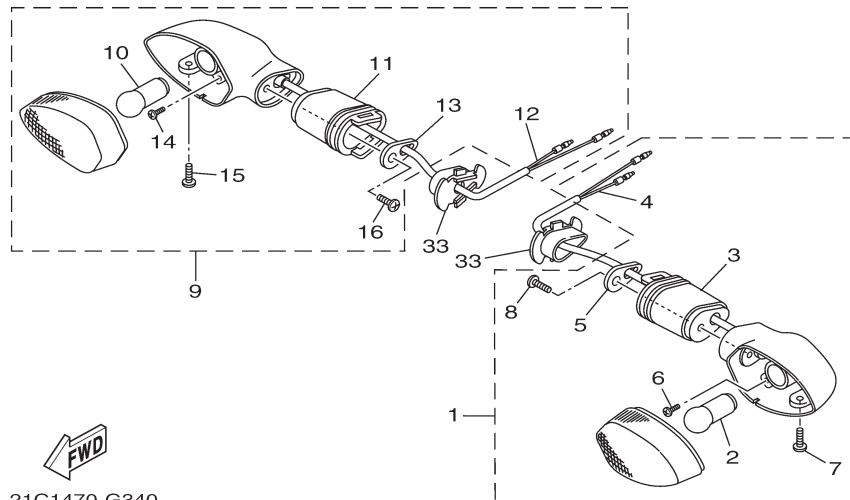
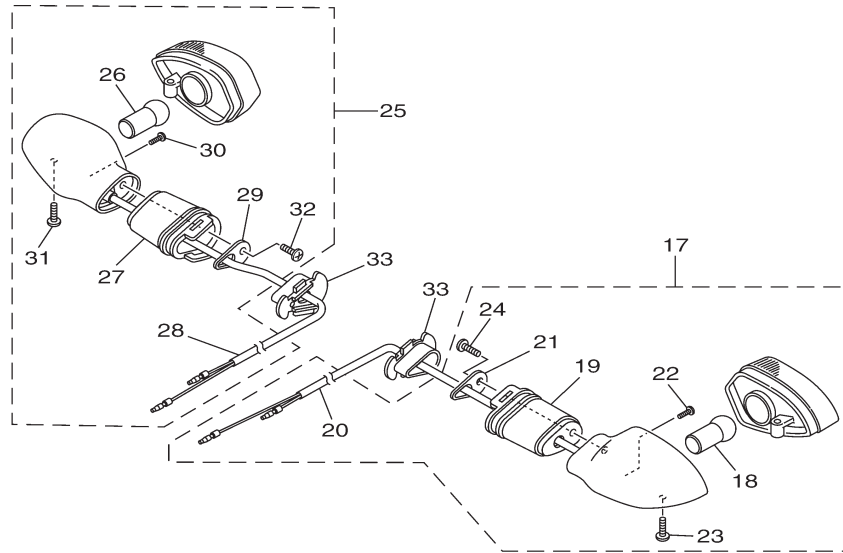

21C1470-G340

REF. NO.	PART NO.	PART NAME	21CE				REMARKS
31	20P-H3333-00	.SCREW, LENS FITTING	1				
32	20P-H2133-00	.SCREW, FITTING	1				
33	5YY-H3318-10	STAY, FLASHER 1	4				

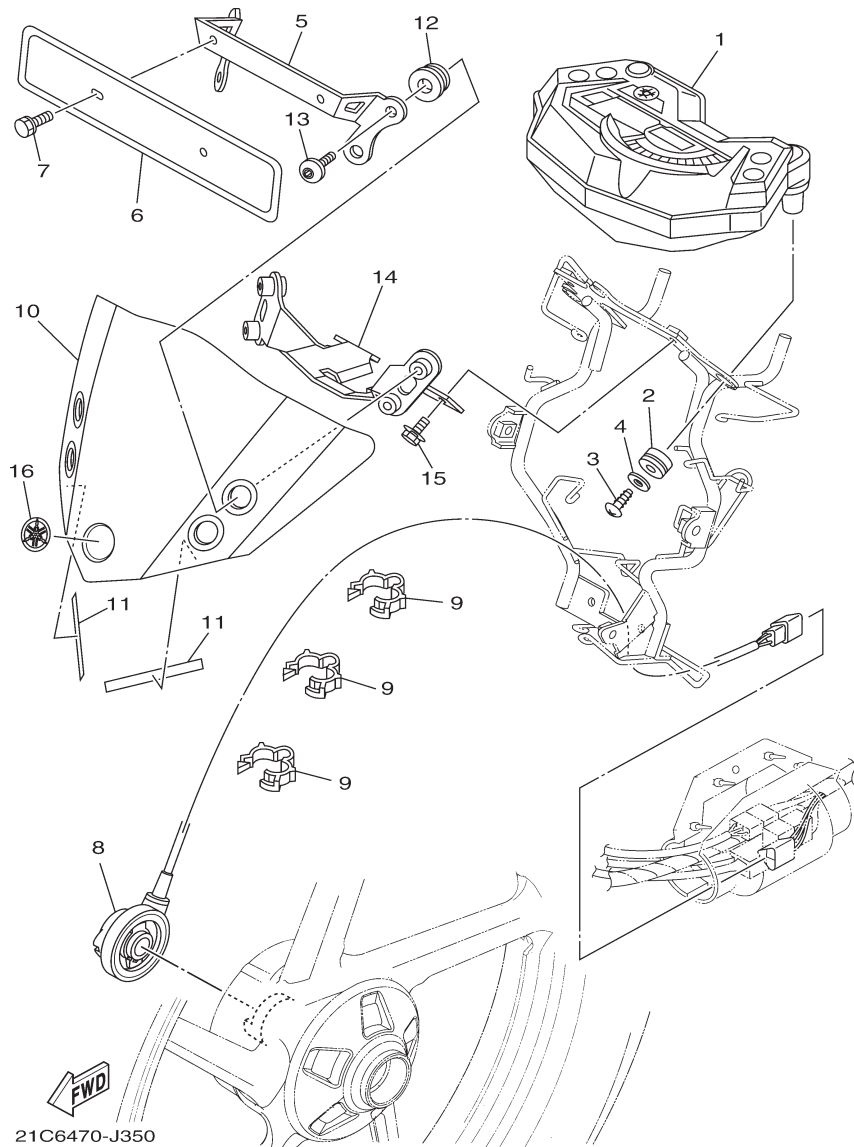
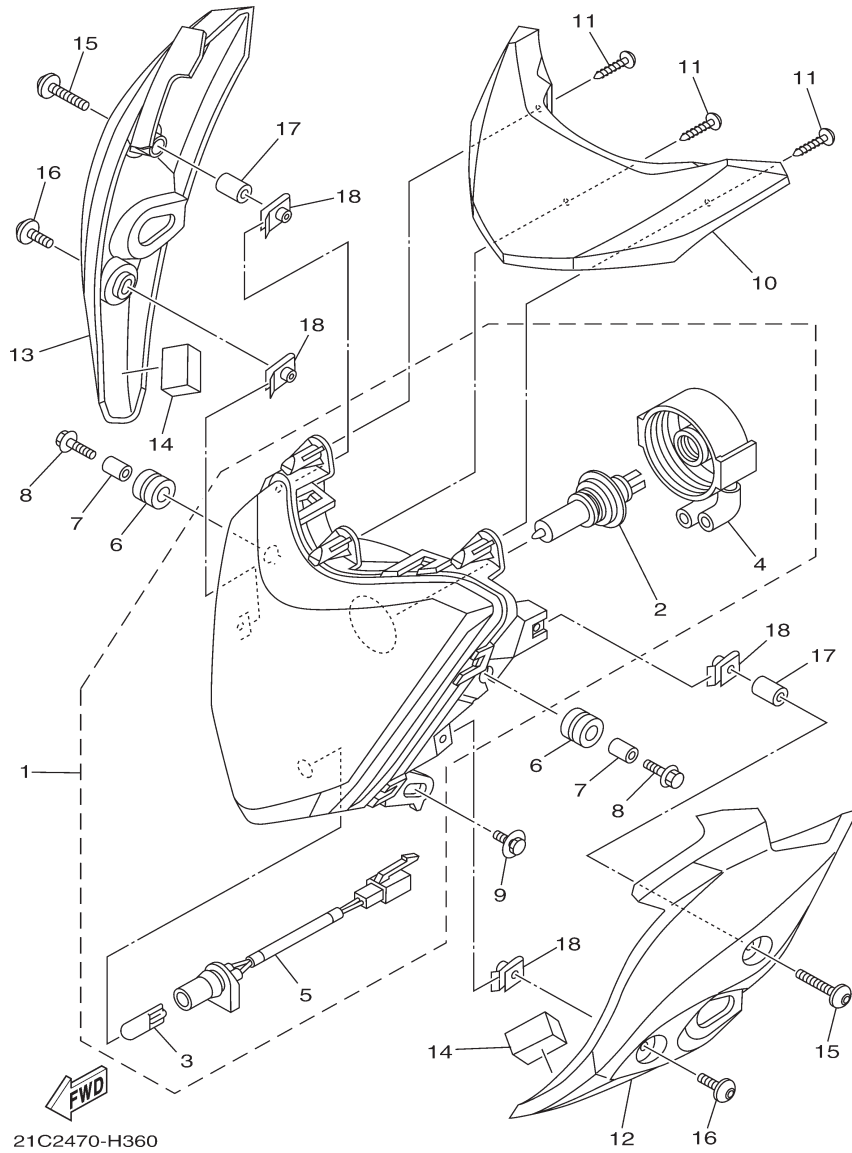

FIG. 36 (8G0) METER

REF. NO.	PART NO.	PART NAME	21CE				REMARKS
1	21C-H3500-60	METERASSY	1				
2	90480-14822	GROMMET	3				
3	97707-50014	SCREW, TRUSS HEAD TAPPING	3				
4	90201-05036	WASHER, PLATE	3				
5	21C-F3487-10	STAY, PLATE	1				
6	5US-F3485-00	PLATE, NUMBER	1				
7	97507-05512	BOLT, WITH WASHER	2				
8	21C-H3756-02	SENSOR, UNIT	1				
9	90464-14803	CLAMP	3				
10	21C-F8381-00	WINDSHIELD	1				
11	21C-F8307-00	SEAL	2				
12	90480-16804	GROMMET	4				
13	90111-06831	BOLT,HEX. SOCKET BUTTON	4				
14	21C-F83E0-00	STAY ASSY. ,1	1				
15	90119-06194	BOLT, WITH WASHER	2				
16	20P-F836B-00	TUNING FORK MARK	1				

FIG 37 (8H0) HEADLIGHT



REF. NO.	PART NO.	PART NAME	21CE				REMARKS
1	21C-H4300-10	HEADLIGHT ASSY	1				
2	21C-H4314-00	.BULB (12V-35/35W)	1				
3	21C-H4347-00	.BULB (12V-5W)	1				
4	21C-H4502-00	.COVER COMP.	1				
5	21C-H4312-00	.CORD ASSY	1				
6	90480-14101	GROMMET	2				
7	90387-068D4	COLLAR	2				
8	95802-06025	BOLT, FLANGE	2				
9	90119-06194	BOLT, WITH WASHER	1				
10	21C-F3121-10-33	COVER, UPPER 1	1				YB
11	97707-40014	SCREW, TAPPING	3				
12	21C-F3122-10-P4	COVER, OUTER 1 -MBL2	1				MBL2
	21C-F3122-10-P5	COVER, OUTER 1 -BWC1	1				BWC1
13	21C-F3132-10-P4	COVER, OUTER 2 -MBL2	1				MBL2
	21C-F3132-10-P5	COVER, OUTER 2 -BWC1	1				BWC1
14	21C-H4527-10	DAMPER	2				
15	90111-06830	BOLT,HEX. SOCKET BUTTON	2				
16	90111-06829	BOLT,HEX. SOCKET BUTTON	2				
17	90387-068E8	COLLAR	2				
18	90183-06821	NUT, SPRING	4				

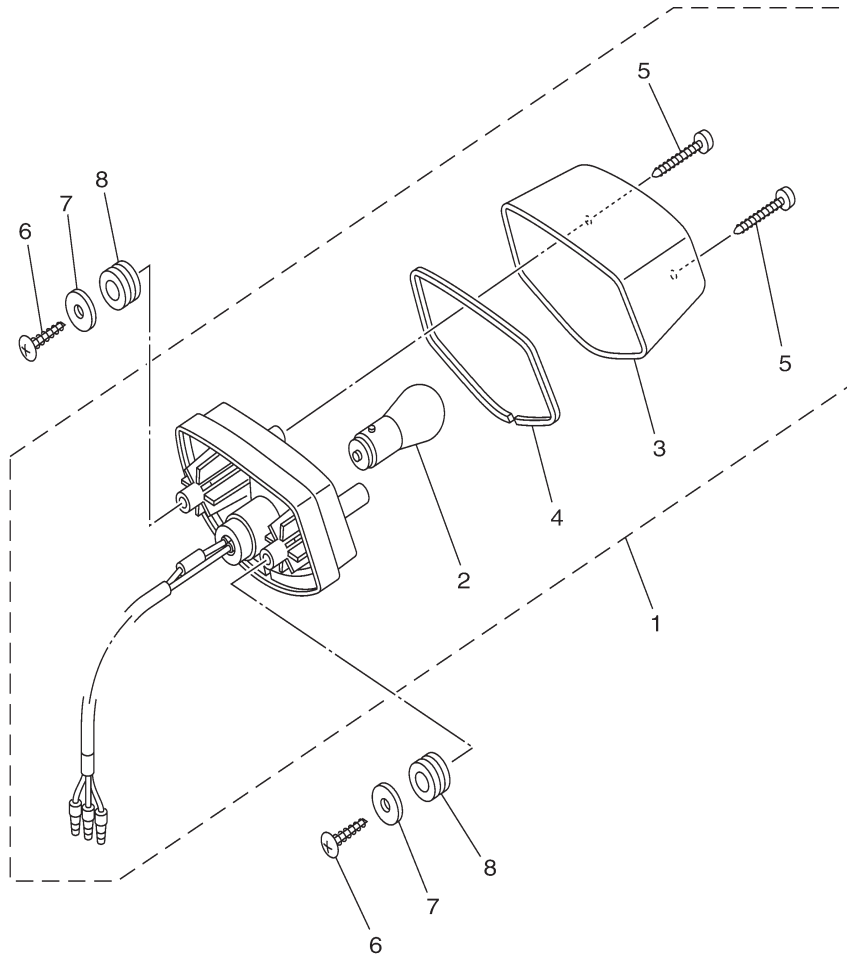

21C1470-G370

FIG. 38 (8J0) TAILLIGHT

REF. NO.	PART NO.	PART NAME	21CE				REMARKS
1	21C-H4710-00	TAILLIGHT UNIT ASSY	1				
2	21C-H4714-00	.BULB (12V-21/5W)	1				
3	21C-H4721-00	.LENS, TAILLIGHT	1				
4	21C-H4723-00	.GASKET, TAIL LENS	1				
5	97702-40030	.SCREW, TAPPING	2				
6	97702-50025	SCREW, TAPPING	2				
7	90201-05036	WASHER, PLATE	2				
8	90480-14819	GROMMET	2				

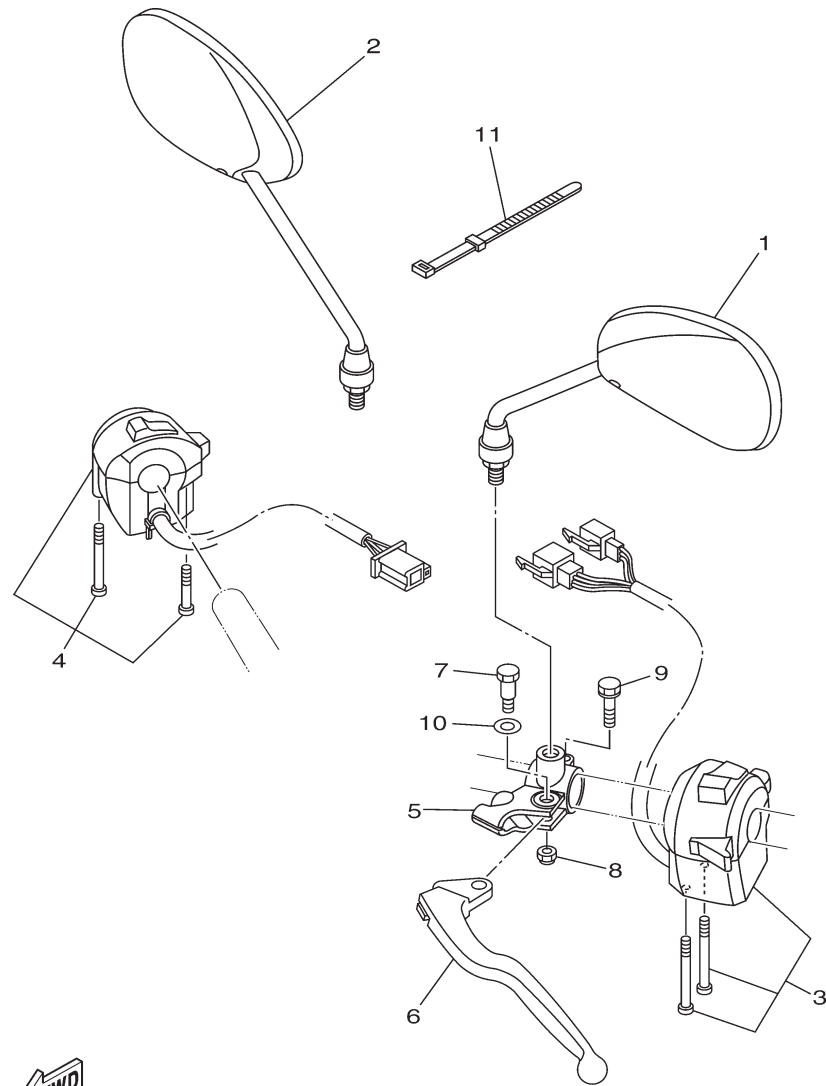

FIG. 39 (8T0) HANDLE SWITCH & LEVER

REF. NO.	PART NO.	PART NAME	21CE				REMARKS
1	21C-F6280-00	REAR VIEW MIRROR ASSY (LEFT)	1				
2	21C-F6290-00	REAR VIEW MIRROR ASSY (RIGHT)	1				
3	21C-H3972-01	SWITCH, HANDLE 4	1				
4	21C-H3963-20	SWITCH, HANDLE 3	1				
5	5YY-H2911-00	HOLDER, LEVER 1	1				
6	21C-H3912-00	LEVER 1	1				
7	36L-H3945-10	BOLT, LEVER	1				
8	95707-06300	NUT, NYLON	1				
9	9750M-06425	BOLT, WITH WASHER	1				
10	90201-08834	WASHER, PLATE	1				
11	36L-H3936-00	BAND, SWITCH CORD	2				



21C1470-G380

FIG. 40 (8V0) ELECTRICAL 1

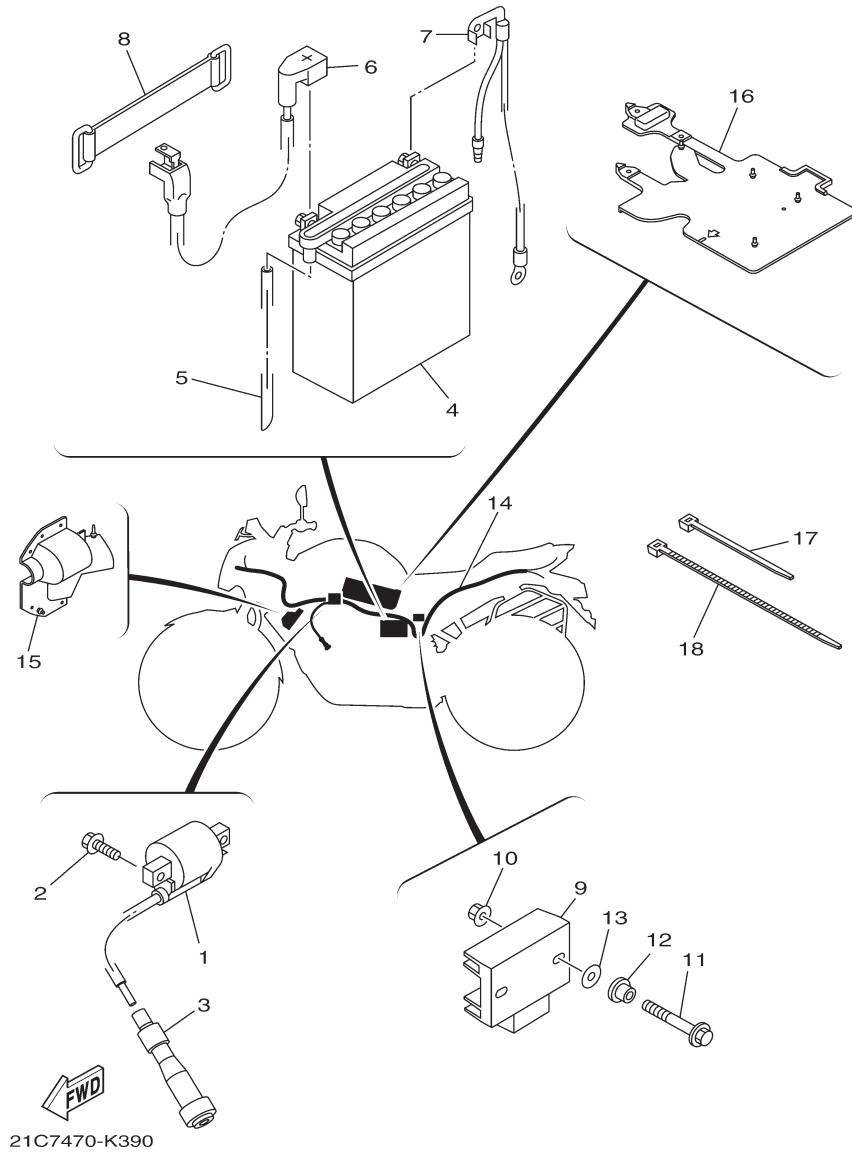

REF. NO.	PART NO.	PART NAME	21CE				REMARKS
1	21C-H2310-00	IGNITION COIL ASSY	1				
2	95027-06020	BOLT, FLANGE	2				
3	20P-H2370-01	PLUG CAP ASSY	1				
4	35B-H2110-00	BATTERY ASSY (EXIDE 12MX5L-B)	1				UR
	21C-H2110-00	BATTERY ASSY (MINDA MLX-5LE)	1				UR
5	90446-07805	HOSE	1				
6	21C-H2115-10	WIRE, PLUS LEAD	1				
7	21C-H2116-10	WIRE, MINUS LEAD	1				
8	5YY-H2131-10	BAND, BATTERY	1				
9	54B-H1960-00	RECTIFIER & REGULATOR ASSY	1				
10	95702-06500	NUT, FLANGE	2				
11	95812-06025	BOLT, FLANGE	2				
12	90387-06048	COLLAR	2				
13	90202-05807	WASHER, PLATE	2				
14	21C-H2590-31	WIRE HARNESS ASSY	1				
15	21C-H2599-00	COVER, CONNECTER	1				
16	21C-H252U-00	COVER	1				
17	90464-16061	CLAMP	3				
18	90464-80802	CLAMP	1				

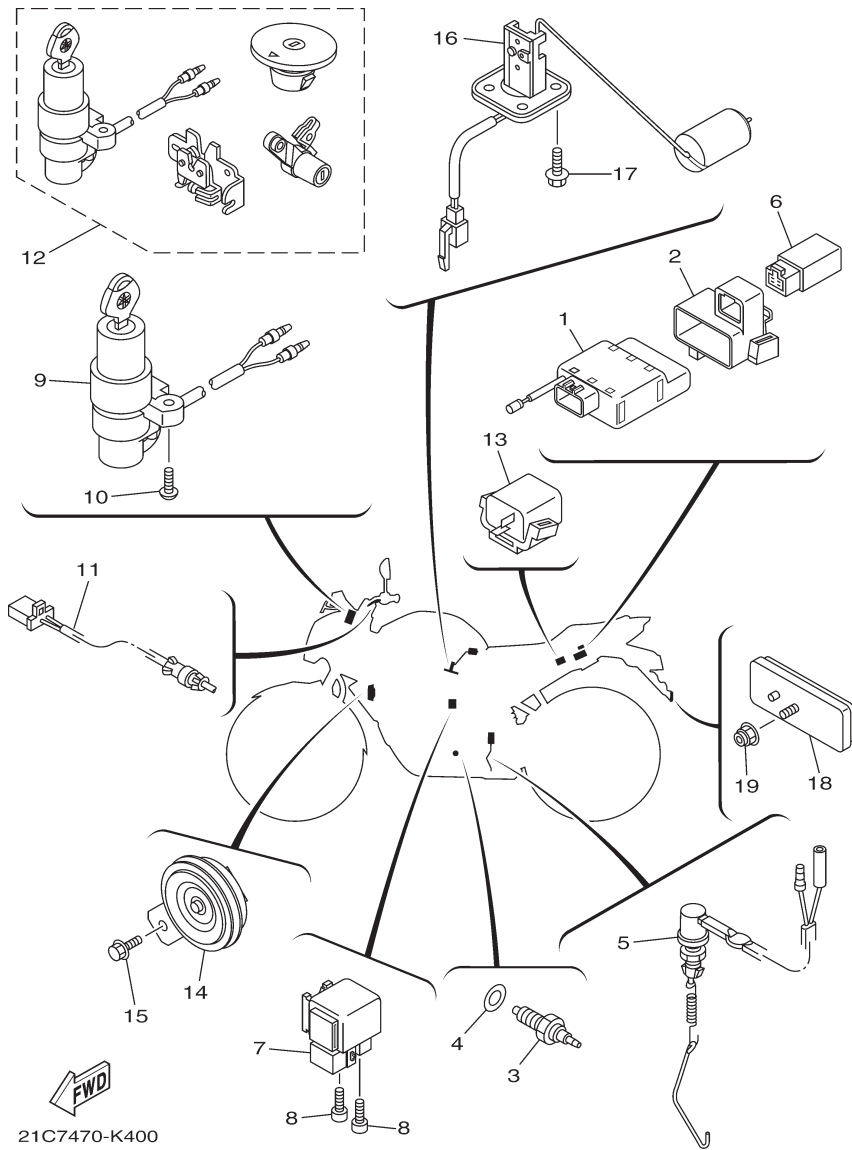

21C7470-K400

FIG. 41 (8W0) ELECTRICAL 2

REF. NO.	PART NO.	PART NAME	21CE				REMARKS
1	21C-H5540-10	C.D.I. UNIT ASSY	1				
2	21C-H5546-10	BAND	1				
3	21C-H2540-00	NEUTRAL SWITCH ASSY	1				
4	90430-10148	GASKET	1				
5	21C-H2530-00	STOP SWITCH ASSY	1				
6	21C-H1951-01	RELAY	1				
7	21C-H1940-10	STARTER RELAY ASSY	1				
8	91312-05008	BOLT	2				
9	21C-H2501-30	MAIN SWITCH STEERING LOCK	1				
10	90149-06118	SCREW	2				
11	21C-H2917-00	SWITCH	1				
12	21C-XH250-30	MAIN SW. STRG. LOCK SUB ASSY	1				AP
13	21C-H3350-00	FLASHER RELAY ASSY	1				
14	21C-H3371-00	HORN	1				
15	95802-06012	BOLT, FLANGE	1				
16	21C-H5701-02	SENDER ASSY	1				
17	90119-05022	BOLT, WITH WASHER	4				
18	5US-H5110-00	REFLECTOR ASSY	1				
19	95702-05500	NUT, FLANGE	1				

21CE

PART NO	REF. NO.	PART NO	REF. NO.	PART NO	REF. NO.	PART NO	REF. NO.	PART NO	REF. NO.	PART NO	REF. NO.
1CK-F531B-00	26-11	21C-1414M-41	7-8	21C-E3586-01	6-1	21C-E7231-30	14-11	21C-F3110-00	22-18	21C-F4216-10	24-17
1CK-F531B-00	28-41	21C-14191-00	7-23	21C-E3595-00	6-7	21C-E7241-40	14-13	21C-F3110-00	22-35	21C-F4311-00	23-27
1PM-E1165-00	1-6	21C-14216-00	7-33	21C-E4411-00	6-10	21C-E7251-40	14-10	21C-F3111-00	22-5	21C-F4318-00	23-13
1PM-E1190-00	1-5	21C-14275-00	7-27	21C-E4412-00	6-11	21C-E7258-00	14-15	21C-F3111-00	22-22	21C-F4500-10	23-18
1PM-E2280-00	4-5	21C-14340-00	7-26	21C-E443E-00	6-16	21C-E7402-40	14-6	21C-F3114-00	22-4	21C-F4614-00-P0	23-14
1PM-E2288-00	4-6	21C-14545-00	7-28	21C-E4450-00	6-12	21C-E7410-40	14-1	21C-F3114-00	22-21	21C-F470J-00-P0	25-11
1PM-E5524-00	12-5	21C-1490J-10	7-5	21C-E4452-00	6-14	21C-E7471-00	14-4	21C-F3118-00	22-6	21C-F470K-00-P0	25-14
1PM-E8511-00	15-2	21C-14958-10	7-25	21C-E4453-00	6-13	21C-E8101-01	16-4	21C-F3118-00	22-23	21C-F472T-10	25-9
1PM-E8512-00	15-3	21C-1496A-00	7-30	21C-E446R-00	6-20	21C-E8110-10	16-9	21C-F3121-10-33	37-10	21C-F4730-20	25-1
1PM-E8513-00	15-4	21C-14987-00	7-31	21C-E4485-00	6-19	21C-E8140-00	16-1	21C-F3122-10-P4	37-12	21C-F4780-01	25-4
20P-E4747-00	8-10	21C-16345-10	13-23	21C-E449E-10	6-37	21C-E8337-00	16-3	21C-F3122-10-P5	37-12	21C-F478E-01	25-6
20P-E4747-00	17-16	21C-85885-00	7-32	21C-E4613-00	8-11	21C-E8531-00	15-5	21C-F3126-11	22-3	21C-F510C-10	26-2
20P-E8113-00	16-10	21C-E111F-00	4-4	21C-E4703-10	8-1	21C-E8535-00	15-6	21C-F3132-10-P4	37-13	21C-F5168-20-33	26-1
20P-F2129-00	20-6	21C-E1161-00	1-27	21C-E4718-10	8-2	21C-E8540-30	15-1	21C-F3132-10-P5	37-13	21C-F5181-00	26-8
20P-F3418-00	21-8	21C-E1161-10	1-28	21C-E4775-00	8-9	21C-F1110-20	17-1	21C-F3136-11	22-20	21C-F5183-01	26-7
20P-F4741-00	25-2	21C-E1161-20	1-29	21C-E4799-01	8-3	21C-F117K-00	25-8	21C-F3141-00	22-8	21C-F530S-10	28-2
20P-F5366-00-33	28-15	21C-E1166-10	6-25	21C-E4815-00	6-29	21C-F1298-10	17-11	21C-F3141-00	22-25	21C-F531B-31	26-11
20P-F5377-00	28-17	21C-E1193-00	1-11	21C-E4872-00	6-28	21C-F1316-00	17-2	21C-F3146-00	22-15	21C-F531B-31	28-41
20P-F7431-00	32-24	21C-E1351-00	1-23	21C-E4877-00	6-18	21C-F1317-00	17-5	21C-F3146-00	22-32	21C-F531B-50	26-11
20P-F7441-00	32-25	21C-E1400-09	2-1	21C-E4881-00	6-31	21C-F144G-00	31-25	21C-F3149-00	22-7	21C-F510C-10	28-41
20P-F836B-00	36-16	21C-E1422-00	2-5	21C-E4882-00	6-32	21C-F1511-00-2X	18-1	21C-F3149-00	22-24	21C-F531B-60	26-11
20P-H2133-00	35-8	21C-E1496-20	2-16	21C-E4901-40	7-1	21C-F1511-00-7X	18-1	21C-F3156-00	22-13	21C-F531B-60	28-41
20P-H2133-00	35-16	21C-E1531-00	2-15	21C-E5113-00	10-12	21C-F1511-00-8X	18-1	21C-F3156-00	22-30	21C-F5338-20-33	28-1
20P-H2133-00	35-24	21C-E1603-00	2-11	21C-E5155-00	9-3	21C-F1611-01	18-7	21C-F3158-00	22-10	21C-F5355-01	28-11
20P-H2133-00	35-32	21C-E1605-00	2-11	21C-E5411-10	10-3	21C-F1621-00	18-22	21C-F3158-00	22-27	21C-F5364-00	28-5
20P-H213A-00	35-6	21C-E1607-00	2-11	21C-E5418-01	10-13	21C-F1638-01	17-18	21C-F3170-00	22-17	21C-F5371-00	28-24
20P-H213A-00	35-14	21C-E1631-00	2-8	21C-E5421-00	10-18	21C-F1650-00	20-13	21C-F3170-00	22-34	21C-F5377-01	28-32
20P-H213A-00	35-22	21C-E1633-00	2-9	21C-E542A-00	10-17	21C-F1651-00	18-8	21C-F3173-00	22-11	21C-F5381-00	28-31
20P-H213A-00	35-30	21C-E1636-09	2-8	21C-E5441-00	10-1	21C-F1669-00	18-16	21C-F3173-00	22-28	21C-F5383-10	28-33
20P-H2370-01	40-3	21C-E1638-09	2-8	21C-E5514-10	12-1	21C-F1681-00	18-18	21C-F3174-30	21-16	21C-F5388-11	28-37
20P-H3618-00	35-19	21C-E1651-00	2-4	21C-E5521-00	12-2	21C-F16A2-00	18-17	21C-F317J-00	21-17	21C-F5440-00	28-19
20P-H3318-00	35-27	21C-E1681-01	2-2	21C-E5620-00	11-18	21C-F1717-00	18-13	21C-F3181-00	22-9	21C-F582U-00	27-1
20P-H3318-10	35-3	21C-E2113-00	3-5	21C-E5641-10	11-2	21C-F1717-00	19-9	21C-F3181-00	22-26	21C-F583T-00	30-4
20P-H3318-10	35-11	21C-E2119-00	3-3	21C-E5671-00	11-6	21C-F172A-10	19-2	21C-F3317-00	30-18	21C-F5872-00	30-1
20P-H3333-00	35-7	21C-E2126-00	3-4	21C-E5674-00	11-13	21C-F172F-10	19-6	21C-F3340-00	22-36	21C-F5875-00	30-15
20P-H3333-00	35-15	21C-E2151-00	3-8	21C-E5767-00	11-7	21C-F177G-10	18-12	21C-F3346-00	22-39	21C-F5876-00	30-17
20P-H3333-00	35-23	21C-E2156-00	3-11	21C-E6135-10	13-19	21C-F2141-00	20-5	21C-F3435-00	21-10	21C-F6111-01	29-1
20P-H3333-00	35-31	21C-E2170-00	4-1	21C-E6154-00	13-7	21C-F2147-00	20-14	21C-F3441-00	21-14	21C-F620B-20	29-12
20P-H3618-00	35-5	21C-E2210-00	4-13	21C-E6193-00	13-3	21C-F2151-00	20-9	21C-F3487-10	36-5	21C-F6240-10	29-11
20P-H3618-00	35-13	21C-E2231-00	4-9	21C-E6324-00	13-11	21C-F2174-00	28-38	21C-F4110-00	23-1	21C-F6241-00	29-10
20P-H3618-00	35-21	21C-E2241-00	4-10	21C-E6331-00	13-10	21C-F2184-00	20-2	21C-F411G-10	23-29	21C-F6280-00	39-1
20P-H3618-00	35-29	21C-E2437-00	4-17	21C-E6333-00	13-13	21C-F2210-00	20-17	21C-F411J-10	23-30	21C-F6290-00	39-2
21C-12117-00	3-7	21C-E2661-10	1-24	21C-E6337-00	13-14	21C-F281A-00	25-12	21C-F4124-10	23-32	21C-F6311-20	29-2
21C-12159-00	3-9	21C-E3362-00	2-20	21C-E6356-01	13-16	21C-F281E-00	25-15	21C-F414A-00	23-12	21C-F6312-00	29-3
21C-14103-00	7-6	21C-E3440-00	5-6	21C-E6358-00	13-15	21C-F281F-00	25-13	21C-F414H-10	24-3	21C-F6331-10	29-9
21C-14105-00	7-4	21C-E3447-00	5-7	21C-E6371-00	13-8	21C-F281G-00	25-16	21C-F4181-00	23-2	21C-F6335-00	29-5
21C-1410A-10	7-3	21C-E3449-00	5-10	21C-E6380-01	13-22	21C-F3100-11	22-1	21C-F4182-00	23-3	21C-F7114-00	32-4
21C-1410E-10	7-34	21C-E3536-01	6-2	21C-E7211-20	14-16	21C-F3102-11	22-2	21C-F4183-00	23-4	21C-F7211-10	31-27
21C-14147-00	7-29	21C-E3542-00	6-8	21C-E7221-20	14-7	21C-F3103-11	22-19	21C-F4188-10	23-10	21C-F721A-00	31-32

21CE

PART NO	REF. NO.	PART NO	REF. NO.	PART NO	REF. NO.	PART NO	REF. NO.	PART NO	REF. NO.	PART NO	REF. NO.
21C-F7231-00	32-7	21C-H3756-02	36-8	21C-XF413-U0-P5	24-2	54B-E2121-00	3-2	5US-W0016-00	27-10	90119-06117	18-15
21C-F7261-00	31-9	21C-H3912-00	39-6	21C-XF413-V0-P4	24-2	54B-E2435-00	1-14	5US-W0041-00	30-5	90119-06137	19-18
21C-F7261-00	31-29	21C-H3963-20	39-4	21C-XH250-30	41-12	54B-E3300-00	5-1	5US-W0045-00	27-7	90119-06194	36-15
21C-F7311-00	32-15	21C-H3972-01	39-3	22F-12118-01	3-6	54B-E5111-00	9-1	5US-W0047-00	27-4	90119-06194	37-9
21C-F7321-01	32-22	21C-H3980-00	30-11	22F-14137-00	7-18	54B-E5121-00	9-2	5US-W0048-00	27-6	90123-08046	29-7
21C-F7413-00	31-6	21C-H4300-10	37-1	22F-14139-00	7-16	54B-E5362-00	10-22	5US-W0053-00	27-12	90149-06108	23-25
21C-F7413-00	31-22	21C-H4312-00	37-5	22F-14953-00	7-19	54B-E5451-00	10-4	5US-W0068-00	27-11	90149-06118	41-10
21C-F7414-00	31-11	21C-H4314-00	37-2	2A2-14997-00	7-21	54B-E5461-00	10-19	5YP-14561-00	7-17	90154-06061	18-6
21C-F7414-00	31-31	21C-H4347-00	37-3	353-14186-00	7-14	54B-E5580-00	12-8	5YY-14150-00	7-2	90159-05065	23-15
21C-F7426-00	31-19	21C-H4502-00	37-4	35B-F7437-00	32-30	54B-E5661-00	11-1	5YY-F3416-00	21-6	90159-05065	24-9
21C-F7445-01	31-12	21C-H4527-10	37-14	35B-F7451-00	31-1	54B-E5664-10	11-11	5YY-F3462-00	22-37	90159-06021	18-19
21C-F7446-01	31-34	21C-H4710-00	38-1	35B-F7461-00	31-17	54B-E5665-00	11-12	5YY-F5351-00	28-10	90159-06054	25-10
21C-F7452-00-P1	31-2	21C-H4714-00	38-2	35B-H2110-00	40-4	54B-E6111-00	13-1	5YY-F580U-20	27-3	90170-06128	3-10
21C-F7462-00-P1	31-18	21C-H4721-00	38-3	36L-F533A-00	28-14	54B-E6144-00	13-17	5YY-F5867-00	30-9	90170-10405	2-26
21C-F8100-20	17-19	21C-H4723-00	38-4	36L-H3936-00	39-11	54B-E6150-00	13-6	5YY-H2131-10	40-8	90176-22081	21-13
21C-F8307-00	36-11	21C-H5540-10	41-1	36L-H3945-10	39-7	54B-E6321-00	13-9	5YY-H2911-00	39-5	90179-05523	23-16
21C-F8381-00	36-10	21C-H5546-10	41-2	3C1-E6344-00	13-18	54B-E6351-00	13-12	5YY-H3318-10	35-33	90179-05523	24-10
21C-F83E0-00	36-14	21C-H5701-02	41-16	3G2-1423A-73	7-7	54B-E6357-00	13-24	5YY-H3922-01	30-12	90179-06018	32-14
21C-H1450-10	33-1	21C-WF211-10	20-1	45P-E4803-10	6-35	54B-E7258-00	13-2	5YY-WF533-00	28-7	90179-08148	29-8
21C-H1800-10	34-1	21C-WF461-10	23-17	45P-E5651-00	11-15	54B-F4512-10	23-19	6K8-14597-10	7-20	90179-08674	17-8
21C-H183G-00	34-3	21C-WF479-00	25-7	45S-F7111-00	32-1	54B-F4514-10	23-20	90101-06046	28-12	90179-10658	17-4
21C-H1940-10	41-7	21C-XF137-B0-P3	24-11	45S-XF171-20-P1	19-1	54B-F4521-10	23-21	90101-10006	32-18	90179-12659	11-19
21C-H1951-01	41-6	21C-XF137-C0-P4	24-11	45S-XF172-20-P1	19-5	54B-F4535-10	23-24	90105-06859	30-10	90179-12802	13-5
21C-H2110-00	40-4	21C-XF137-D0-P5	24-11	4EB-23144-00	22-12	54B-F4564-10	23-22	90105-08196	4-7	90179-14001	13-20
21C-H2115-10	40-6	21C-XF13A-B0-P3	24-12	4EB-23144-00	22-29	54B-F4598-10	23-23	90105-08197	1-17	90179-25615	21-7
21C-H2116-10	40-7	21C-XF13A-C0-P4	24-12	4EB-23145-01	22-14	54B-H1410-00	33-2	90105-10009	32-6	90183-05061	24-8
21C-H2310-00	40-1	21C-XF13A-D0-P5	24-12	4EB-23145-01	22-16	54B-H1960-00	40-9	90105-10174	17-10	90183-05818	18-11
21C-H2501-30	41-9	21C-XF173-L0-33	19-11	4FM-23125-40	22-31	583-14561-00	7-13	90105-10319	27-13	90183-05818	19-3
21C-H252U-00	40-16	21C-XF173-M0-P1	19-11	4FM-23125-40	22-33	5D9-H1828-00	34-5	90105-12057	20-19	90183-05818	19-7
21C-H2530-00	41-5	21C-XF173-N0-P2	19-11	4KM-14216-00	7-22	5D9-H1861-00	34-4	90105-12085	20-20	90183-05818	19-13
21C-H2540-00	41-3	21C-XF173-P0-33	19-11	4LS-E3411-00	5-5	5DG-F1778-00	19-10	90109-06259	16-2	90183-05818	24-15
21C-H2590-31	40-14	21C-XF174-L0-33	19-12	4LS-E5598-00	4-11	5GH-14918-10	7-10	90109-06859	30-13	90183-06802	6-22
21C-H2599-00	40-15	21C-XF174-M0-P1	19-12	4LS-E7456-00	14-21	5KA-F3411-00	22-38	90109-08063	28-25	90183-06821	37-18
21C-H2917-00	41-11	21C-XF174-N0-P2	19-12	4LS-F341E-00	21-5	5KA-F3412-00	21-1	90109-08202	31-8	90185-06802	30-14
21C-H3310-00	35-1	21C-XF174-P0-33	19-12	4LS-F341E-10	21-4	5KA-F3413-00	21-2	90109-08202	31-24	90185-10811	32-21
21C-H3311-00	35-2	21C-XF17C-F0-P1	19-15	4LS-F4741-00	18-14	5KA-F3414-00	21-3	90109-08223	28-28	90201-05015	1-25
21C-H3311-00	35-10	21C-XF17C-G0-P2	19-15	4TL-F6372-00	29-6	5LW-14994-00	7-24	90110-06304	1-21	90201-05036	36-4
21C-H3311-00	35-18	21C-XF17C-H0-P3	19-15	4UU-F811G-00	25-3	5MX-E2213-01	4-14	90110-06846	1-26	90201-05036	38-7
21C-H3311-00	35-26	21C-XF17C-J0-P3	19-15	54B-14985-00	7-12	5TP-H1801-00	34-2	90111-05002	24-6	90201-06037	4-16
21C-H331E-00	35-4	21C-XF17D-40-P2	23-11	54B-E1111-00	1-1	5TS-F413B-00	24-13	90111-05003	24-5	90201-06055	19-20
21C-H3320-00	35-9	21C-XF17D-60-P4	23-11	54B-E1111-10	1-1	5TS-F836B-02	19-16	90111-05808	5-2	90201-06078	18-21
21C-H332E-00	35-12	21C-XF17D-E0-P7	23-11	54B-E1169-00	1-7	5US-25852-00	30-7	90111-06087	8-6	90201-060A3	20-11
21C-H3330-00	35-17	21C-XF17D-F0-P8	23-11	54B-E1181-00	1-19	5US-25854-00	30-6	90111-06807	8-7	90201-060A3	23-8
21C-H3340-00	35-25	21C-XF412-0A-33	24-1	54B-E1186-00	1-13	5US-F3485-00	36-6	90111-06829	37-16	90201-061A5	17-14
21C-H334E-00	35-28	21C-XF412-T0-33	24-1	54B-E1310-00	1-22	5US-F5321-10	28-6	90111-06830	37-15	90201-06726	18-5
21C-H3350-00	41-13	21C-XF412-U0-P5	24-1	54B-E1454-00	2-14	5US-F5744-00	27-8	90111-06831	36-13	90201-06871	16-13
21C-H3371-00	41-14	21C-XF412-V0-P4	24-1	54B-E1476-00	2-19	5US-F5827-00	27-9	90111-06847	27-2	90201-08612	8-13
21C-H3500-60	36-1	21C-XF413-0A-33	24-2	54B-E1536-00	2-12	5US-F5977-00	27-5	90116-08834	28-20	90201-087F0	8-17
21C-H355M-00	35-20	21C-XF413-T0-33	24-2	54B-E2111-00	3-1	5US-H5110-00	41-18	90119-05022	41-17	90201-08834	39-10

21CE

PART NO	REF. NO.	PART NO	REF. NO.	PART NO	REF. NO.	PART NO	REF. NO.	PART NO	REF. NO.	PART NO	REF. NO.
90201-08866	31-16	90387-068D4	37-7	90506-26807	31-28	93210-19809	10-23	95027-06016	4-18	95812-08035	17-6
90201-08866	31-38	90387-068E8	37-17	90506-35816	32-3	93210-29807	34-7	95027-06020	5-8	95812-08035	31-14
90201-08871	25-18	90387-068M3	23-6	90508-183B9	31-3	93210-30611	6-3	95027-06020	40-2	95812-08035	31-36
90201-101J1	32-20	90387-068S1	20-15	90508-32805	16-5	93210-32814	10-11	95027-06040	10-6	95812-10080	17-3
90201-105E8	12-3	90387-08822	17-17	91312-05008	41-8	93306-002X2	4-3	95027-06040	10-21	95817-08040	8-16
90201-10815	30-3	90387-10003	32-19	91312-06016	33-4	93306-002Y1	4-3	95027-06045	9-7	95817-10130	17-9
90201-10841	31-10	90387-107H6	23-7	91312-06020	12-9	93306-054Y5	28-16	95027-06050	10-7	95822-06030	23-9
90201-10841	31-30	90387-10822	32-2	91312-06020	34-6	93306-054Y6	14-2	95027-06055	9-6	95827-06012	6-36
90201-12019	13-4	90387-12845	20-18	91312-06030	33-3	93306-054YA	28-16	95027-06065	5-9	95827-06012	23-34
90201-12030	20-8	90387-155J0	2-21	91317-05010	1-8	93306-054YE	14-2	95027-06070	9-8	95827-06016	6-24
90201-12030	20-22	90387-20813	2-13	91317-05016	3-12	93306-201Y4	14-3	95302-08600	28-29	97012-06014	18-9
90201-122H1	33-6	90401-10818	30-2	91317-06014	10-2	93306-203XR	14-17	95302-08600	28-40	97012-06020	16-14
90201-15022	2-17	90430-06014	1-3	91317-06016	6-30	93306-252XG	26-4	95302-08700	28-26	97022-06020	18-4
90201-15837	28-35	90430-06014	1-16	91317-06016	11-14	93306-252XG	28-3	95307-06600	18-20	97027-06025	20-12
90201-162H4	11-10	90430-10148	41-4	91317-06018	4-15	93306-252YG	2-22	95307-06600	28-13	97507-05512	36-7
90201-167P7	11-8	90430-12227	5-4	91317-06025	1-12	93306-252YH	26-4	95602-08200	28-21	9750M-06425	39-9
90201-177G4	11-16	90445-13806	32-17	91317-06025	1-15	93306-252YH	28-3	95602-10200	32-5	97602-05320	6-15
90201-177G4	14-14	90446-07805	40-5	91317-06025	6-6	93306-253Y6	2-23	95602-14200	26-9	97702-40030	38-5
90201-20685	11-4	90450-44803	6-4	91401-20012	16-11	93306-272X1	14-18	95602-14200	28-34	97702-50012	19-4
90201-22018	21-12	90450-50802	6-21	91401-20012	28-27	93306-272X4	14-18	95612-12100	20-7	97702-50012	19-8
90201-22793	14-8	90464-11014	6-38	91401-20012	32-8	93306-305YR	2-6	95612-12100	20-21	97702-50012	19-14
90201-25290	12-7	90464-14803	36-9	91401-25015	31-5	93310-325X3	12-6	95617-08620	1-4	97702-50012	24-14
90202-05180	24-7	90464-16016	6-39	91401-25015	31-21	93310-628X0	2-3	95702-05500	41-19	97702-50014	18-23
90202-05807	8-8	90464-16061	40-17	91401-25015	32-27	93315-112Y9	13-26	95702-06500	17-15	97702-50025	38-6
90202-05807	23-26	90464-80802	23-5	91701-08035	32-26	93317-318Y5	20-4	95702-06500	40-10	97707-40014	37-11
90202-05807	40-13	90464-80802	40-18	91701-08040	31-4	93410-20038	11-5	95707-06300	39-8	97707-50014	36-3
90202-26142	21-9	90467-08808	6-9	91701-08040	31-20	93410-22039	14-9	95707-08500	8-12	98502-05012	7-11
90208-20003	13-21	90467-100A3	23-28	91810-14804	1-20	93450-16812	2-10	95707-12500	33-5	98502-05014	31-7
90208-20005	11-3	90467-12800	6-17	91830-21014	9-4	93501-04805	32-29	95802-06010	31-26	98502-05014	31-23
90209-18208	14-12	90467-13816	6-26	91830-21014	10-5	93505-16844	13-25	95802-06012	23-31	98502-06016	19-19
90214-10006	2-18	90467-15012	6-33	91830-21014	10-20	93605-06800	4-2	95802-06012	24-18	98507-04008	7-15
90215-10284	2-25	90467-16805	6-27	92902-06200	16-12	93608-43238	16-7	95802-06012	41-15	98507-05012	29-4
90240-06804	32-10	90467-16805	6-34	92902-06200	32-9	93612-16254	1-10	95802-06020	4-12	98517-06012	14-5
90249-12008	32-13	90480-01559	19-21	92902-06200	32-11	93822-14800	14-20	95802-06025	17-13	98706-04012	30-8
90269-06008	19-17	90480-08801	18-3	92902-08200	28-30	93900-00824	26-6	95802-06025	37-8	99001-10600	16-6
90280-03017	2-7	90480-12581	8-4	92902-08600	28-39	93900-00824	28-23	95807-06012	30-16	99009-10400	12-4
90282-05031	2-24	90480-12812	10-16	92902-14200	26-10	94110-17804	26-5	95807-06014	21-18	99009-16400	11-9
90338-05801	9-5	90480-12816	24-16	92907-06600	6-5	94114-17800	28-22	95807-06016	17-12	99009-17400	11-17
90340-12097	5-3	90480-13398	24-4	93101-10838	10-24	94568-B5128	28-36	95807-06020	10-14	99009-20500	13-28
90340-14824	10-8	90480-14101	37-6	93102-12875	16-8	94568-G2096	4-8	95807-08025	8-14		
90340-32823	10-10	90480-14819	38-8	93102-12877	13-27	94703-00885	1-18	95807-08035	8-15		
90387-06023	8-5	90480-14822	36-2	93102-22818	14-19	95022-06010	25-5	95812-06014	31-13		
90387-06048	18-10	90480-16804	36-12	93106-22808	26-3	95022-06012	1-2	95812-06014	31-33		
90387-06048	23-33	90501-06800	15-7	93106-22808	28-4	95022-08025	25-17	95812-06014	31-35		
90387-06048	40-12	90501-10245	32-12	93106-26801	28-18	95022-08040	21-11	95812-06025	40-11		
90387-066J9	20-10	90501-12743	32-28	93109-18803	20-3	95022-10025	32-23	95812-08016	17-7		
90387-06737	6-23	90506-12001	28-8	93109-20821	11-20	95024-08035	21-15	95812-08025	31-15		
90387-068C5	18-2	90506-15001	28-9	93210-12800	1-9	95027-06010	14-22	95812-08025	31-37		
90387-068C9	10-15	90506-23807	32-16	93210-14899	10-9	95027-06014	20-16				

COPYRIGHT: All rights reserved. No part of this publication
may be reproduced without permission.



INDIA YAMAHA MOTOR PVT. LIMITED

19/6 Mathura Road, Faridabad - 121 006, INDIA

1Y11-(PC-01)-052-03-12-E
PRINTED IN INDIA