

We have pleasure in presenting the Spare Parts Catalogue for 'BM-100' Motorcycle. This catalogue has been specially designed to assist you in selecting the correct parts for procurement to maintain 100% availability.

The Bajaj spares are subjected to the stringent quality control standards to ensure longer life of the vehicle. It is therefore necessary that only the Genuine Bajaj Spares are used.

In a continual effort to improve Performance and Efficiency of the vehicles, Specifications, Diagrams, Illustrations and Part Numbers can change without notice. Consequently, the description in this Spare Parts Catalogue cannot therefore be final and binding on us.

The modifications / alterations which are carried out after the issue of this catalogue, will be conveyed to you through our Service Circulars. You are requested to make necessary corrections in the Parts Catalogue as per the circulars so as to keep your catalogue up-to-date. This will ensure the appropriate and speedy delivery of the Spare Parts as the order placed will bear the latest part numbers.

In case, if you need any technical assistance contact the concerned Regional Team or write to us on the following address :

**Bajaj Auto Limited**  
International Marketing  
Akurdi, Pune 411 035 India  
Phone : 020-27472851  
Fax : 020-27407395  
E-mail : [exports@bajajauto.co.in](mailto:exports@bajajauto.co.in)

All information contained in this manual is based on the latest product information at the time of publication. Bajaj Auto Limited accepts no liability for any inaccuracies or omissions in this publication, although every possible care has been taken to make it as complete and accurate as possible. All procedures and specifications subject to change without prior notice. The right is reserved to make such changes at any time without prior notice and without incurring an obligation to make such changes to product manufactured previously. Contact your authorized Bajaj Dealer for the latest information on product improvements incorporated after this manual was issued.

DOC. NO.: 71111489

REV. 00, Mar.2012

## Instructions for using the Catalogue



1. How to Read the Catalogue : Open the catalogue and from the pictorial index locate the group in which the part you want to find is present. Turn over to the concerned page number (as given by pictorial index). Now find out the figure of the part you wish to order. Write down the part number against that particular figure number from the text.

In case, if you have the part number and you need the other details, the part index can be used. The part index (at the end of the catalogue) will give you the figure and page number of the part you wish to order.

2. How to Order Spare Parts : The part number and the description of the part required should be invariably mentioned in the order as per the catalogue text.

The latest part number as conveyed through our service circulars should only appear on the order. In case of ordering painted components, colour shade of the components should be mentioned.

The quantity shown against the part number is the quantity per vehicle for that group so that particular quantity should be multiplied by the number of sets required.

3. Part Number System: We have used 8 digit system for part numbers. The model or hardware item is indicated by first two digits or alphanumeric, the next two or four digits indicate main group and the last four or two digits indicate serial number in main group or serial number or subgroup of fastener respectively. Thus the part numbers will be indicated by 2-2-4 or 2-4-2 digit system. Understanding this system will enable you to identify the spare parts easily.

4. Abbreviations : The following abbreviations are used in this catalogue.

assly.	Assembly	V	Volts
N.I.	Not illustrated	W	Watts
C'case	Crankcase	accl.	Accelerator
Cyl	Cylinder	Comp.	Complete
o/s.	Over size	Fr	Front
Std.	Standard	L	Length
A/t.	Alternate	Rr	Rear
R.H.	Right hand	Hex.	Hexagonal
L.H.	Left hand	AR	As required

## Index



No.	Description	Page No.
1	Cylinder head	1
2	Valve	2
3	Camshaft & Tensioner	3
4	Cylinder & piston	4
5	Crank shaft	5
6	Transmission	6
7	Change drum / Shift fork	7
8	Gear change mechanism	8
9	Crankcase RH / Engine assly.	9
10	Crankcase LH	10
11	Pipe Oil	11
12	Cover Magneto	12
13	Clutch Cover	13
14	Clutch	14
15	Kick starter Mechanism	15
16	Carburettor	16
17	Air Filter Assly. & Battery Box	17
18	Muffler	18
19	Oil pump	19
20	Magneto assly	20
21	Frame	21
22	Swing arm / Rear shock absorber	22
23	Stand, Step & Stay LH / RH	23
24	Fender (Front & Rear)	24
25	Wheel Rim/Spokes/Tyre/Tube	25
26	Front Hub	27&28
27	Rear Hub	29to32
28	Brake pedal	33
29	Handle bar	34&35
30	Front Fork	36&37
31	Painted Parts	38&39
32	Fuel Tank Cap, Tap Assly. & Fuel Gauge	40
33	Chain case	41
34	Fittings-Petrol tank & Side cover	42
35	Meter Assly.	43
36	Control Cables	44
37	Head Lamp Assly.	45

No.	Description	Page No.
38	Turn Signal Lamp	46
39	Front & Rear Number Plate	47
40	Tail Lamp Assly.	48
41	Electrical Equipment	49
42	Tool kit	50
43	Seat Assly.	51
44	Accessories	52
45	Kit List	53&54
46	Added Deleted Part List	55&56
47	Part Index	57

PLATE NO. : 1  
CYLINDER HEAD

PAGE NO.:  
1

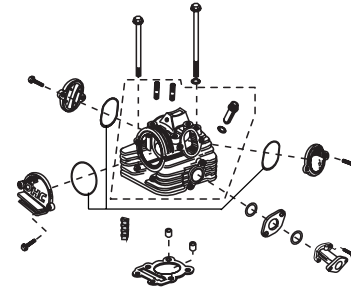

PLATE NO. : 3  
CAMSHAFT / TENSIONER

PAGE NO.:  
3

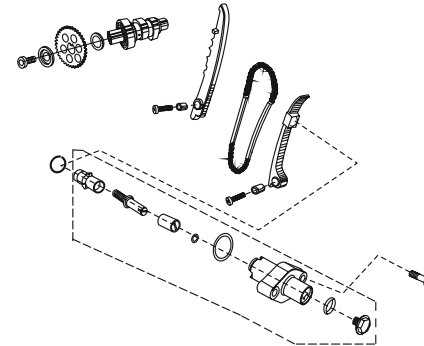

PLATE NO. : 5  
CRANKSHAFT

PAGE NO.:  
5

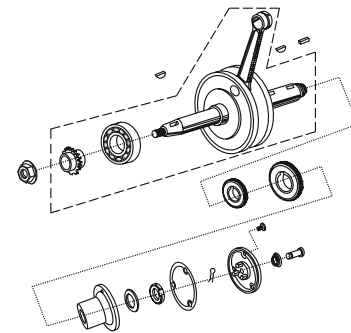

PLATE NO. : 2  
VALVE

PAGE NO.:  
2

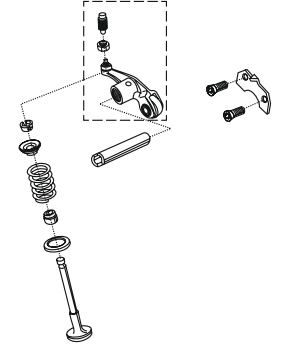

PLATE NO. : 4  
CYLINDER AND PISTON

PAGE NO.:  
4

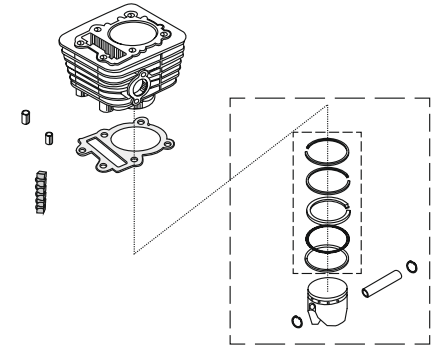
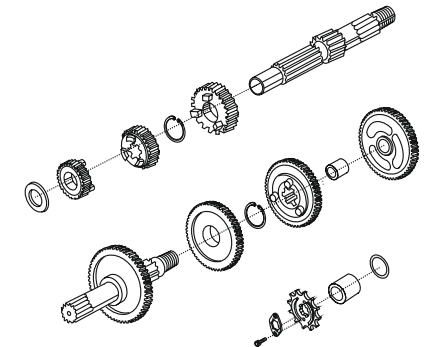

PLATE NO. : 6  
TRANSMISSION

PAGE NO.:  
6



# Pictorial Index

**BOXER**  
E160 100

PLATE NO. : 7  
CHANGE DRUM / SHIFT FORK

PAGE NO.:  
7

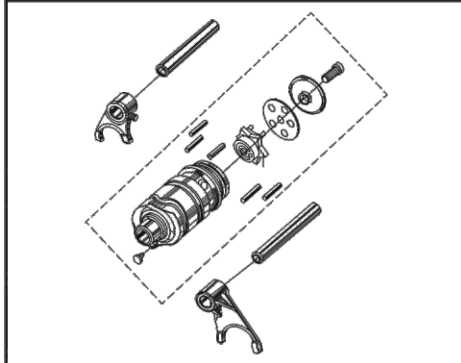

PLATE NO. : 9  
CRANKCASE RH / ENGINE ASSLY.

PAGE NO.:  
9

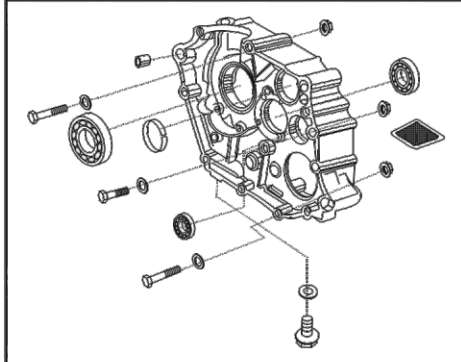

PLATE NO. : 11  
PIPE OIL

PAGE NO.:  
11

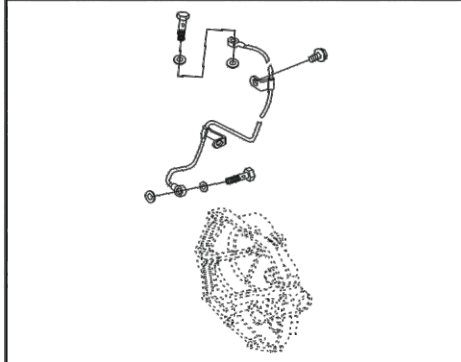

PLATE NO. : 8  
GEAR CHANGE MECHANISM

PAGE NO.:  
8

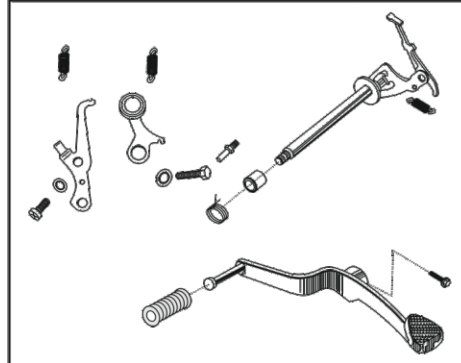

PLATE NO. : 10  
CRANKCASE LH

PAGE NO.:  
10

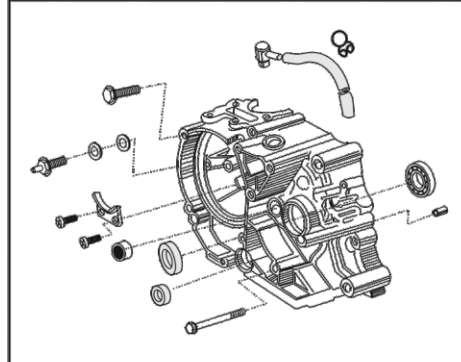
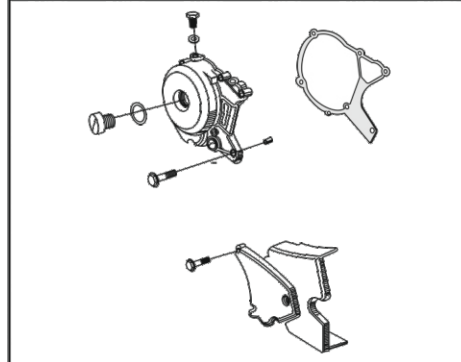

PLATE NO. : 12  
COVER GENERATOR AND COVER CHAIN

PAGE NO.:  
12



# Pictorial Index

**BOXER**  
E160 100

PLATE NO. : 13  
CLUTCH COVER

PAGE NO.:  
13

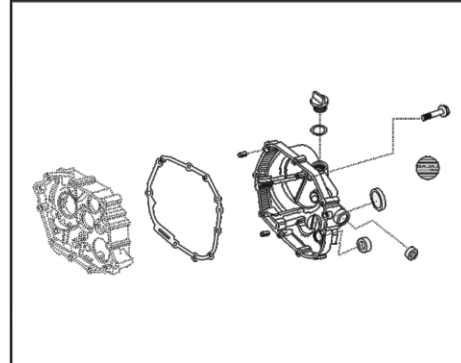

PLATE NO. : 15  
KICK STARTER MECHANISM

PAGE NO.:  
15

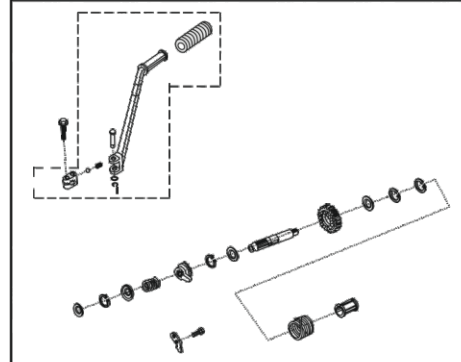

PLATE NO. : 17  
AIR FILTER ASSLY. AND BATTERY BOX

PAGE NO.:  
17

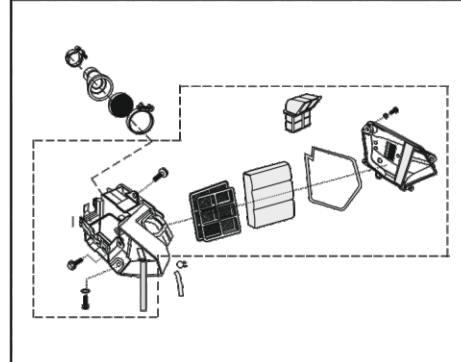

PLATE NO. : 14  
CLUTCH

PAGE NO.:  
14

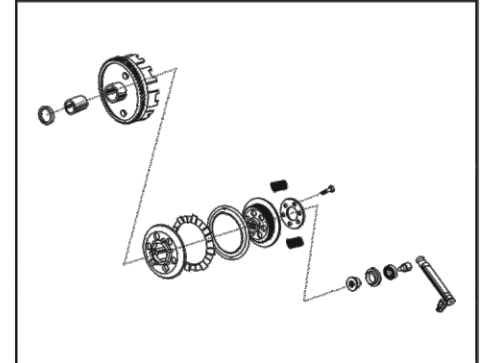

PLATE NO. : 16  
CARBURETTOR

PAGE NO.:  
16

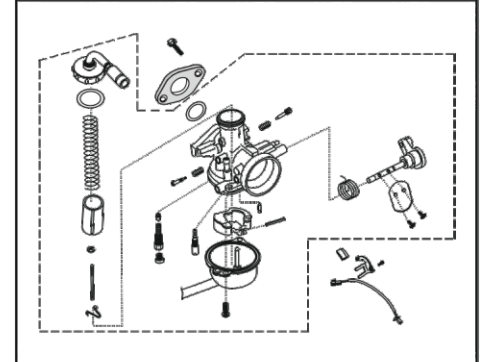
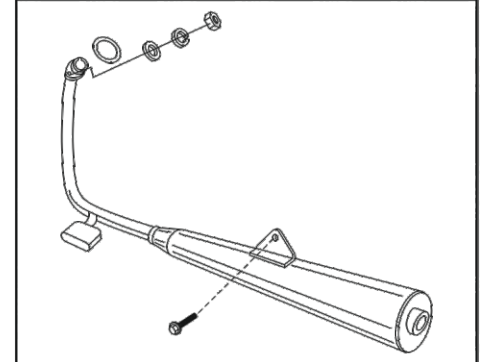

PLATE NO. : 18  
MUFFLER

PAGE NO.:  
18





# Pictorial Index

**BOXER**  
100 100

PLATE NO. : 19  
OIL PUMP

PAGE NO.:  
19

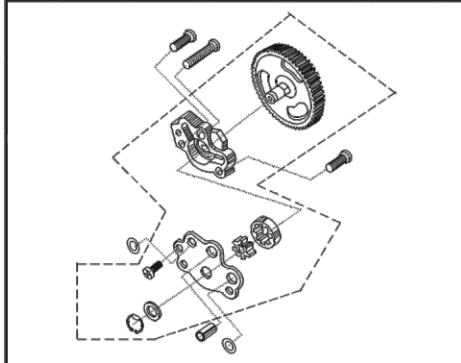

PLATE NO. : 21  
FRAME

PAGE NO.:  
21

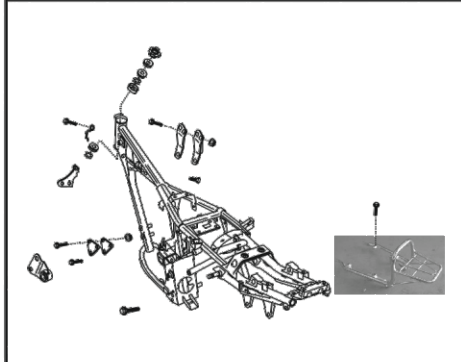

PLATE NO. : 23  
STAND, STEP AND STAY LH / RH

PAGE NO.:  
23

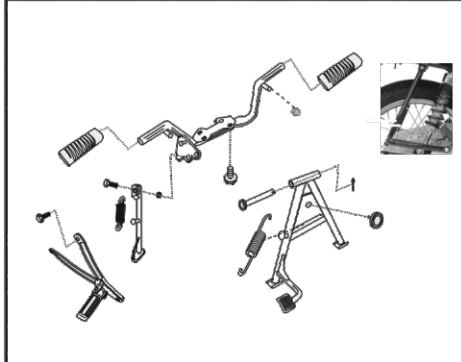

PLATE NO. : 20  
MAGNETO ASSLY.

PAGE NO.:  
20

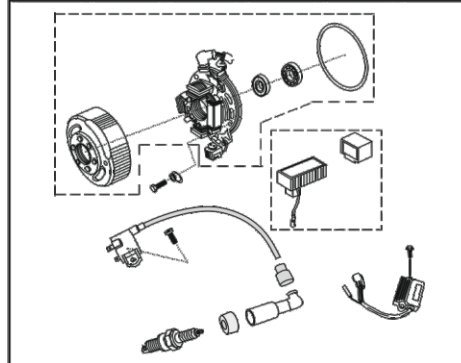

PLATE NO. : 22  
SWING ARM / REAR SHOCK ABSORBER

PAGE NO.:  
22

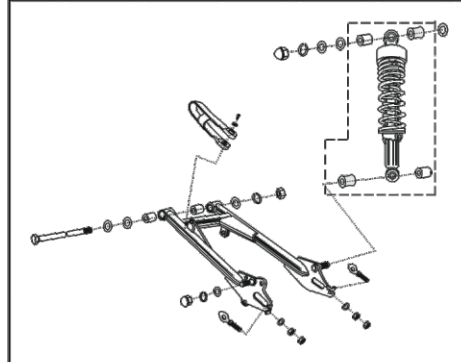
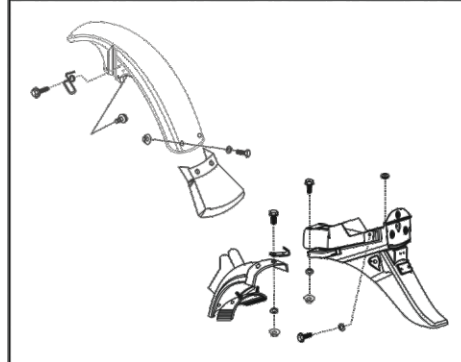

PLATE NO. : 24  
FENDER - FRONT & REAR

PAGE NO.:  
24



# Pictorial Index

**BOXER**  
100 100

PLATE NO. : 25  
WHEEL RIM / SPOKES / TYRE / TUBE

PAGE NO.:  
25&26

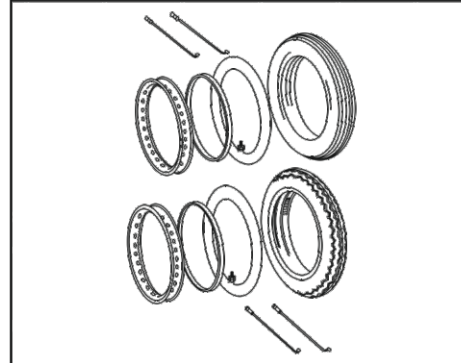

PLATE NO. : 27  
REAR HUB

PAGE NO.:  
29 & 32

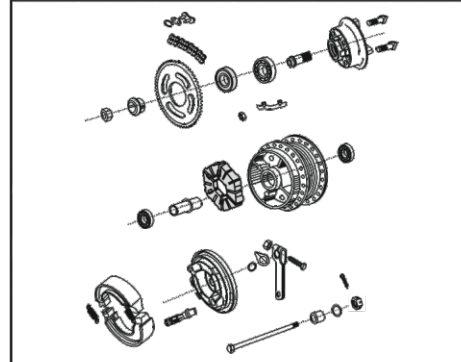

PLATE NO. : 29  
HANDLE BAR

PAGE NO.:  
34 & 35

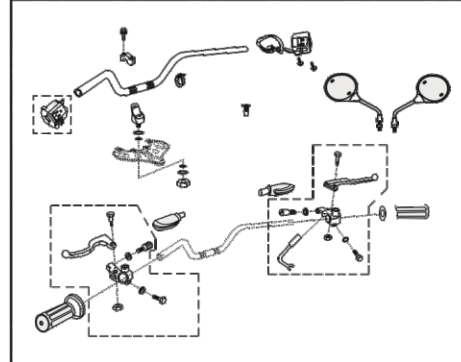

PLATE NO. : 26  
FRONT HUB

PAGE NO.:  
27 & 28

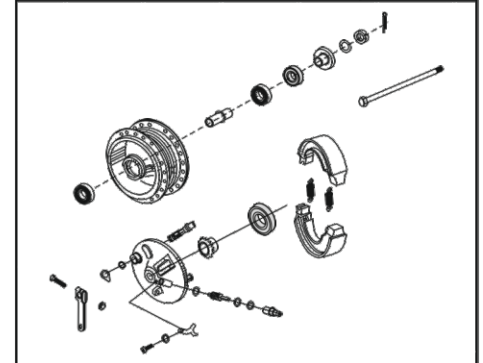

PLATE NO. : 28  
BRAKE PEDAL

PAGE NO.:  
33

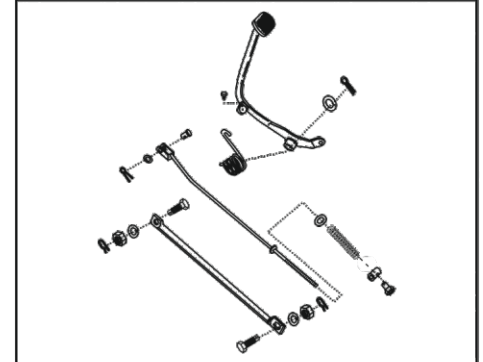
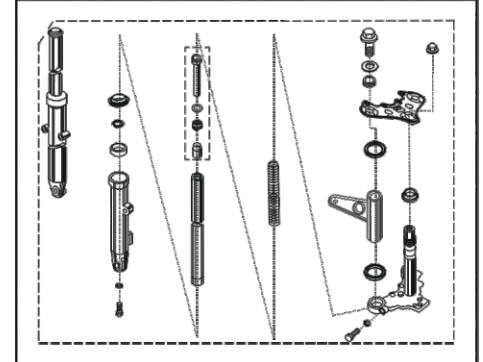

PLATE NO. : 30  
FRONT FORK

PAGE NO.:  
36 & 37



# Pictorial Index

**BOXER**  
EM 100

PLATE NO. : 31  
PAINTED PARTS

PAGE NO.:  
38 & 39

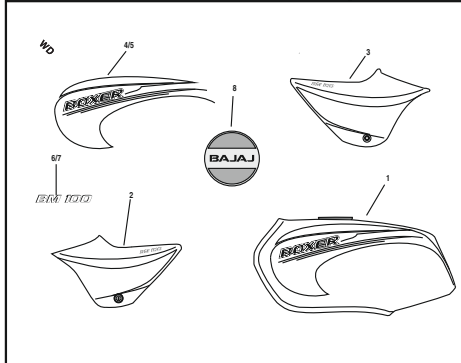

PLATE NO. : 33  
CHAIN CASE

PAGE NO.:  
41

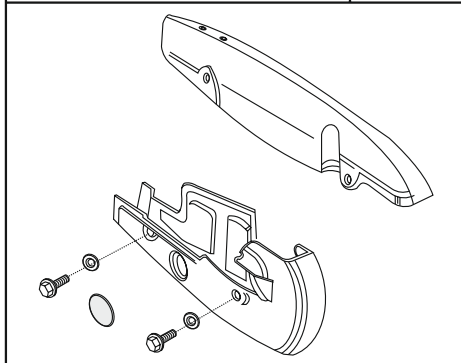

PLATE NO. : 35  
METER ASSLY.

PAGE NO.:  
43

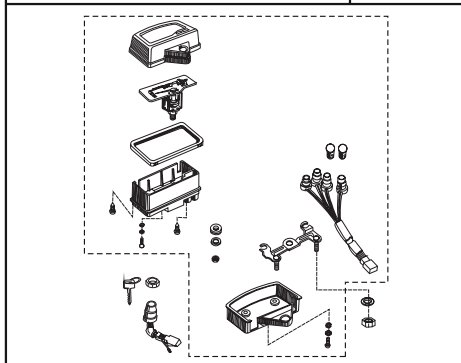

PLATE NO. : 32  
MAGNETO ASSLY.

PAGE NO.:  
40

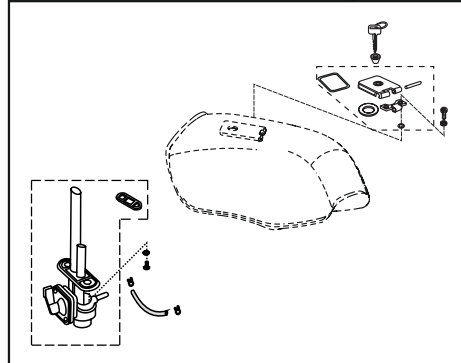

PLATE NO. : 34  
FITTINGS-PETROL TANK & SIDE COVER

PAGE NO.:  
42

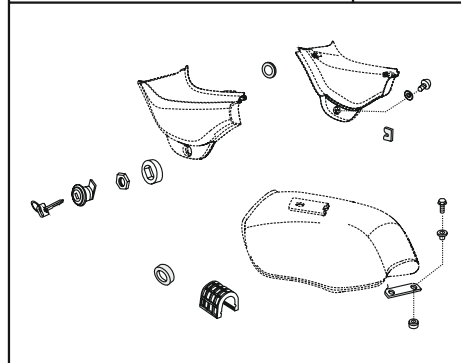
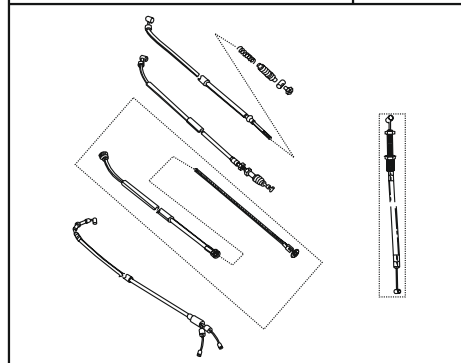

PLATE NO. : 36  
CONTROL CABLES

PAGE NO.:  
44



# Pictorial Index

**BOXER**  
EM 100

PLATE NO. : 37  
HEAD LAMP ASSLY.

PAGE NO.:  
45

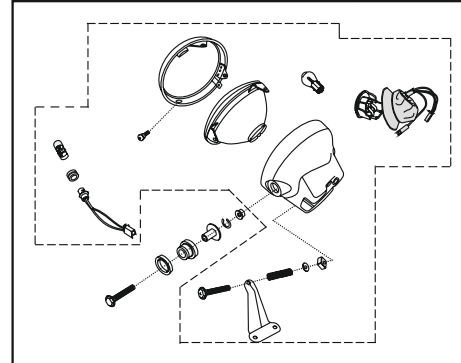

PLATE NO. : 39  
FRONT AND REAR NUMBER PLATE

PAGE NO.:  
47

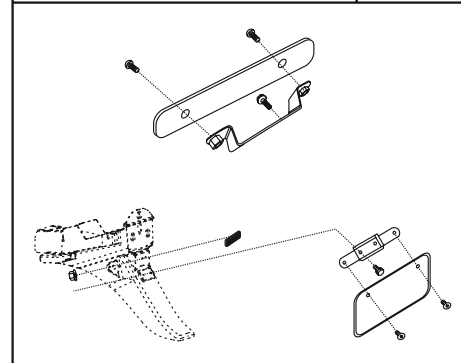

PLATE NO. : 41  
ELECTRICAL EQUIPMENT

PAGE NO.:  
49

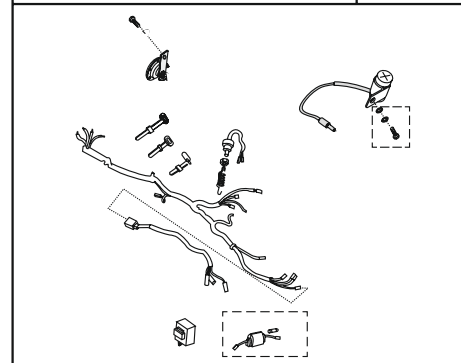

PLATE NO. : 38  
TURN SIGNAL LAMP

PAGE NO.:  
46

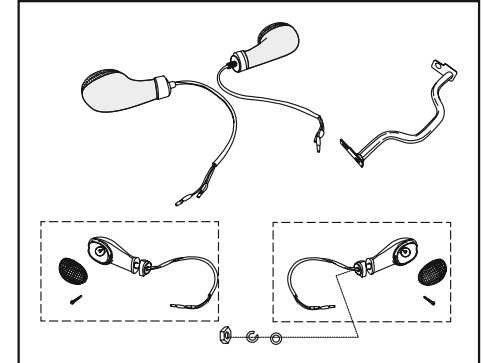

PLATE NO. : 40  
TURN SIGNAL LAMP

PAGE NO.:  
48

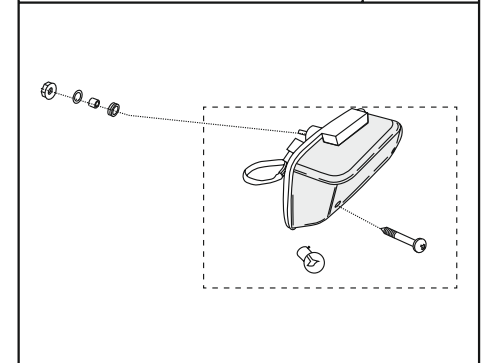

PLATE NO. : 42  
TOOL KIT

PAGE NO.:  
50

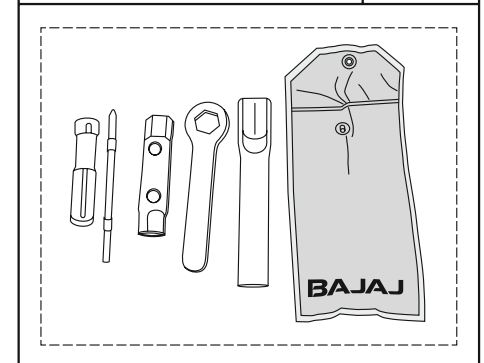



PLATE NO. : 43	PAGE NO.:
SEAT ASSLY	51
	

PLATE NO. : 44	PAGE NO.:
ACCESSORIES	52
	



No.	Part No.	Description	Qty/ Veh.	Remarks
1	36 DU10 01	O Ring Kit	1	Ref. Page No. 50
2	31 1010 06	Cap	2	
3	39 1673 04	Flanged bolt	6	
4	31 1010 08	Guide Valve	2	
5	39 1021 21	O Ring	2	
6	DD 1013 47	Bolt	2	
7	DD 1013 50	Stud	2	
8	DD 1013 49	Bolt	4	
9	DU 1012 08	Head Comp. Cylinder	1	
10	31 1010 07	Cover (OHC)	1	
11	DU 1012 28	Bolt	2	
12	39 1000 06	Hollow Dowel Pin	2	
13	DD 1013 43	Gasket head	1	
14	39 1017 21	O Ring	2	
15	DD 1014 81	Damper Cylinder Head	4	
16	31 1011 75	Insulator (Head Side)	1	
17	DU 1010 58	Pipe Intake	1	
18	DD 1015 21	Plain washer	4	

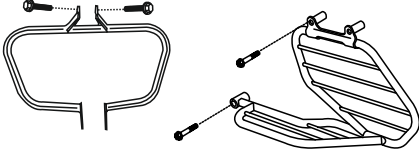
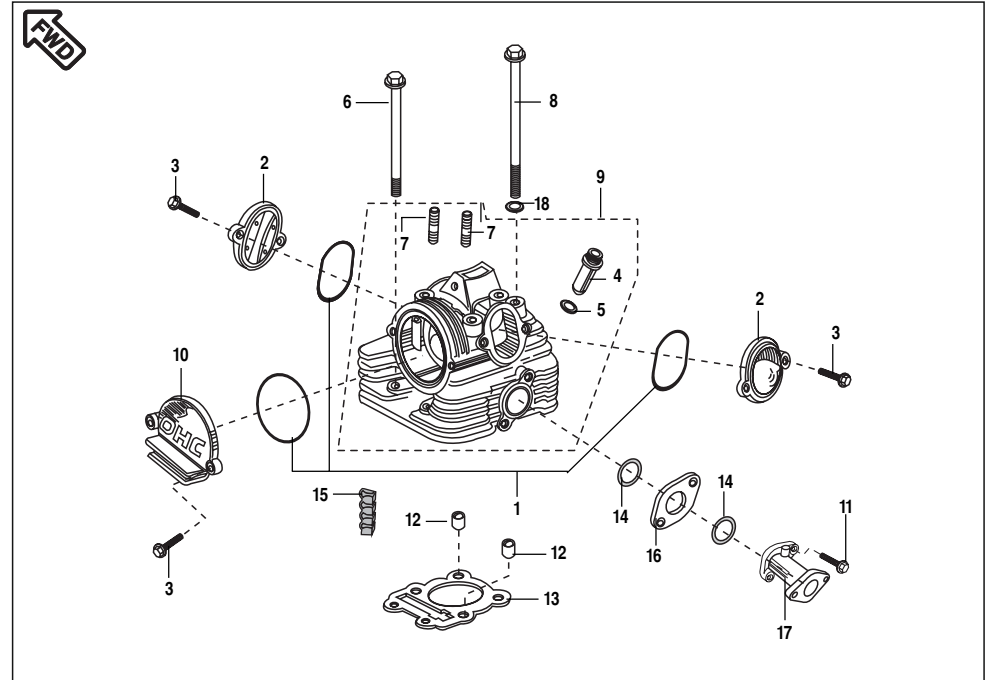
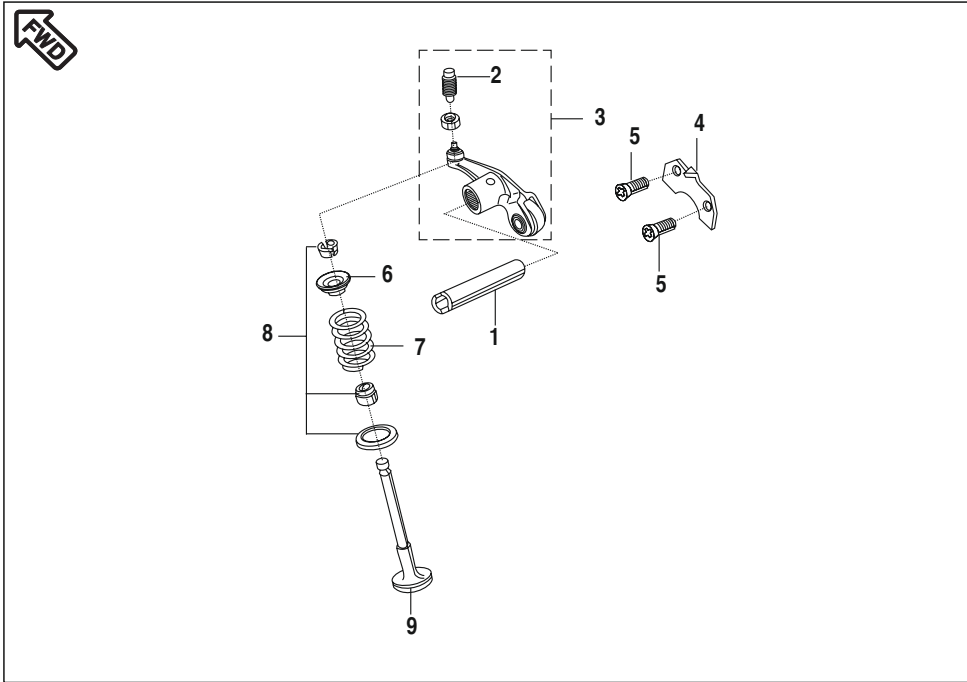

No.	Part No.	Description	Qty/ Veh.	Remarks
1	DU 1011 91	Shaft Rocker	2	
2	DF 1010 55	Screw	2	
3	DU 1011 90	Rocker arm assembly	2	
4	31 1011 04	Stopper	1	N.S
5	39 0702 01	Screw Pan Cros	2	
6	31 1010 18	Retainer Valve Spring	2	
7	DD 1014 40	Spring Stiffer	2	
8	36 3110 08	Collet Seal Oil Kit	1	Ref. Page No. 50
9	36 3110 28	Valve Kit	1	Ref. Page No. 50

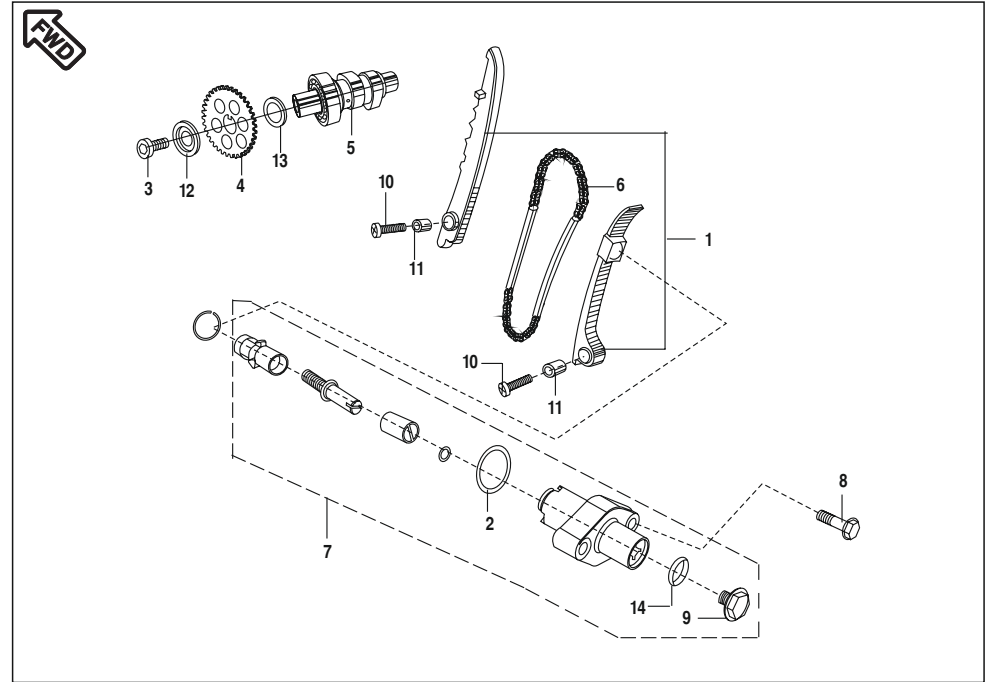

No.	Part No.	Description	Qty/ Veh.	Remarks
1	36 3110 06	Chain Guide Kit	1	Ref. Page No. 50
2	39 1017 21	O Ring	1	
3	DU 1012 25	Hex. Soc. HD Screw	1	
4	DU 1010 56	Sprocket (28 T)	1	
5	DZ 1010 75	Camshaft Assly	1	New
6	31 1010 33	Chain	1	
7	DD 1014 07	Tensioner Assly. / O ring	1	
8	LA D000 26	Bolt Flanged Small	2	
9	DD 1010 62	Bolt	1	
10	39 0748 01	Screw Pan Cross	2	
11	39 0999 06	Hollow Dowel Pin	2	
12	DU 1010 66	Washer Spl. Cam Shaft	1	
13	DU 1010 67	Collar Cam	1	
14	39 1790 21	O Ring	1	

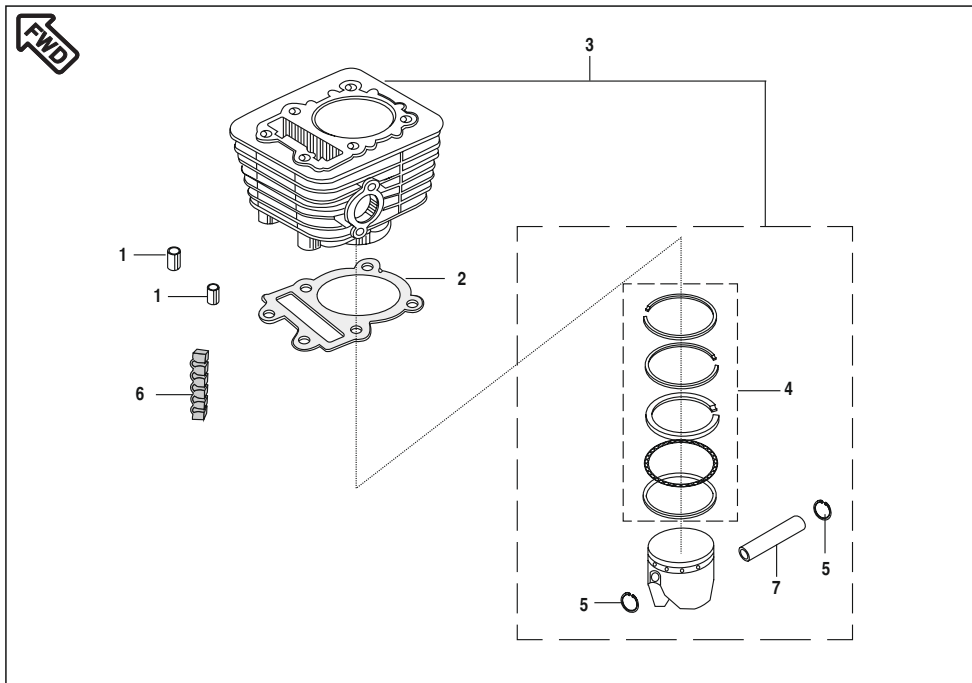

No.	Part No.	Description	Qty/ Veh.	Remarks
1	39 1000 06	Hollow dowel Pin	2	
2	DD 1010 07	Gasket - Cyl. Block	1	
3	DU 1012 18	Cylinder Block Piston assly	1	
4	36 DD40 01	Kit Piston ring set std.	1	
5	39 0985 17	Wire Clip	2	
6	DH 1014 30	Damper	3	

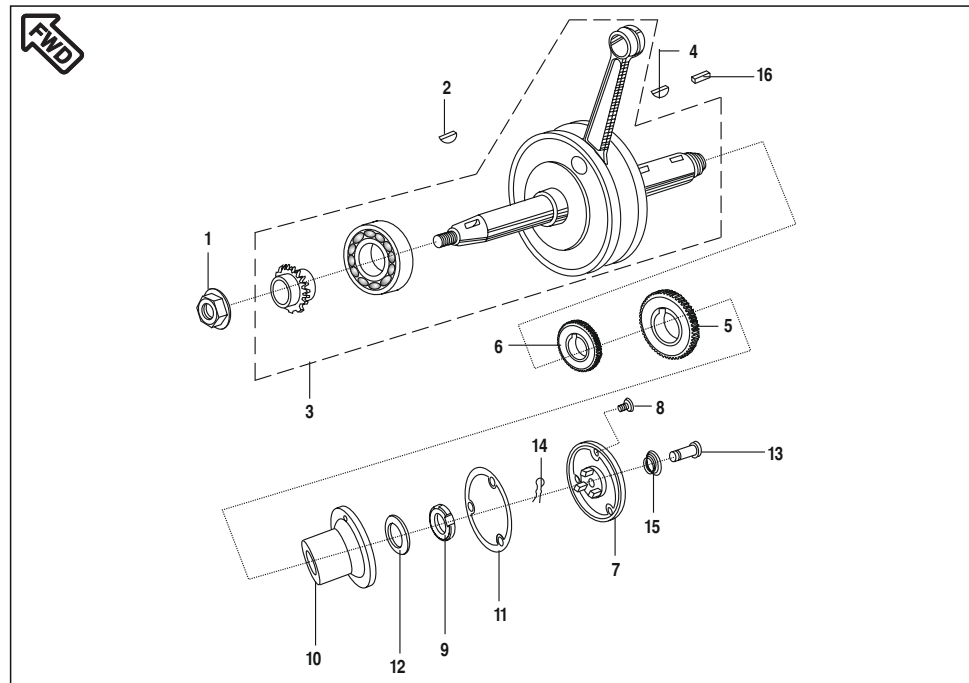

No.	Part No.	Description	Qty/ Veh.	Remarks
1	39 1055 15	Nut	1	
2	01 1006 10	Woodruff Key	1	
3	DU 1010 05	Crankshaft Assly.	1	
4	28 1011 07	Key Woodruff	2	
5	DX 1010 47	Gear Primary, Helical (23 T)	1	
6	FA 1013 34	Gear	1	
7	DU 1010 41	Cover	1	
8	39 1699 01	Countersunk Screw	3	
9	DH 1011 95	Nut	1	
10	DX 1010 53	Body Centrifugal Oil Filter(C.I.)	1	
11	DU 1010 10	Gasket Central Oil Filter	1	
12	39 2200 11	Washer	1	
13	DH 1010 66	Joint Oil Delivery	1	
14	39 2199 08	Pin Snap	1	
15	DH 1010 67	Spring Oil Delivery	1	
16	28 1011 07	Key Woodruff	1	Alt. DU 1012 11

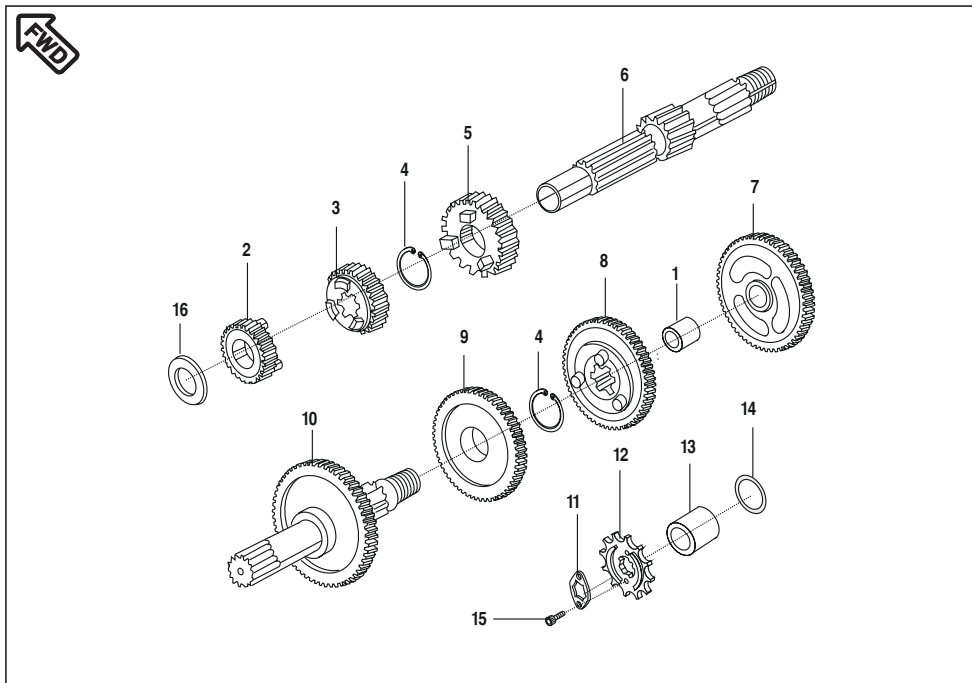

No.	Part No.	Description	Qty/ Veh.	Remarks
1	DD 1013 09	Bushing Floating	1	
2	DX 1010 45	Gear 2nd Input	1	
	DU 1012 79	Gear 2nd Input	1	Ref. Cir. IB-181
3	DX 1010 48	Gear Transmission Spur(3rd)	1	
4	39 0987 17	Ring Snap (16 mm)	2	
5	DX 1010 49	Gear 4th Input	1	
6	DU 1010 11	Shaft Transmission Input	1	
	DU 1012 78	Shaft Transmission Input	1	Ref. Cir. IB-181
7	DU 1010 80	Gear 1st Output	1	
8	DX 1010 51	Gear 4th Output	1	
9	DX 1010 50	Gear Transmission Spur(3rd)	1	
10	DX 1010 46	Shaft Transmission Output	1	
11	DU 1012 13	Plate For Sprocket Output	1	
12	DM 1011 14	Sprocket Output (110 mm Drum)	1	For Kit 36 DU15 05
	DX 1010 52	Sprocket Output (130 mm Drum)	1	For Kit 36 DM00 01
13	DP 1011 55	Collar (Sintered)	1	
14	DP 1011 68	'O' Ring	1	
15	39 1981 04	Bolt	2	

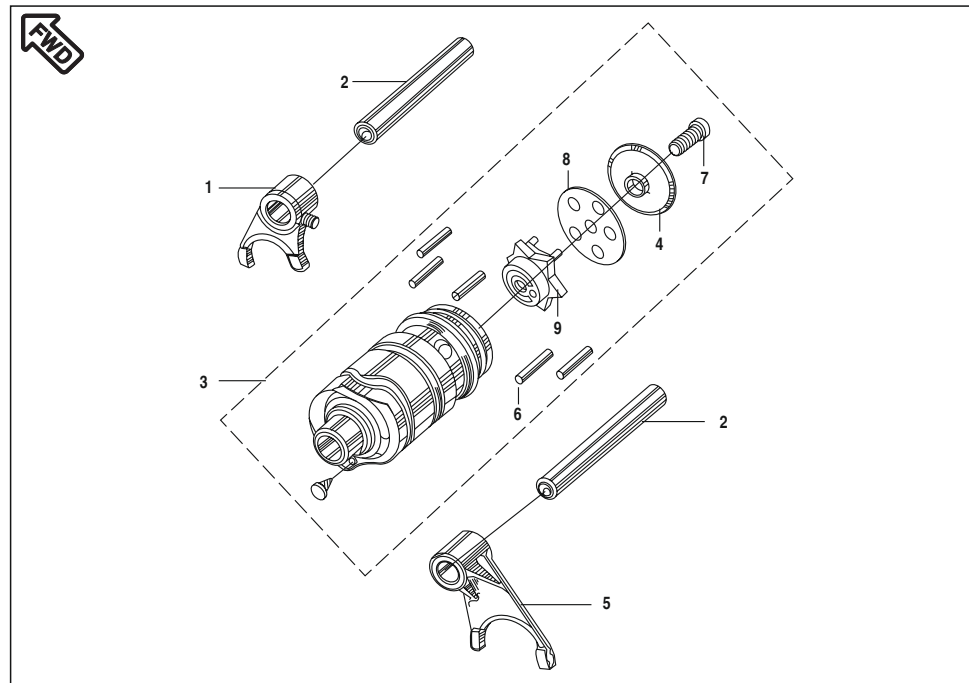

No.	Part No.	Description	Qty/ Veh.	Remarks
1	31 1011 91	Fork Shift	1	
2	31 1010 51	Rod shift	2	
3	DU 1010 81	Drum assly. change	1	
4	DM 1010 98	Cup Stopper	1	
5	31 10 1192	Fork shift	1	
6	39 0992 06	Pin Dowel	5	
7	DP 1013 40	Bolt Soc. Head	1	
8	DM 1010 99	Plate Spacer	1	
9	DU 1010 83	Cam Drum Change	1	

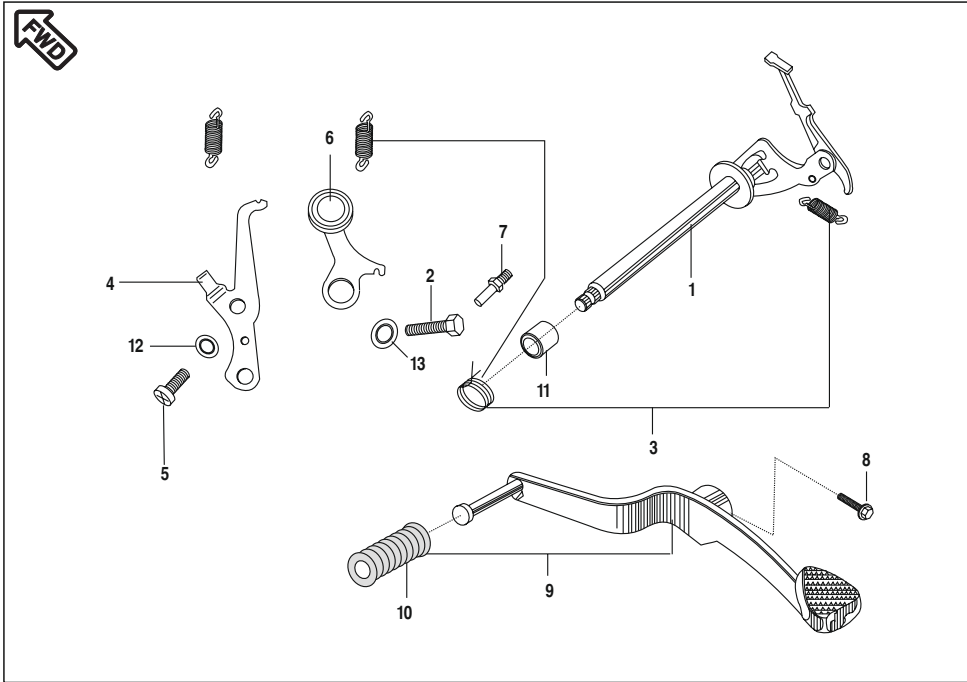

No.	Part No.	Description	Qty/ Veh.	Remarks
1	52 DU01 04	Lever Comp. Gear Shift Drum	1	Ref. Page No. 50
2	39 1994 04	Bolt	1	
3	36 DU10 04	Gear Lever Spring Kit	1	
4	DU 1010 74	Plate Position	1	
5	39 0746 01	Screw Pan Cross	1	
6	DU 1010 73	Stopper Comp. Gear Shift Drum	1	
7	DD 1011 06	Bolt	1	
8	39 2474 04	Flanged bolt	1	
9	DU 1011 85	Lever Change / Damper	1	
10	31 10 1108	Damper	1	
11	31 1011 09	Collar	1	
12	39 2704 11	Washer Spring Steel	1	
13	DU 1011 13	Spacer	1	

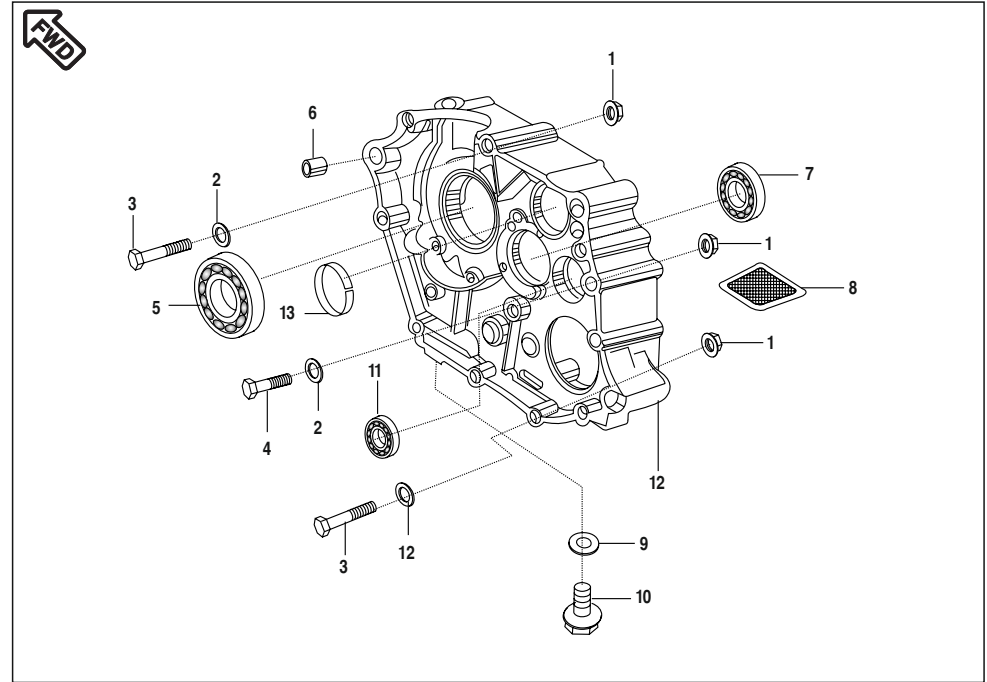

No.	Part No.	Description	Qty/ Veh.	Remarks
1	39 1225 15	Nut	3	N.S
2	39 0248 11	Plain Washer	3	
3	39 2702 04	Bolt	2	
4	39 1056 04	Bolt	1	
5	39 1864 20	Bearing Ball	1	
6	39 0999 06	Dowel Pin	5	N.I.
7	01 1701 11	Bearing	1	
8	DP 1014 52	Oil Strainer	1	
9	DG 1014 98	Gasket	1	
10	DU 1012 23	Plug (Drain)	1	
11	01 1701 10	Bearing	1	
12	DU 1010 75	Crankcase Comp. RH	1	
13	DU 1010 85	Bushing	1	
14	DU 1012 20	Engine Assembly	1	



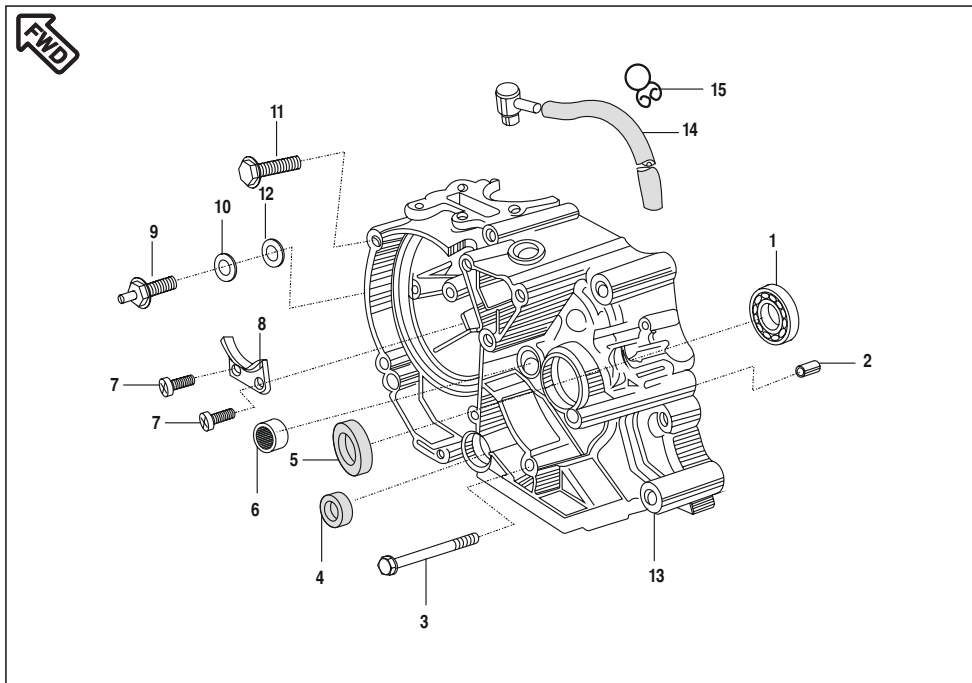

No.	Part No.	Description	Qty/ Veh.	Remarks
1	01 1701 11	Ball Bearing	1	
2	39 1050 06	Dowel Pin	1	
3	39 1066 04	Bolt Flanged Small	3	
4	39 1043 19	Oil Seal	1	
5	39 1080 19	Seal Oil	1	
6	39 1008 20	Bearing Needle	1	
7	39 0702 01	Screw Pan Cros	2	
8	31 1010 56	Guide	1	
9	31 2010 81	Switch Comp. (Neutral)	1	
10	39 0703 11	Plain Washer	1	N.S
11	39 1075 04	Bolt Flanged Small	7	
12	30 1010 15	Gasket	1	
	DG 1014 98	Gasket	1	
13	DD 1011 01	Crankcase LH	1	
	DU 1012 80	Crankcase LH	1	Ref. Cir. 181
14	DZ 1010 34	Tube rubber	1	
15	30 1410 15	Clamp	1	
	DK 1410 41	Clamp	1	Alternate for 30141015

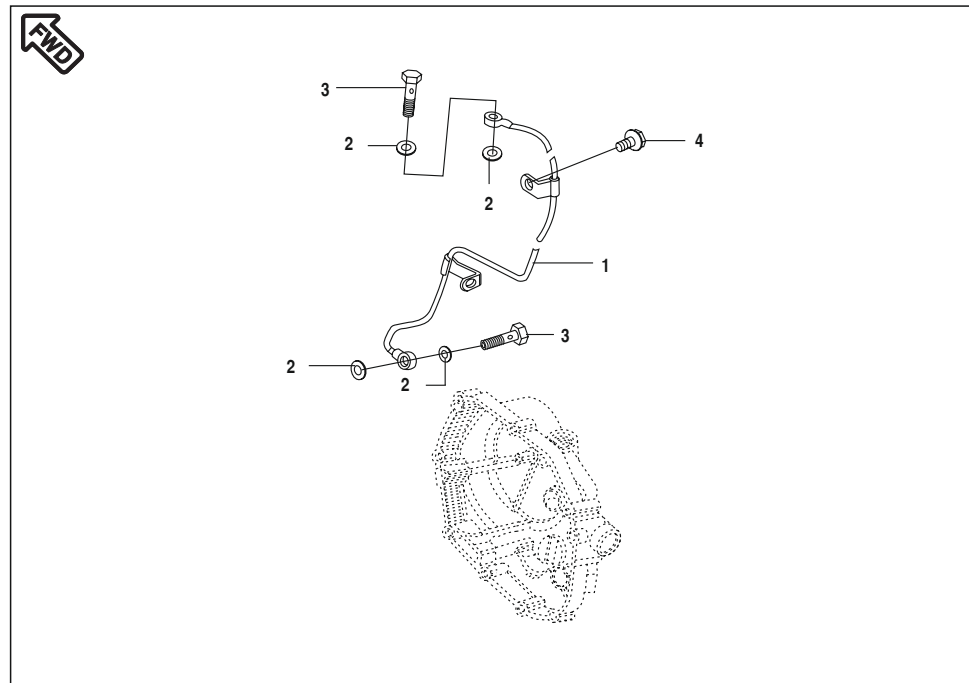

No.	Part No.	Description	Qty/ Veh.	Remarks
1	DU 1210 05	Pipe Oil	1	Use with Bkt. Engine Front RH DU161094
2	DD 1015 17	Gasket	4	
3	39 1023 04	Bolt	2	
4	39 1062 04	Bolt flanged small	2	

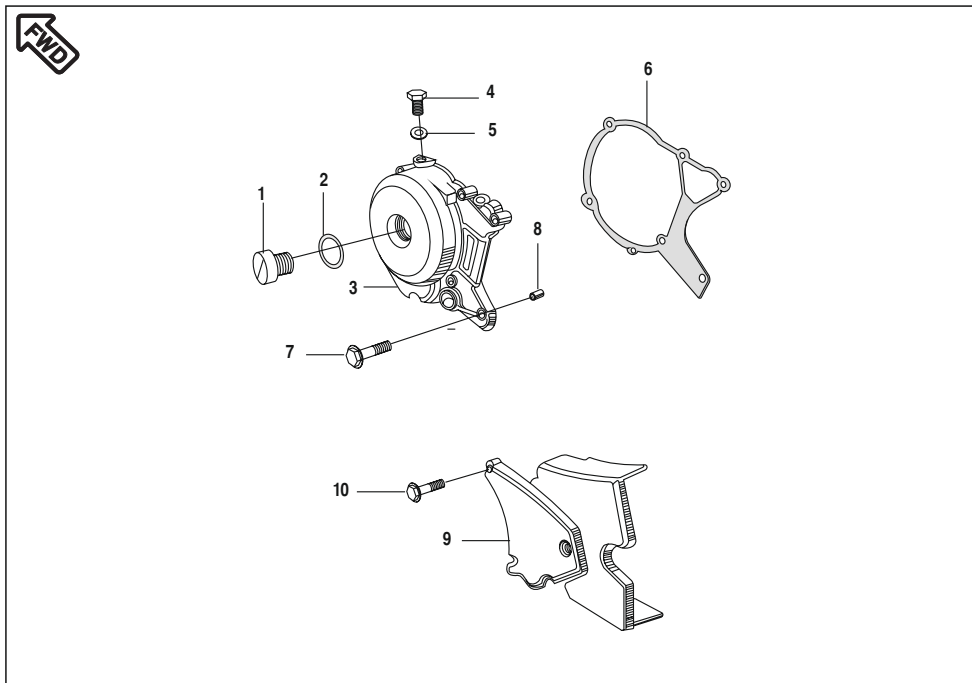

No.	Part No.	Description	Qty/ Veh.	Remarks
1	31 1010 62	Bolt	1	
2	39 1019 21	Ring "O"	1	
3	31 1012 95	Cover Generator	1	
4	31 1010 61	Plug	1	
5	31 1011 13	Gasket	1	
6	DM 1011 39	Gasket - Generator Cover	1	
7	39 1074 04	Bolt Flanged Small	5	
8	39 0999 06	Pin	2	
9	52 DM00 86	Cover Chain (Engine)	1	
10	39 2147 04	Bolt Flanged Small	3	

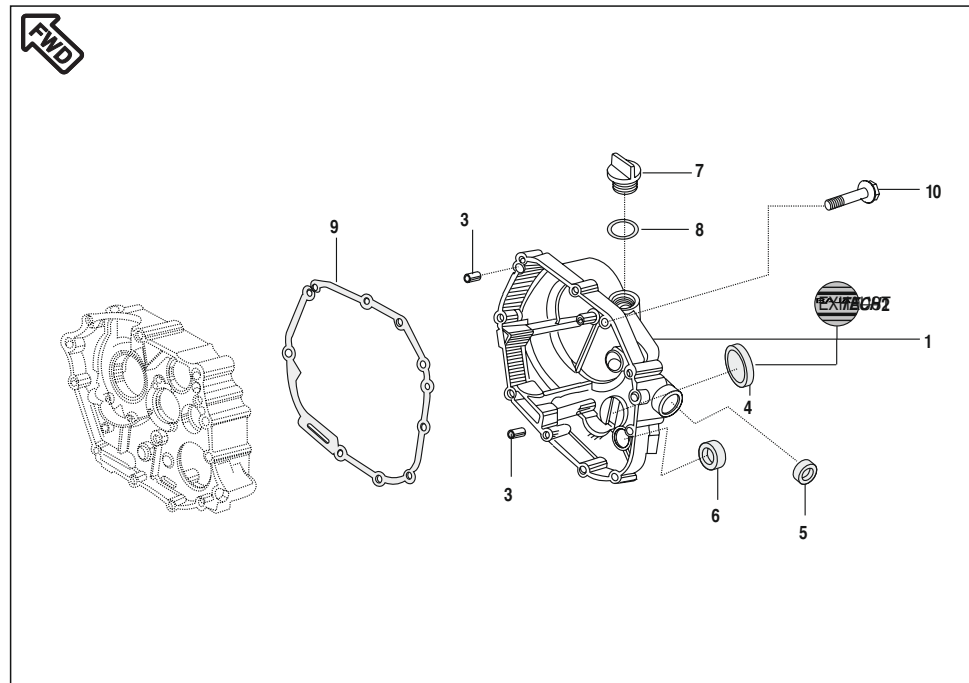

No.	Part No.	Description	Qty/ Veh.	Remarks
1	DZ 1010 47	Clutch cover / Graphics / Gauge	1	
2	DZ 1010 46	Label "BAJAJ EXHAUSTEC"	1	N.S
3	39 0999 06	Dowel Pin	2	
4	31 1010 67	Guage	1	
5	39 1041 19	Seal oil	1	
6	30 1011 42	Seal oil	1	
7	DD 1013 25	Cap oil filler	1	
8	39 2134 21	O ring	1	
9	DM 1011 40	Gasket (Clutch cover)	1	
10	39 1075 04	Bolt flanged small	10	

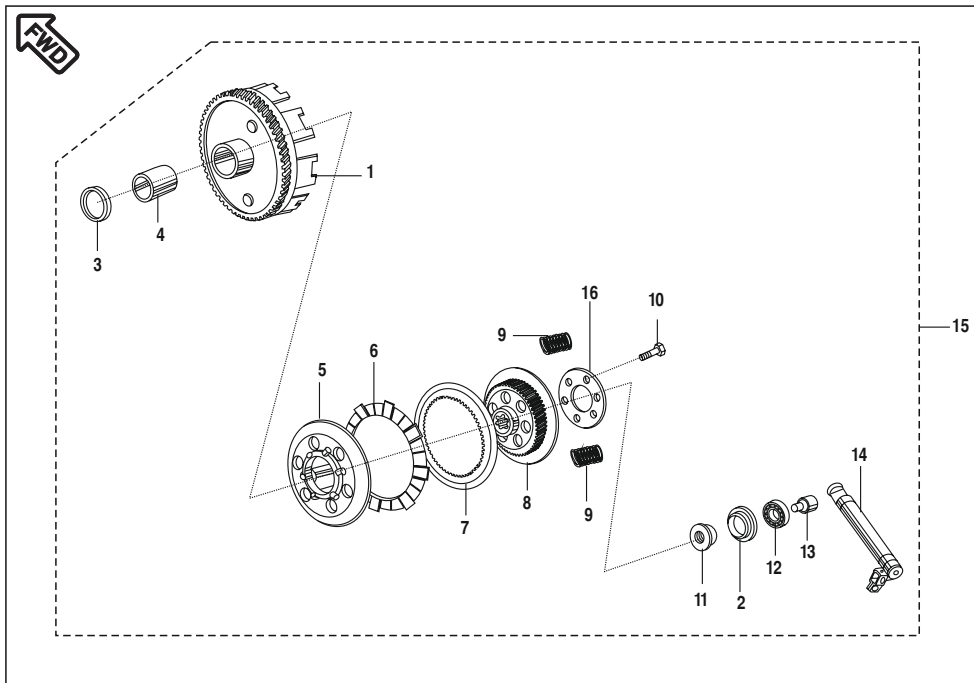

No.	Part No.	Description	Qty/ Veh.	Remarks
1	DX 1010 54	Housing Comp. clutch	1	
2	28 1011 95	Holder	1	
3	39 2600 11	Plain Washer	2	
4	DU 1011 09	Collar	1	
5	DD 1014 92	Wheel Clutch	1	
6	36 DD40 08	Kit Plate Friction	1	
7	30 1010 96	Plate Clutch	4	
8	DD 1014 93	Hub Clutch	1	
9	28 1012 14	Spring	6	
10	39 0980 04	Hex. Bolt	6	
11	39 1053 15	Hex. Nut / Flange	1	
12	39 2403 20	Bearing	1	
13	31 1011 48	Rod Push	1	
14	DX 1010 35	Lever Assly. Complete	1	
15	DX 1010 55	Clutch Assly. Complete	1	
16	31 1011 37	Holder	1	

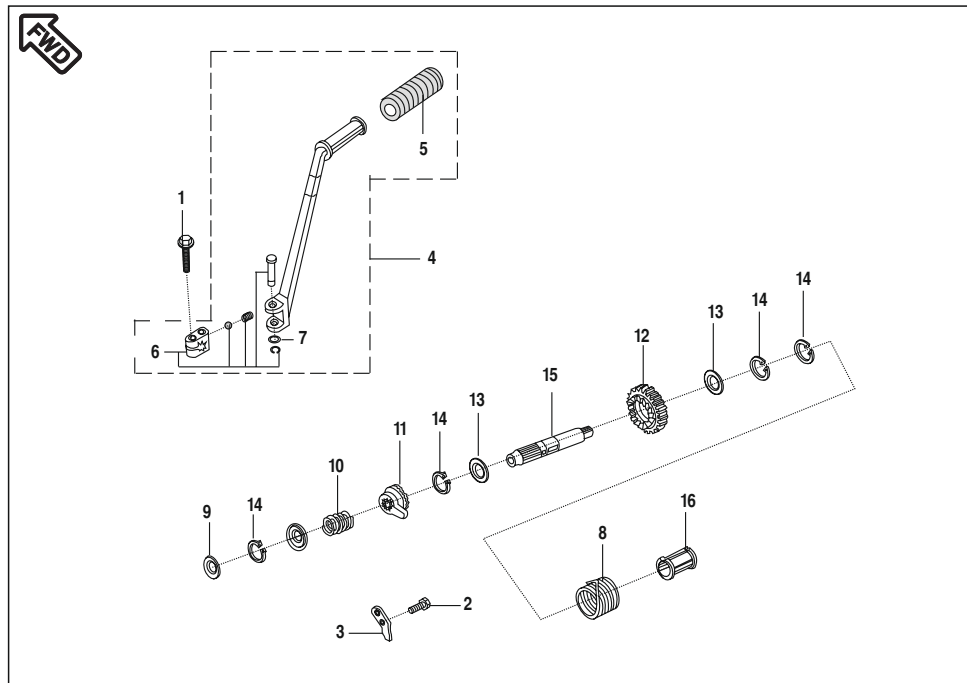

No.	Part No.	Description	Qty/ Veh.	Remarks
1	59 0400 25	Flanged bolt	1	N.S
	JA 6212 06	Flanged bolt	1	Alt. For. 59 0400 25
2	DD 1012 64	Screw Pan Cross	2	N.S
3	DD 1012 54	Guide Kick	1	
4	DU 1010 50	Lever Assly Kick Comp.	1	
5	30 1011 54	Bush(Damper)	1	
6	36 DU10 07	Boss Kick Set	1	Ref. Page No. 50
7	22 1502 41	Plain Washer	1	
8	31 1010 41	Spring	1	
9	39 0993 11	Plain Washer	1	
10	31 1010 39	Coil Spring	1	
11	31 1010 38	Ratchet	1	
12	DU 1010 38	Gear Spur Kick Start	1	
13	39 0995 11	Plain Washer	2	
14	39 0738 17	External Circlip Type C	4	
15	DU 1010 45	Shaft Kick	1	
16	31 1010 40	Guide	1	

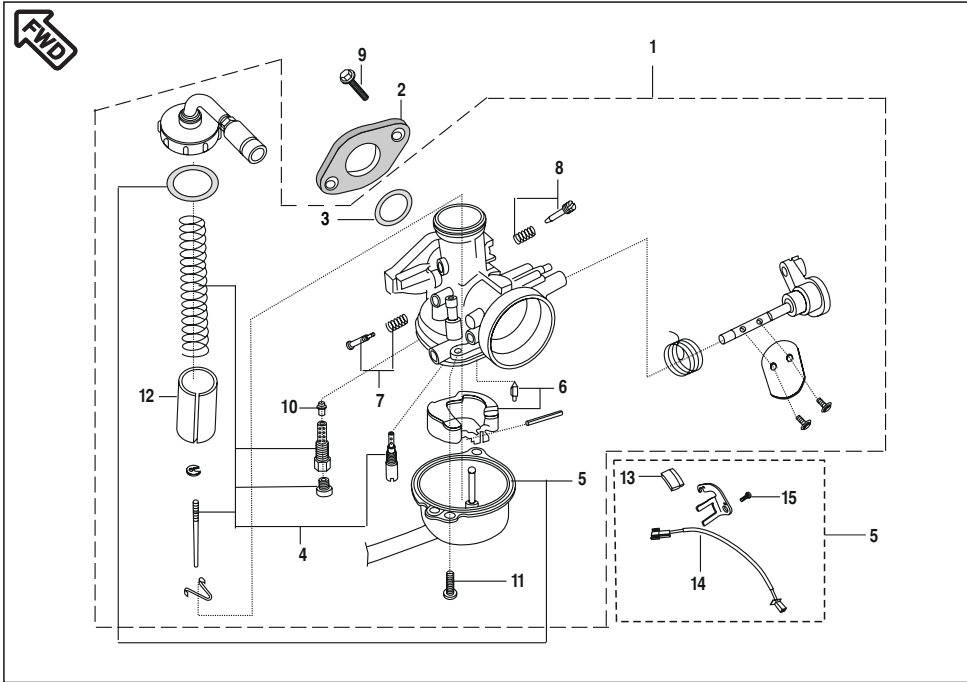

No.	Part No.	Description	Qty/ Veh.	Remarks
1	DU 1210 09	Carburettor Assly. (PB-16)	1	
2	DU 1010 57	Insulator (Carburettor / Intake)	1	
3	39 1283 21	O ring	1	
4	36 DU12 06	Carburettor Holder / Jet Kit	1	Ref. Page No. 51
5	36 DU12 04	Gasket O ring Kit for Carb.	1	Ref. Page No. 51
6	36 DU12 05	Carburettor Float pin Kit	1	Ref. Page No. 51
7	36 DU12 02	Idling Screw kit	1	Ref. Page No. 51
8	36 DU12 03	Air Control Screw Kit	1	Ref. Page No. 51
9	DU 1012 28	Flanged bolt	2	For mounting Carburettor
10	DU 1210 28	Seat for Jet Needle	1	
11	DD 1211 71	Screw with washer	2	
12	DU 1210 17	Valve throttle	1	
13	DH 1211 01	Magnet Assly.	1	
14	DH 1211 02	Reed Switch Assly.	1	Parts
15	39 1062 04	Bolt Flanged Small	1	TPS Mounting
16	DD 1110 46	TPS Assly.	1	

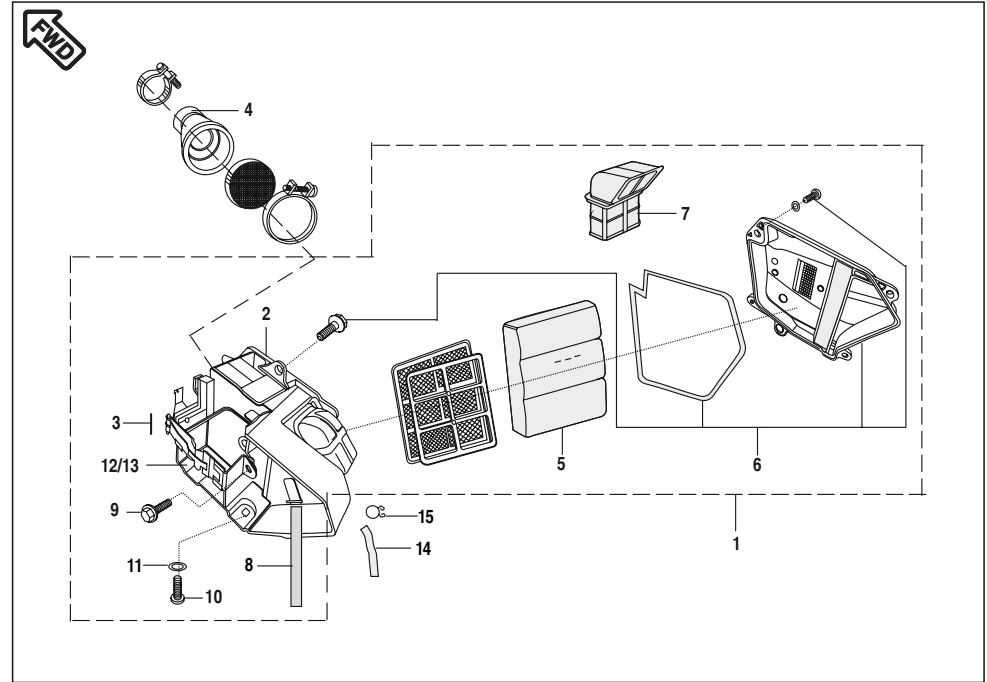

No.	Part No.	Description	Qty/ Veh.	Remarks
1	DF 1210 23	Filter assly air	1	
2	DF 1210 25	Case air filter	1	
3	39 0986 08	Pin Cotter	1	
4	DU 1210 08	Duct (A/F to Carburettor)	1	
5	31 1210 29	Element air filter	1	
6	36 DU12 01	Air filter Kit	1	Ref. Page No. 50 N.S
7	DH 1211 03	Duct (Inlet)	1	N.S
8	DM 2210 01	Band - Tool kit	1	
9	39 1680 04	Flanged bolt (Battery)	1	
10	39 2407 01	Screw (Mounting air filter)	2	N.S
11	39 1789 24	Washer (Nylon)	2	
12	DM 1210 10	Band (Battery)	1	
13	31 1610 07	Damper battery	2	N.S
14	DM 1210 14	Tube oil drain	1	
15	DG 1210 02	Clamp	1	

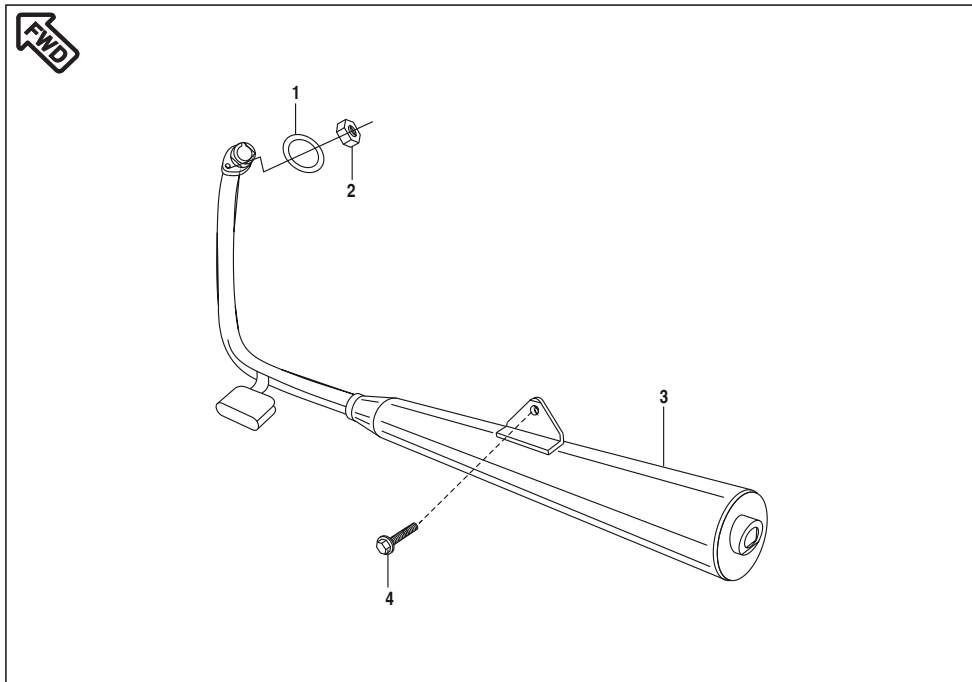

No.	Part No.	Description	Qty/ Veh.	Remarks
1	31 10 1014	Gasket	1	Exhaust-Tec
2	DU 1012 06	Nut	2	
3	DU 1011 96	Assembly Silencer Comp.	1	
4	DD 1013 66	Flanged Bolt	1	

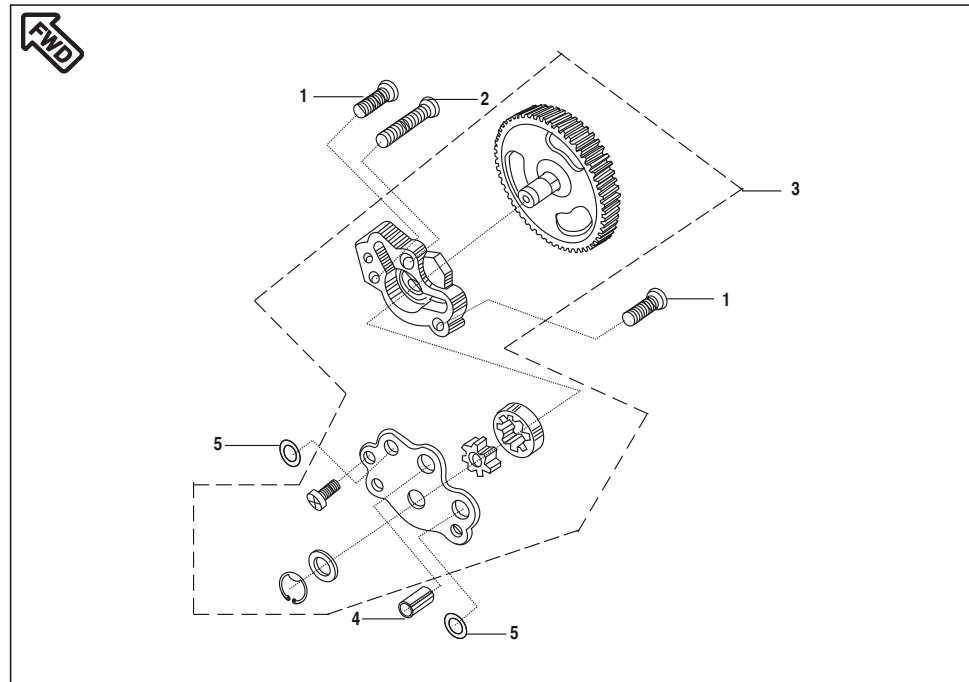

No.	Part No.	Description	Qty/ Veh.	Remarks
1	39 1078 01	Screw Pan Cros	2	
2	39 0753 01	Screw Pan Cros	1	
3	DF 1210 03	Pump Assly. Oil	1	
4	39 0999 06	Pin dowel	1	
5	39 1013 21	Ring O	2	

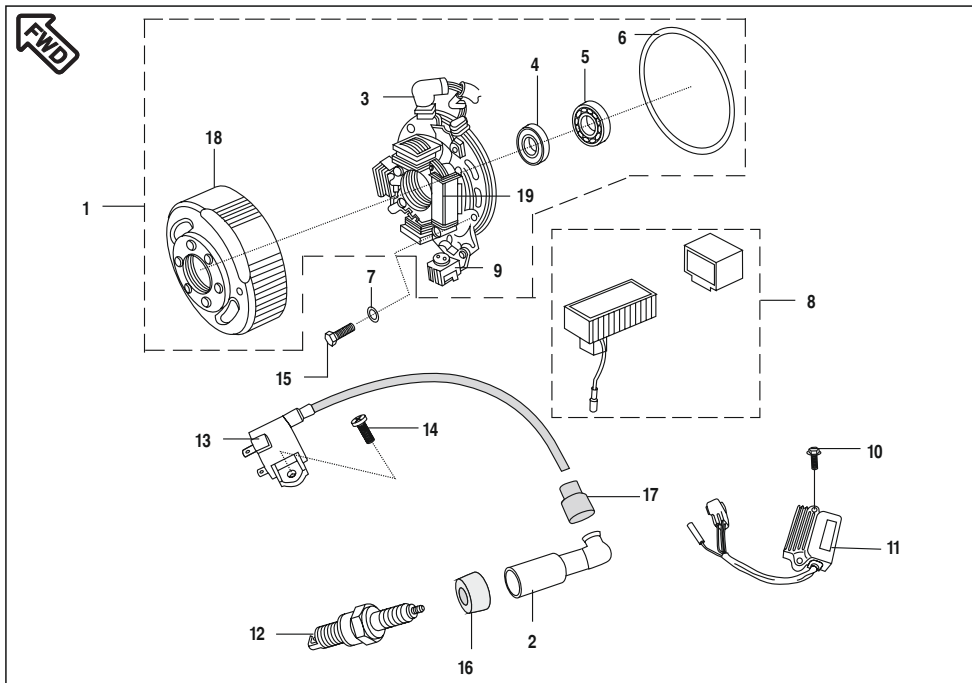

No.	Part No.	Description	Qty/ Veh.	Remarks
1	DF 1110 15	Magneto assly/Brg. & Oil Seal	1	
2	DD 1110 48	Cap Spark plug ®	1	
3	DF 1110 20	Stator assly	1	
4	39 1042 19	Seal Oil (HTA make)	1	
5	39 1003 20	Bearing ball	1	
6	39 1028 21	Ring O	1	
7	39 1659 11	Plain washer	3	
8	DZ 1110 02	Ignitor assly (C.D.I.) / Damper	1	
9	31 1110 58	Pulser Coil	1	
10	39 1553 04	Flanged Bolt	2	
11	DU 2010 62	Regulator/Rectifier (R/R) unit	1	
12	DD 1110 18	Plug Spark (P-RZ9HC)	1	
13	DF 1110 40	H. T. Coil	1	
14	39 0745 01	Screw pan cross	1	
15	DD 1013 18	Bolt	3	N.S
16	DD 1110 11	Grommet Spark plug Cap	1	
17	DD 1110 12	Grommet H.T.Cable	1	
18	DF 1110 16	Magneto Assly	1	
19	31 1110 56	Coil Assembly - Excitor	1	

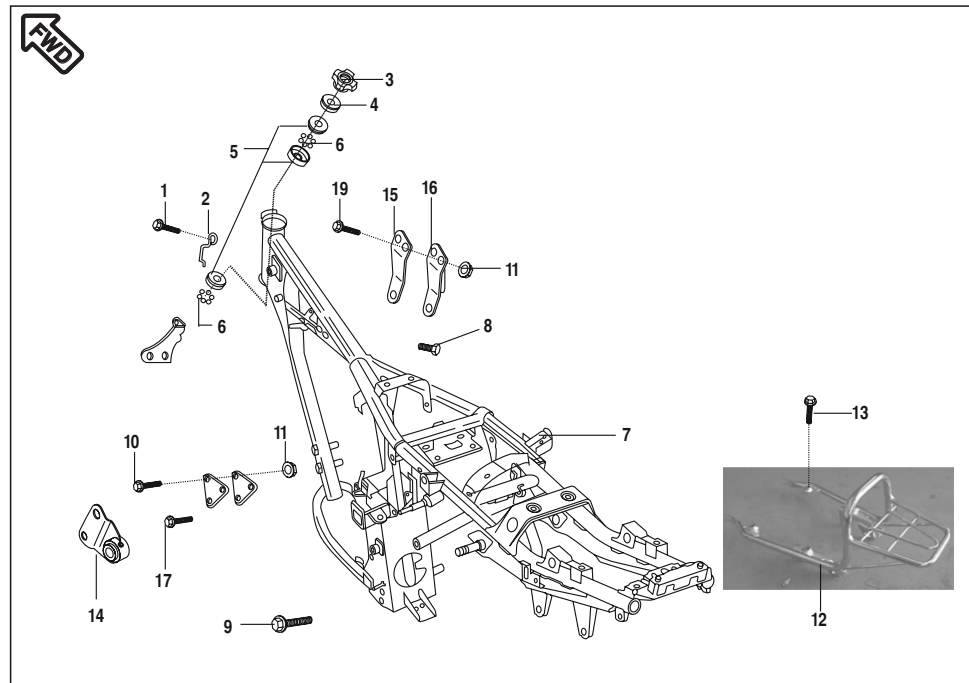

No.	Part No.	Description	Qty/ Veh.	Remarks
1	39 2473 04	Flanged Bolt	1	
2	31 1910 02	Clamp	1	
3	DF 1810 90	Nut	1	
4	DF 1810 52	Cap Steering	1	
5	36 3140 01	Bearing cone kit	1	Ref. Page No. 50
	36 3140 05	Bearing cone kit	1	Alt. For. 36 3140 01
6	36 3140 02	Kit Ball Steel	1	
7	DM 1611 20	Frame Comp./Brg.races	1	
8	39 2222 04	Flange Bolt	4	
9	39 2702 04	Hex. Bolt	1	Engine Mounting Rubber N.S
10	39 2469 04	Flanged Bolt	1	
11	59 1500 05	Flange Nut	5	
12	DM 2210 08	Grip frame	1	Black Powder Coated
13	39 1556 04	Flanged bolt	2	
14	DU 1610 93	Bracket Engine Front/Bush LH	1	
	DU 1610 94	Bracket Engine Front/Bush RH	1	
15	DD 1610 53	Bracket Engine Upper LH	1	
16	DF 1611 68	Bracket Engine Upper RH	1	
17	39 2700 04	Flange Bolt	1	
18	DF 1810 24	Lock Set (4 in 1)	1	
19	39 2455 04	Bolt	2	N.S

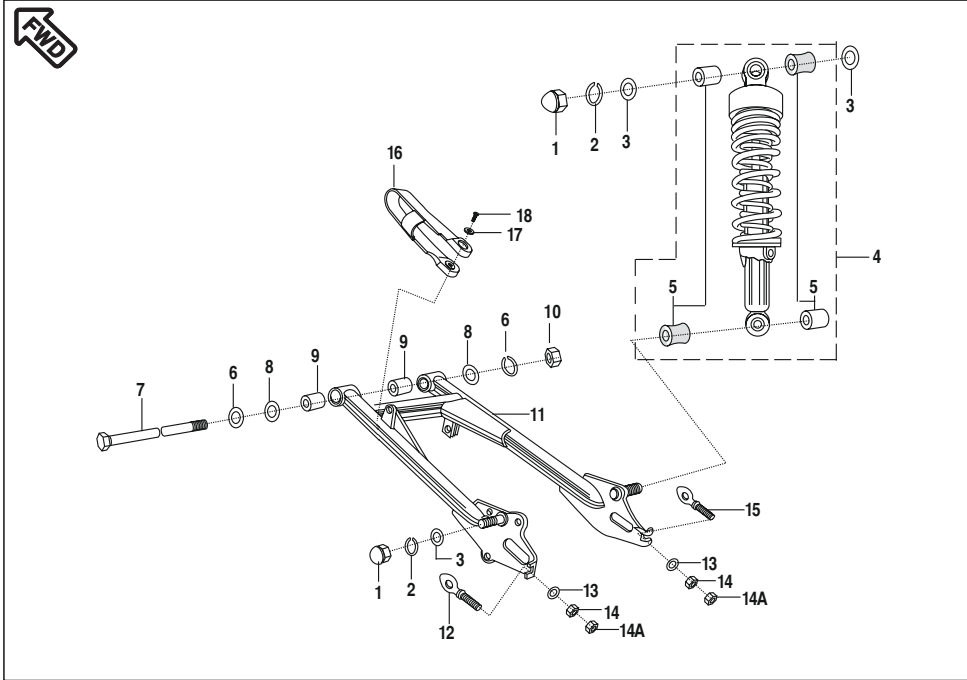

No.	Part No.	Description	Qty/ Veh.	Remarks
1	39 0712 15	Domed Cap Nut	4	
2	39 0737 12	Washer Spring	4	
3	39 0714 11	Washer Plain	8	
4	DM 1710 27 DM 1710 25	Rear Shock Absorber	2	Endurance Make Gabriel Make
5	36 DF17 01	Rubber Inner Bush kit	1	Ref. Page No. 50
6	39 0248 11	Plain Washer	2	
7	31 1710 06	Shaft Swing Arm	1	
8	39 0201 11	Plain Washer	2	
9	30 1710 18	Bushing Rubber	2	
10	39 1225 15	Nut Hex./ flange	1	
11	DM 1710 18 DM 1713 19	Arm Comp. Swing / Bush Arm Comp. Swing	1	Ref. Circular IB-88
12	52 DZ00 46	Adjuster Chain S/A (RH)	1	
13	39 0711 11	Washer Plain	2	
14	39 2764 15	Hex Nut	2	N.S
14A	39 0292 15	Nut	2	
15	52 DZ00 47	Adjuster Chain S/A (LH)	1	
16	31 1710 12	Damper for Swing arm	1	
17	39 0454 11	Plain washer	2	
18	39 0553 02	Self tapping Screw	2	

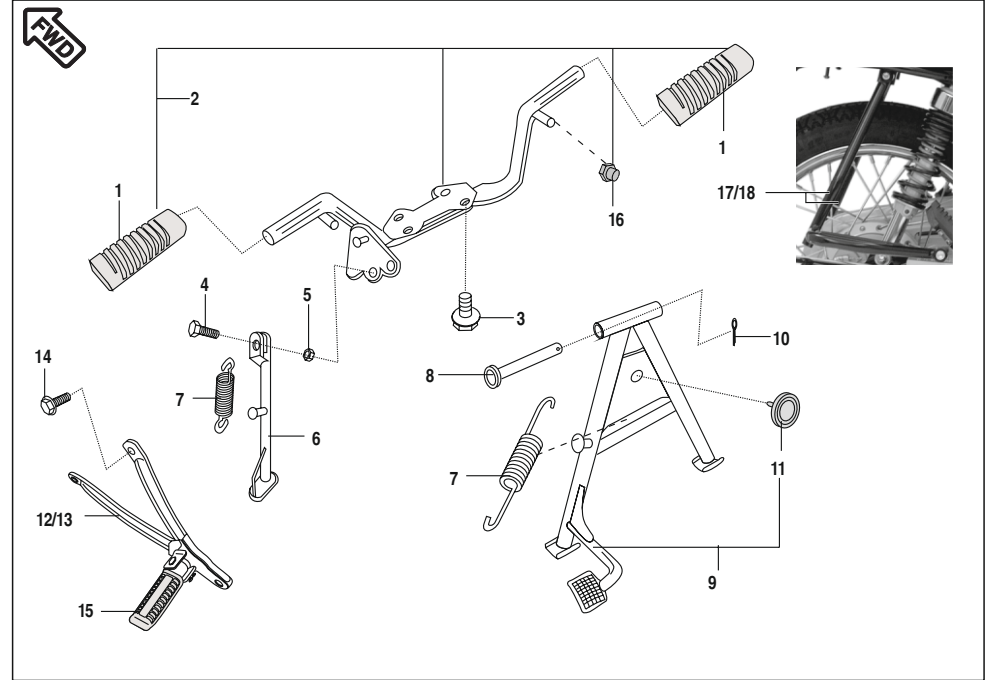

No.	Part No.	Description	Qty/ Veh.	Remarks
1	DF 1614 13	Damper (PVC)	2	
2	DF 1614 25	Holder Step/Damper/Kick Stopper	1	
3	39 2481 04	Flanged Bolt	4	
4	DF 1611 02	Bolt for Side Stand Mounting	1	
5	39 0422 15	Nyloc Nut	1	
6	DL 1610 48	Stand Side	1	
7	30 1611 58	Spring	2	
8	30 1611 57	Shaft Stand	1	
9	DU 1610 32	Stand Centre / Damper	1	
10	39 0787 08	Pin Cotter	1	
11	DG 1611 24	Damper	1	
12	DU 1611 44	Stay LH	1	
13	DU 1611 45	Stay RH	1	
14	39 2481 04	Hex bolt flanged	2	
15	DX 1610 56	Rubber Pillion Step (PVC)	2	
16	DH 1611 94	Kick Stopper	1	
17	DM 1611 46	Third Footrest LH	1	
18	DM 1611 47	Third Footrest RH	1	



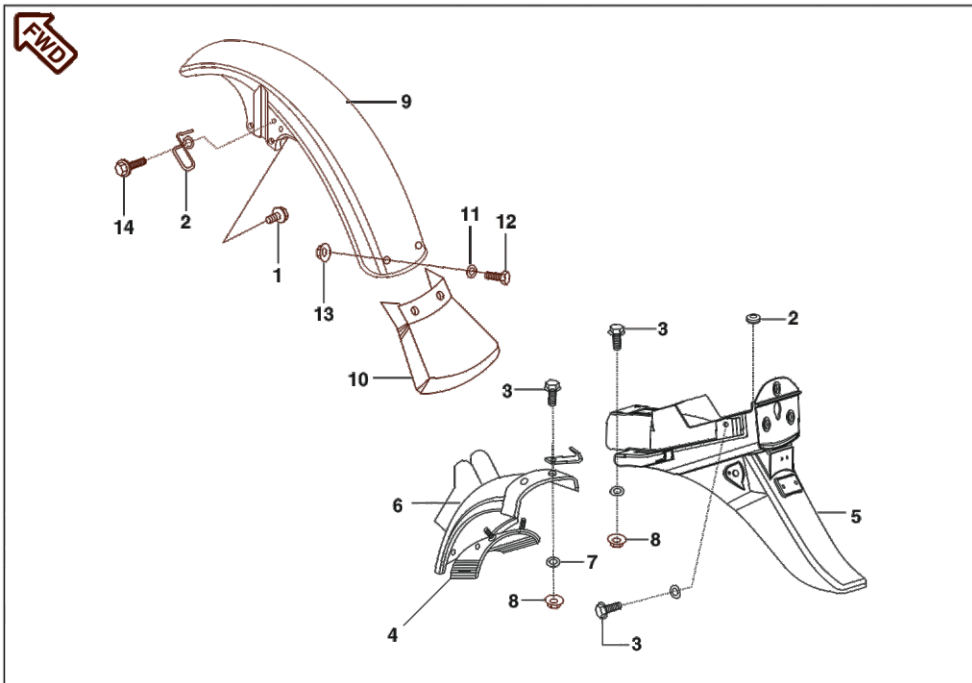

No.	Part No.	Description	Qty/ Veh.	Remarks
1	39 2222 04	Flanged Bolt	4	
2	DF 1910 20	Clamp	1	
3	39 2483 04	Flanged Bolt	4	
4	DD 1610 51	Flap	1	
5	DF 1611 04	Fender Rear	1	
6	DM 1610 09	Fender Rear Front	1	
7	39 0711 11	Plain Washer	4	
8	39 0817 15	Hex. Nut Flanged	4	
9	DF 1612 42	Front Fender	1	
10	DF 1612 45	Mud Flap - Front	1	
11	01 1106 09	Plain Washer	2	
12	22 1504 35	Bolt	2	
13	39 2484 15	Flange Nut	2	
14	39 2473 04	Flange Bolt	1	

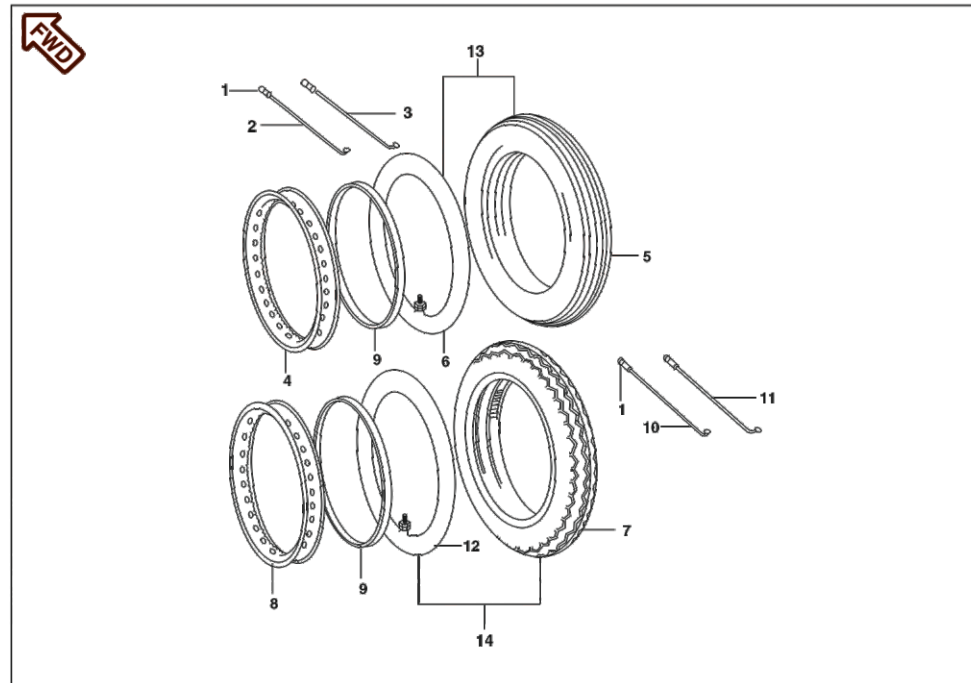

No.	Part No.	Description	Qty/ Veh.	Remarks
1	16 1510 66	Nipple Spoke	72	
2	DU 1510 25	Spoke Inner Front	18	
3	DU 1510 26	Spoke Outer Front	18	
4	DM 1510 29	Wheel Rim Front (1.6 x 17)	1	
5	DS 1510 48	Tyre Front 2.75 X 17	1	N.S
6	DS 1510 49	Tube Front 2.75 X 17	1	
7	DM 1510 28	Tyre Rear 3 X 17	1	
8	DS 1510 46	Wheel Rim Rear (1.85 x 17)	1	
9	DG 1510 22	Band Rim	2	
10	DS 1510 09	Spoke Inner Rear	18	
11	DS 1510 10	Spoke Outer Rear	18	
12	DS 1510 53	Tube Rear	1	
13	DS 1510 47	Tyre and Tube Front 2.75 x 17	1	
14	DM 1510 27	Tyre and Tube Rear	1	

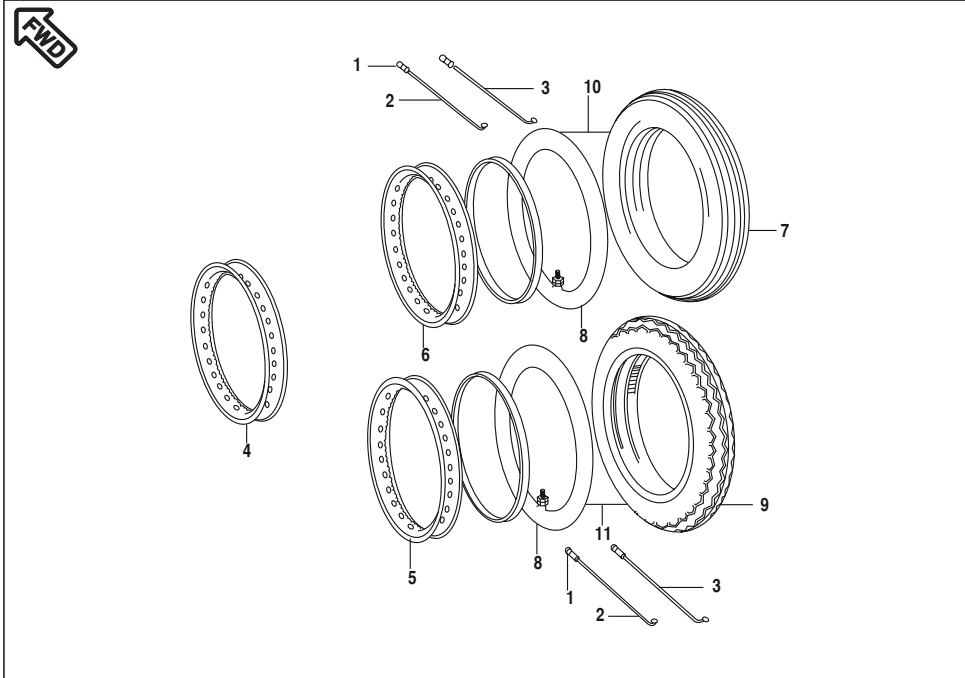

No.	Part No.	Description	Qty/ Veh.	Remarks
1	16 1510 66	Nipple Spoke	72	
2	DF 1510 05	Spoke Inner	36	
3	DU 1510 25	Spoke Inner	36	For 17" Wheel
3	DF 1510 06	Spoke Outer	36	
3	DU 1510 26	Spoke Outer	36	For 17" Wheel
4	DM 1510 08	Wheel Rim Rear and Front	2	For 18" Wheel
5	DU 1510 18	Wheel Rim Rear	1	For 17" Wheel
6	DM 1510 29	Wheel Rim Front	1	For 17" Wheel
7	DS 1510 48	Tyre Front	1	For 17" Wheel N.S
8	DS 1510 49	Tube	2	N.S
9	DS 1510 52	Tyre Rear	1	For 17" Wheel N.S
10	DM 1510 24	Tyre with Tube Front	1	For 17" Wheel
11	DM 1510 27	Tyre with Tube Rear	1	For 17" Wheel

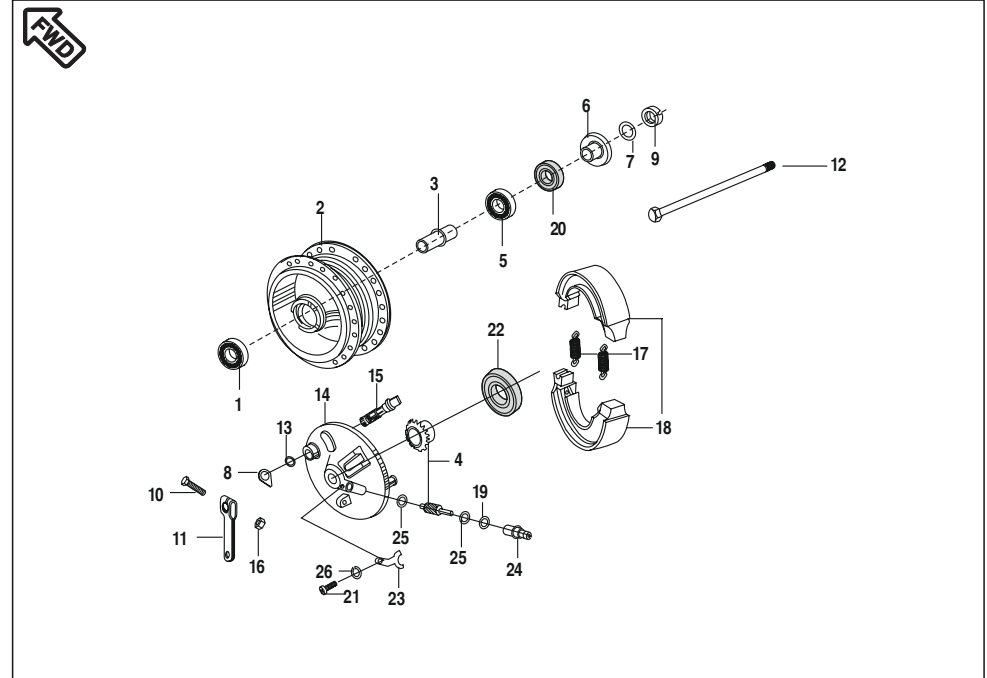

No.	Part No.	Description	Qty/ Veh.	Remarks
1	39 2680 20	Ball Bearing	1	6300RS1/C3
2	DF 1510 03	Drum Front	1	
3	31 1510 04	Collar	1	
4	36 DU15 03	Gear Meter Screw Kit	1	Ref. Page No. 50
5	39 2681 20	Ball Bearing	1	6200RS1/C3
6	DU 1510 05	Collar Axle Assly.	1	
7	39 0248 11	Plain Washer	1	
8	DD 1510 09	Indicator Front	1	
9	DU 1510 31	Nut Hex. Slotted	1	
10	39 0775 04	Bolt	1	
11	DD 1510 08	Lever Brake Cam	1	
12	31 1510 36	Axle	1	Upto 2005 N.S
12	DZ 1510 12	Axle	1	From 2006
13	30 1510 38	Ring O	1	
14	DZ 1510 27	Panel Front Brake	1	
15	31 1510 11	Cam Brake	1	

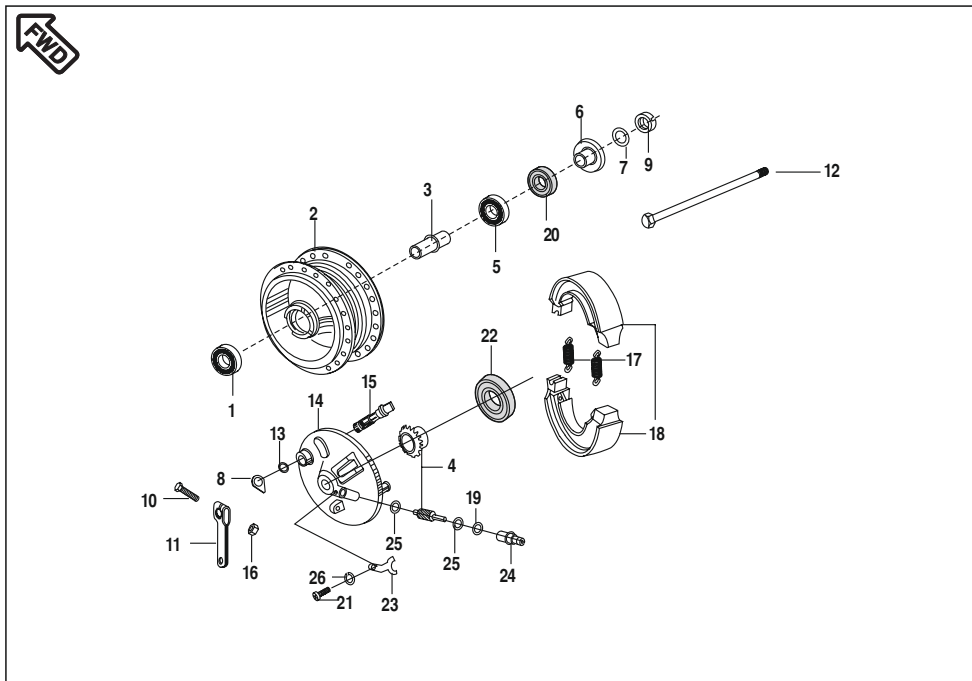

No.	Part No.	Description	Qty/ Veh.	Remarks
16	39 0798 15	Flange Nut	1	
17	30 1510 69	Spring	2	
18	31 1510 60	Shoe Brake Assly.	2	
19	39 1013 21	Ring 'O'	1	
20	14 1510 21	Oil Seal	1	
21	39 0840 01	Screw pan Cross	1	
22	31 1510 14	Oil Seal	1	
23	30 1511 18	Stopper Fro bushing	1	
24	JA 1316 06	Bushing	1	
25	30 1510 42	Washer	2	
	39 0242 11	Washer	2	Alt. For 30 1510 42
26	39 0900 12	Spring Washer	1	

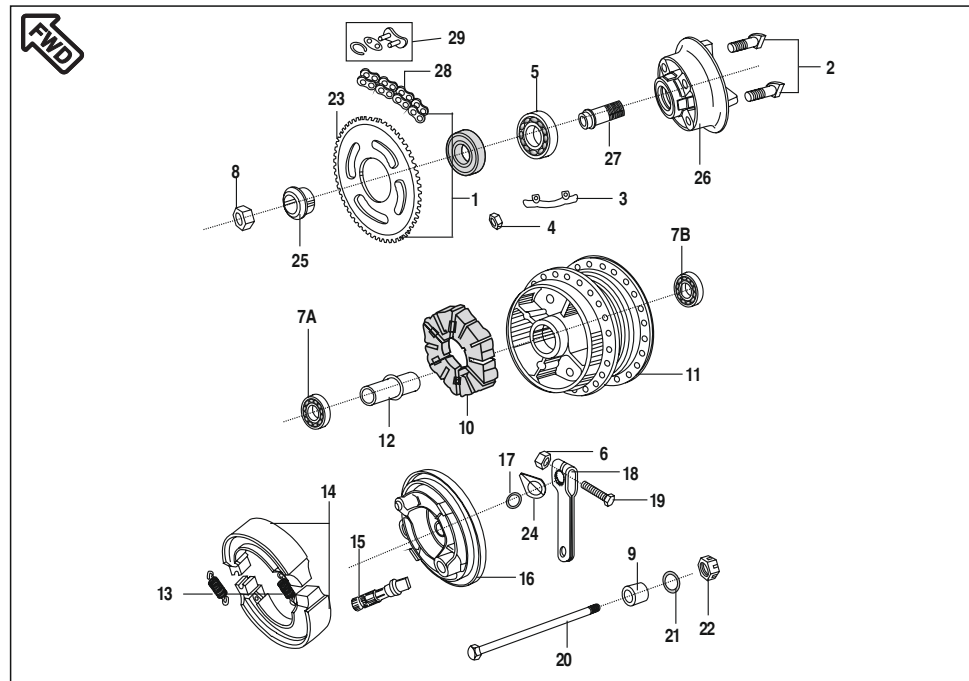

No.	Part No.	Description	Qty/ Veh.	Remarks
1	36 DU15 05	Chain Sprocket Kit 110mm Rr. Dr.	1	Ref. Page No. 53
	36 DM00 01	Chain Sprocket Kit 130mm Rr. Dr.	1	
2	DP 1510 28	'D' bolt	6	
3	30 1510 81	Washer	2	
4	39 0794 15	Nut Hex. Fine	4	
5	39 2240 20	Bearing Ball	1	
6	39 0798 15	Hex. nut	1	
7A	39 2686 20	Bearing Ball 6202 RS1/C3	1	15X35X11
7B	39 2687 20	Bearing Ball 6302 RS1/C3	1	15X42X13
8	39 0988 15	Nut Hex.	1	
9	31 1510 26	Collar	1	
10	DP 1510 27	Shock Damper	4	
11	30 1510 63	Drum Rear	1	Alt. DF 1510 09
12	30 1510 75	Collar Assly.	1	
13	30 1510 69	Spring	2	
14	30 1511 05	Shoe Brake Assly.	1	
15	30 1510 11	Brake Cam assly	1	

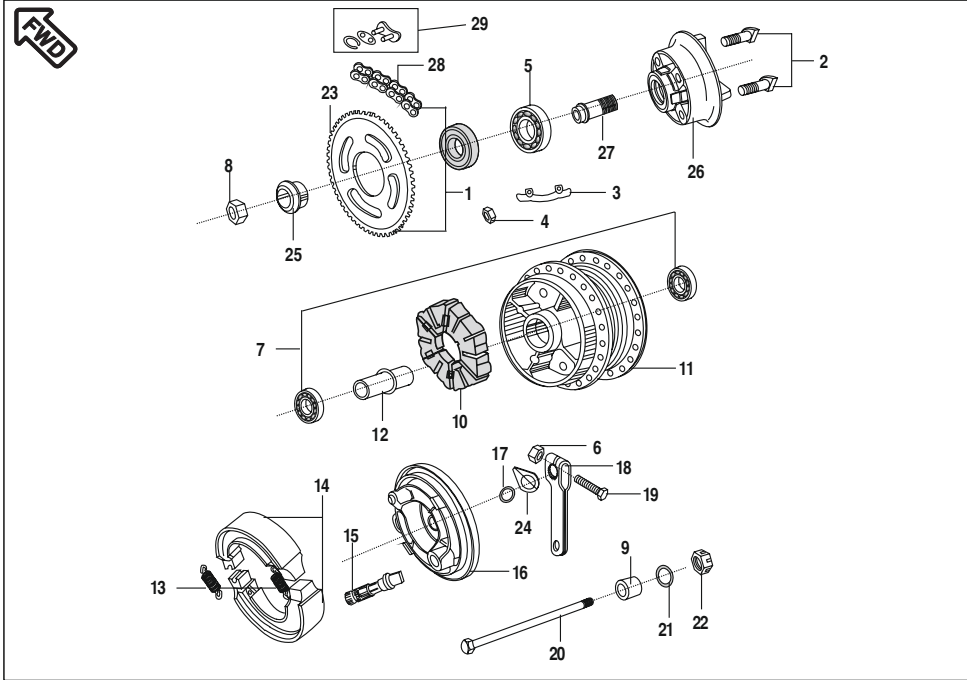

No.	Part No.	Description	Qty/ Veh.	Remarks
16	30 1510 08	Panel Rear Brake	1	
17	30 1510 38	Ring O	1	
18	DD 1510 15	Lever Brake	1	
19	39 2447 04	Bolt	1	
20	DM 1510 32	Axle	1	
21	39 2566 11	Washer Plain	1	
22	DH 1710 19	Nut Castle	1	
23	DJ 1510 18	Sprocket	1	
24	30 1510 05	Indicator	1	
25	DD 1510 09	Indicator	1	Alternate for 30151005
25	31 1510 30	Collar	1	
26	30 1510 78	Coupling	1	
27	30 1510 79	Sleeve	1	
28	DF 1510 23	Chain	1	
29	DX 1510 81	Drive Chain Connecting Link	1	

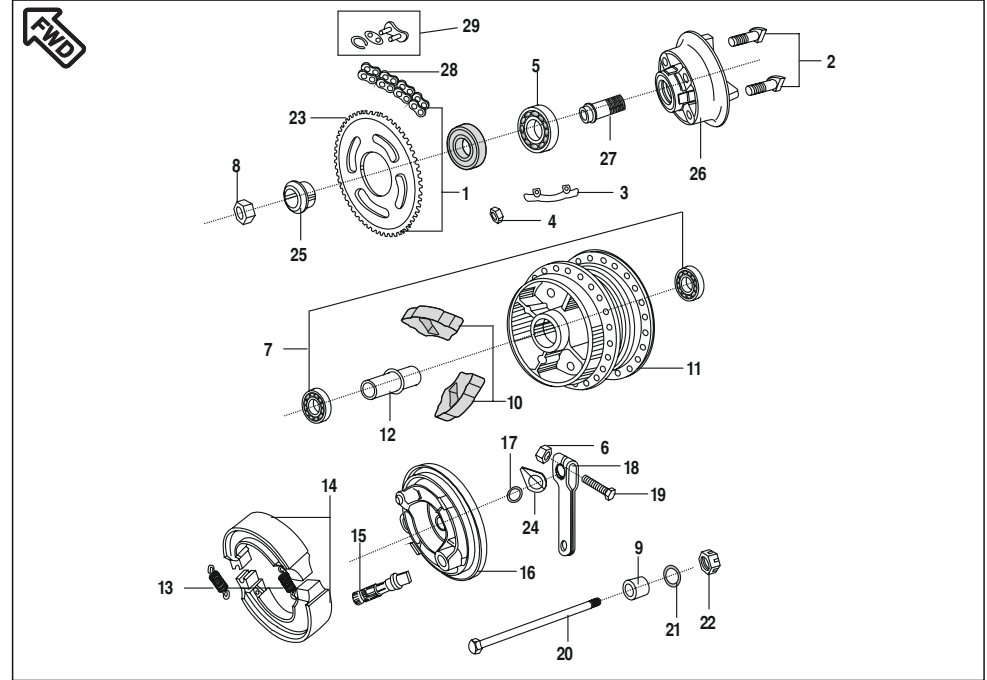

No.	Part No.	Description	Qty/ Veh.	Remarks
1	36 DU15 05	Chain Sprocket Kit	1	Upto Aug.05
	36 DU40 03	Chain Sprocket Kit	1	Between Sep.05 to Dec.05
	36 DU40 17	Chain Sprocket Kit	1	w.e.f. Jan.06
2	39 0978 04	'D' bolt	4	
3	31 15 1029	Washer	2	
4	39 0794 15	Nut Hex. Fine	4	
5	39 2240 20	Bearing Ball	1	
6	39 0798 15	Hex. nut	1	
7	36 DU15 06	Rear Wheel Bearing Kit	1	Ref. Page No.63
8	39 0988 15	Nut Hex.	1	
9	31 1510 26	Collar	1	
10	31 15 1021	Shock Damper	4	
11	DU 1510 09	Drum Rear	1	
12	31 1510 18	Collar Assly.	1	
13	30 15 1069	Spring	2	
14	31 1510 60	Shoe Brake Assly.	1	
15	31 1510 23	Brake Cam Assly.	1	N.S
	JB 1312 23	Brake Cam Assly.	1	Alternate

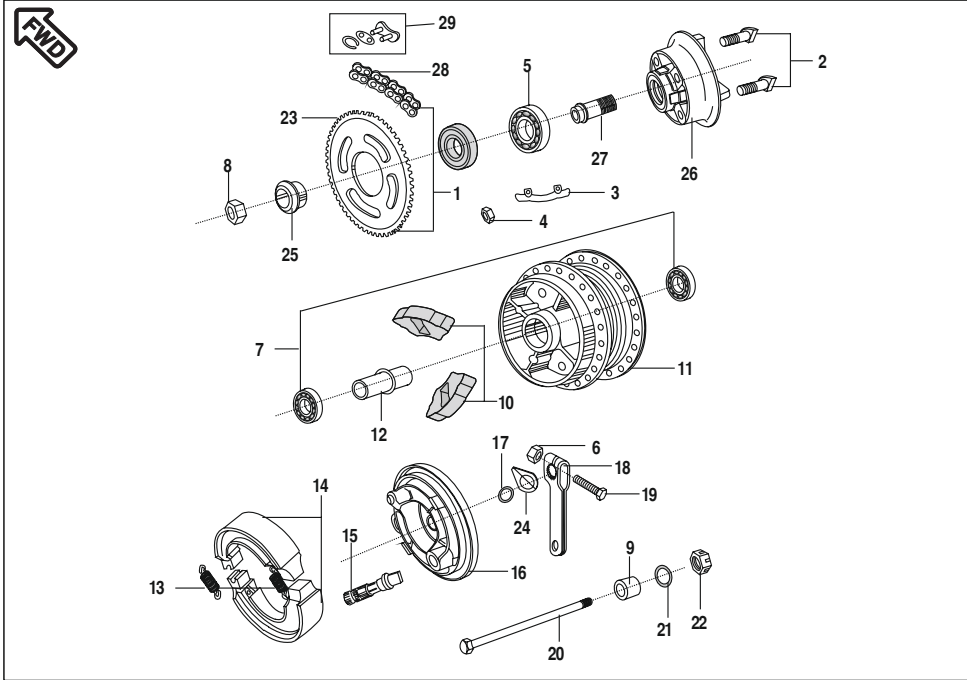

No.	Part No.	Description	Qty/ Veh.	Remarks
16	31 15 1024	Panel Rear Brake	1	
17	30 15 1038	Ring O	1	
18	31 15 1037	Lever Brake	1	
19	39 0775 04	Bolt	1	
20	31 1510 01	Axle	1	
	DU 1520 29	Axle	1	Alternate
21	39 0714 11	Washer Plain	1	
22	DH 1710 19	Nut Castle	1	
23	DM 1510 09	Sprocket 47 T	1	Upto Dec. 05
	DU 1510 27	Sprocket 42 T	1	w.e.f. Jan. 06
24	30 1510 05	Indicator	1	
	DD 1510 09	Indicator	1	Alternate for 30151005
25	31 1510 30	Collar	1	
26	31 1510 27	Coupling	1	
27	31 1510 28	Sleeve	1	
28	DM 1510 05	Chain 114 Link	1	Upto Dec. 05
	DF 1510 23	Chain 112 Link	1	w.e.f. Jan. 06
29	DX 1510 81	Drive Chain Connecting Link	1	

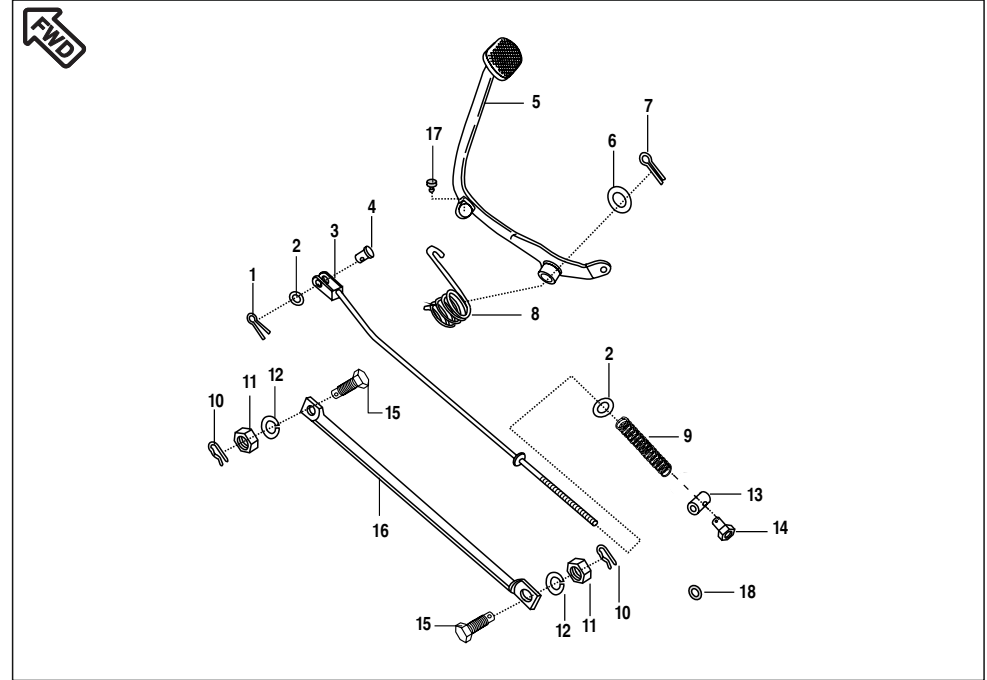

No.	Part No.	Description	Qty/ Veh.	Remarks
1	39 0808 08	Split pin	1	
2	39 0198 11	Plain Washer	2	
3	DM 1910 10	Rod Brake (for 130mm Drum)	1	
	DU 1910 30	Rod Brake (for 110mm Drum)		
4	30 1910 38	Pin	1	
5	DM 1910 16	Lever Brake Tubular	1	N.S
	DZ 1910 04	Lever Brake Tubular	1	Alt. For. DM 1910 16
6	39 0805 11	Washer Plain	1	
7	39 0797 08	Pin Cotter	1	
8	30 1910 31	Spring	1	
9	30 1910 35	Spring	1	
10	39 0807 08	Pin Snap	2	
11	39 0708 15	Nut Hex.	2	
	39 0694 15	Nut Hex.	2	Ref. Circular IB-88
12	39 0789 12	Washer Spring	2	
13	30 1910 38	Pin	1	
14	30 1910 36	Brake adjusting nut	1	
15	30 1510 95	Bolt	2	
	DH 1510 29	Bolt	2	Ref. Circular IB-88
16	DD 1510 14	Torque rod	1	
	DM 1513 17	Torque rod	1	Ref. Circular IB-88
17	DD 1610 78	Damper	1	
18	39 15 40 11	Plain Washer	1	Ref. Circular IB-88

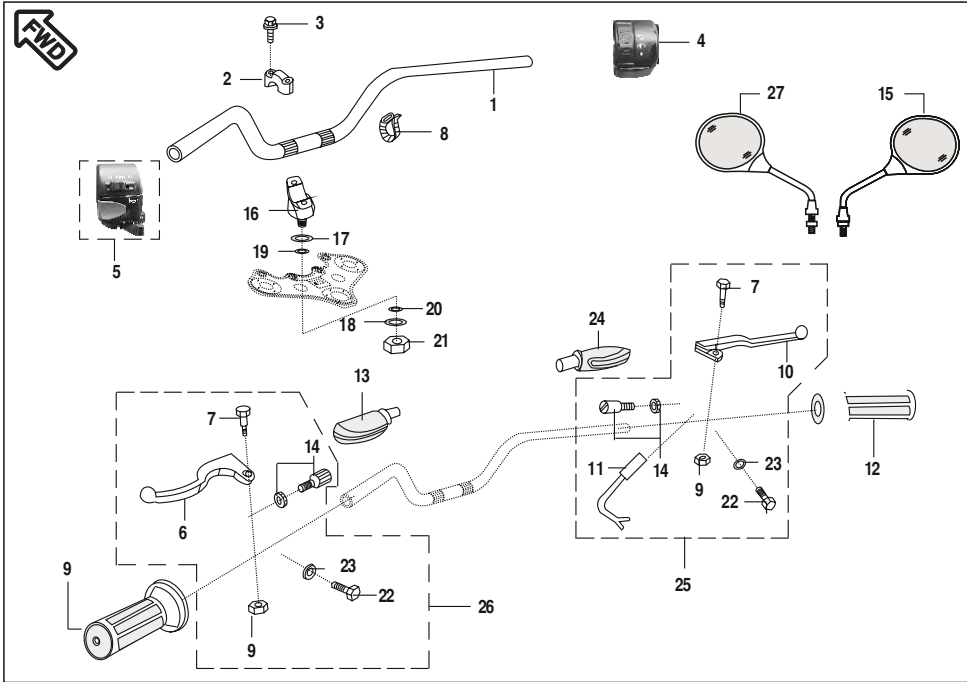

No.	Part No.	Description	Qty/ Veh.	Remarks
1	DF 1811 17	Handle	1	
2	FD 1810 30	Holder Handle Upper	2	
3	39 1074 04	Flanged Bolt	4	
4	DF 2010 53	Control Switch RH	1	
5	DU 1910 33	Control Switch LH	1	
6	DU 1910 35	Lever grip - Left	1	
7	39 0830 01	Stud Lever handle	2	
8	30 1910 48	Band	2	
9	DF 1910 26	Grip - Left hand	1	
10	DF 1910 66	Lever grip - Right	1	
11	DD 2011 70	Front brake switch	1	
12	DF 1910 27	Grip - Right hand	1	
13	DM 1910 14	Boot For Lever LH	1	
14	36 DU19 01	Cable Adjuster kit	1	Ref. Page No. 51
15	DF 2210 07	Mirror RH	1	

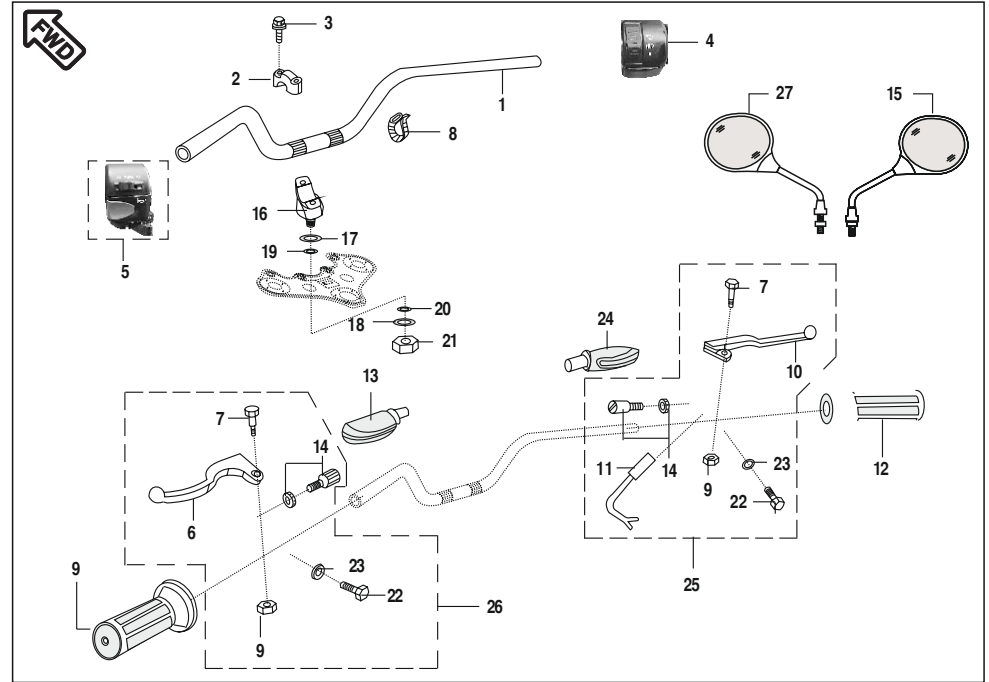

No.	Part No.	Description	Qty/ Veh.	Remarks
16	FD 1810 31	Holder Handle Lower	2	
17	DF 1810 91	Damper Handle Upper	2	
18	DF 1810 92	Damper Handle Lower	2	
19	FD 1810 19	Washer Plain Upper	2	
20	FD 1810 20	Washer Plain Lower	2	N.S
21	39 0422 15	Nylock Nut	2	
22	39 0725 04	Hex.Bolt	2	
23	39 0198 11	Plain Washer	2	
24	DM 1910 15	Boot For Lever RH	1	
25	DU 1910 31	Lever Assly. grip RH	1	
26	DU 1910 33	Lever Assly. grip LH	1	
27	DF 2210 37	Mirror LH	1	

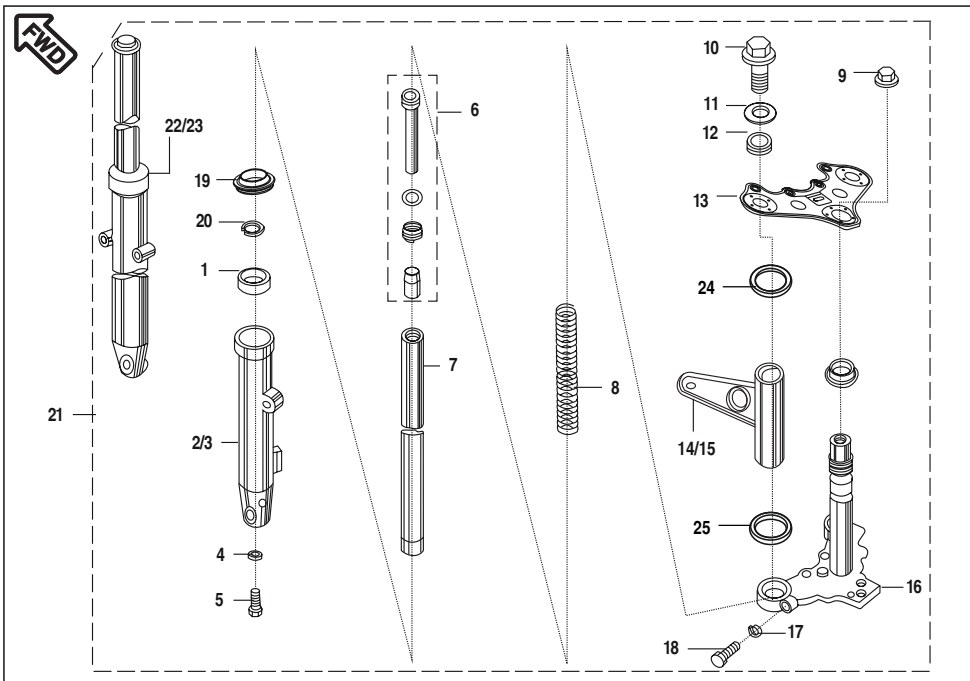

No.	Part No.	Description	Qty/ Veh.	Remarks
1	DL 1810 80	Seal Oil	1	
2	DD 1810 31	Pipe Left Fork Outer	1	
3	DD 1810 34	Pipe Right Fork Outer	1	
4	30 1810 26	Gasket	2	
5	30 1810 25	Bolt	2	
6	31 1810 15	Cyl. Complete Fork	2	
7	DM 1810 36	Pipe Comp. Susp. Inner	2	
8	DE 1810 31	Spring Front Fork	2	
9	FD 1810 12	Cap Special Nut	1	
10	31 1811 20	Bolt Fork	2	
11	30 1810 29	Ring 'O'	2	
12	DF 1810 85	Seat -fork spring:fr fork+shm upper bkt	2	
13	DD 1812 05	Holder Fork Upper	1	
14	DM 1810 39	Cover Fork RH	1	
15	DM 1810 38	Cover Fork LH	1	

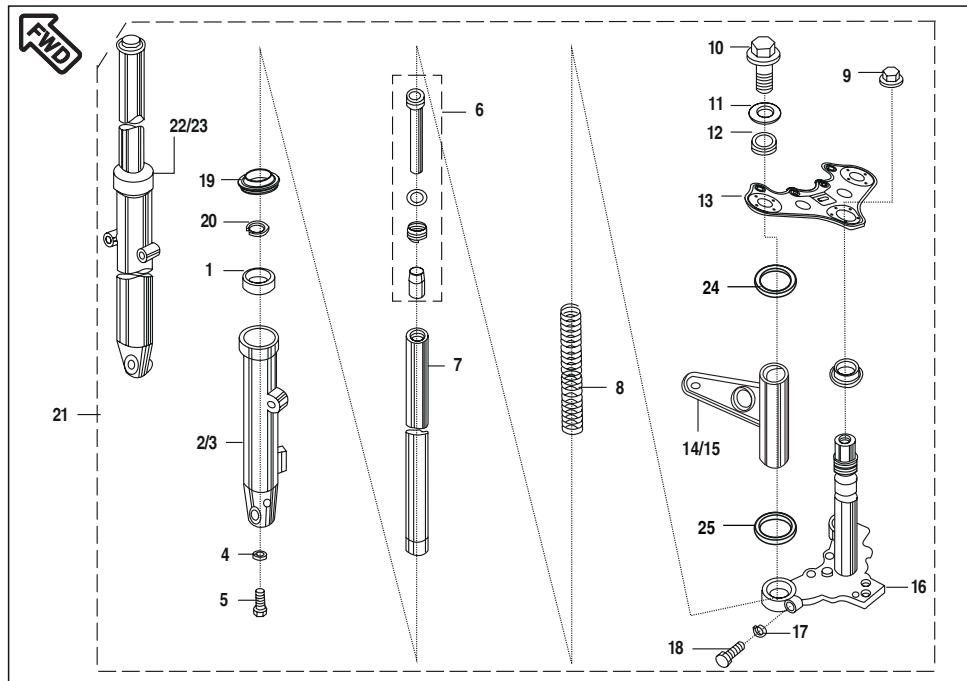

No.	Part No.	Description	Qty/ Veh.	Remarks
16	DF 1810 83	Holder Fork Under	1	
17	39 0789 12	Washer Spring	2	
18	39 1813 04	Bolt Hex.	2	
19	DD 1810 11	Dust seal	2	
20	30 1810 23	Ring snap	2	
21	DM 1810 28	Front Fork	1	
22	DM 1810 29	Damper Assly.LH	1	
23	DM 1810 30	Damper Assly.RH	1	
24	DD 1810 91	Cover Trail Top	2	
25	DD 1810 90	Cover Trail Bottom	2	



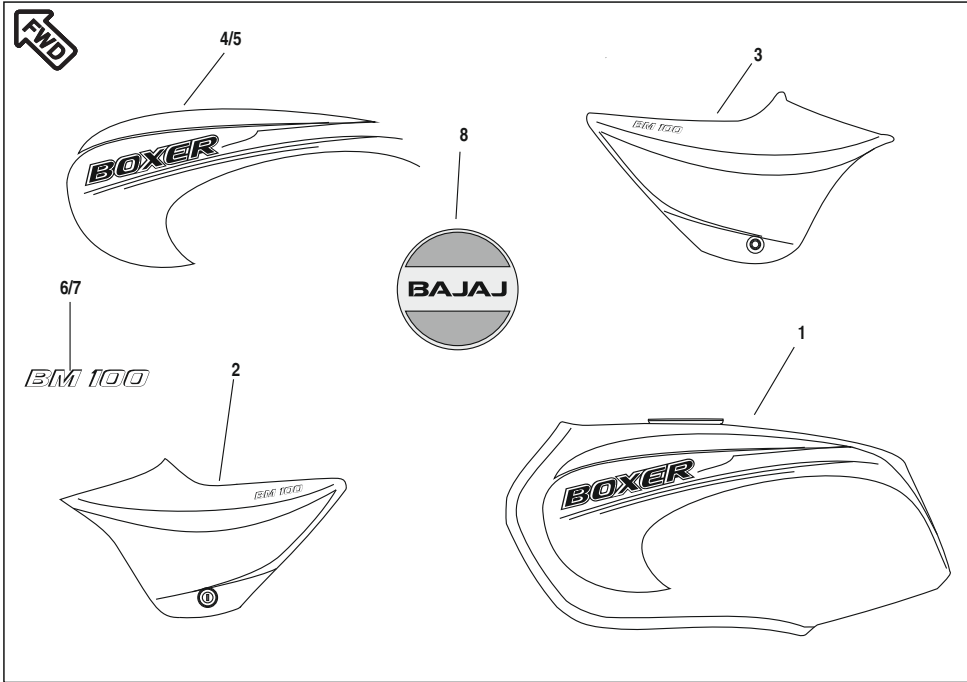

No.	Part No.	Description	Qty/ Veh.	Remarks
1	DM 7101 1G	Tank Fuel with Decal	1	Crescent Blue
	DM 7101 2V	Tank Fuel with Decal	1	C Wine Red
	DM 7106 22	Tank Fuel with Decal	1	Jet Black
	DM 7105 X4	Tank Fuel with Decal	1	Flame Red
2	DM 7301 1G	Side Cover LH + New Decal	1	Crescent Blue
	DM 7301 2V	Side Cover LH + New Decal	1	Cock Tail Wine Red
	DM 7307 22	Side Cover LH + New Decal	1	Jet Black
	DM 7305 X4	Side Cover LH + New Decal	1	Flame Red
3	DM 7302 1G	Side Cover RH + New Decal	1	Crescent Blue
	DM 7302 2V	Side Cover RH + New Decal	1	Cock Tail Wine Red
	DM 7308 22	Side Cover RH + New Decal	1	Jet Black
	DM 7306 X4	Side Cover RH + New Decal	1	Flame Red
4	DM 1410 38	Decal Tank LH Red Body	1	Cocktail Wine Red
	DM 1410 40	Decal Tank LH Blue Body	1	Crescent Blue
	DM 1410 42	Decal Tank LH Black Body	1	Ebony Black

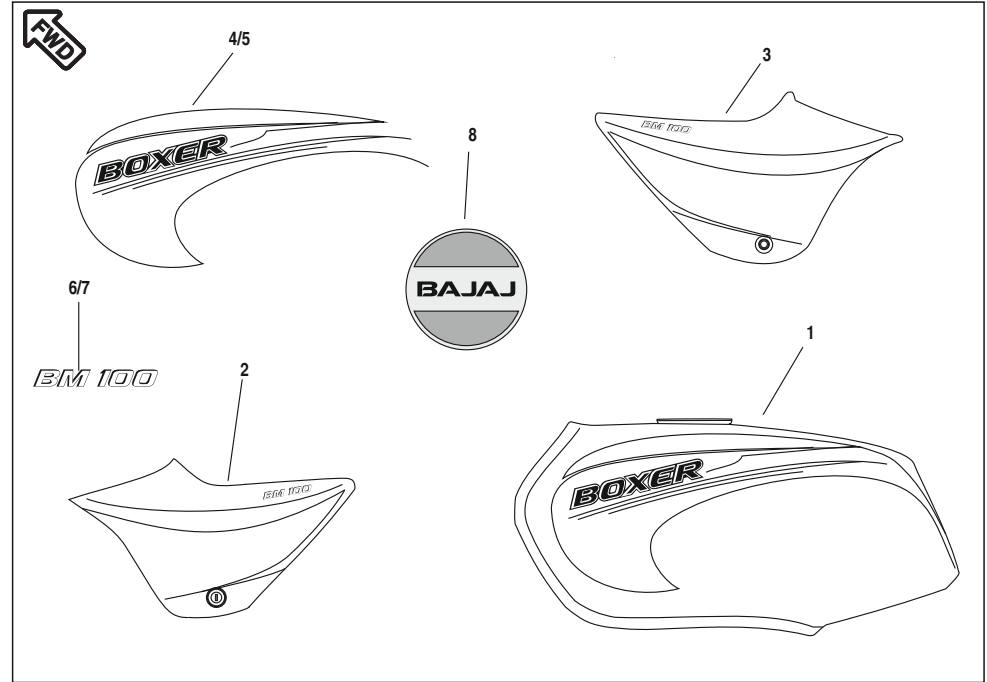

No.	Part No.	Description	Qty/ Veh.	Remarks
5	DM 1410 39	Decal Tank RH Red Body	1	Cocktail Wine Red
	DM 1410 41	Decal Tank RH Blue Body	1	Crescent Blue
	DM 1410 43	Decal Tank RH Black Body	1	Ebony Black
6	DM 1611 52	Decal Side Cover LH	1	For All Colors
7	DM 1611 53	Decal Side Cover RH	1	For All Colors
8	DU 1011 88	Decal Clutch Cover	1	

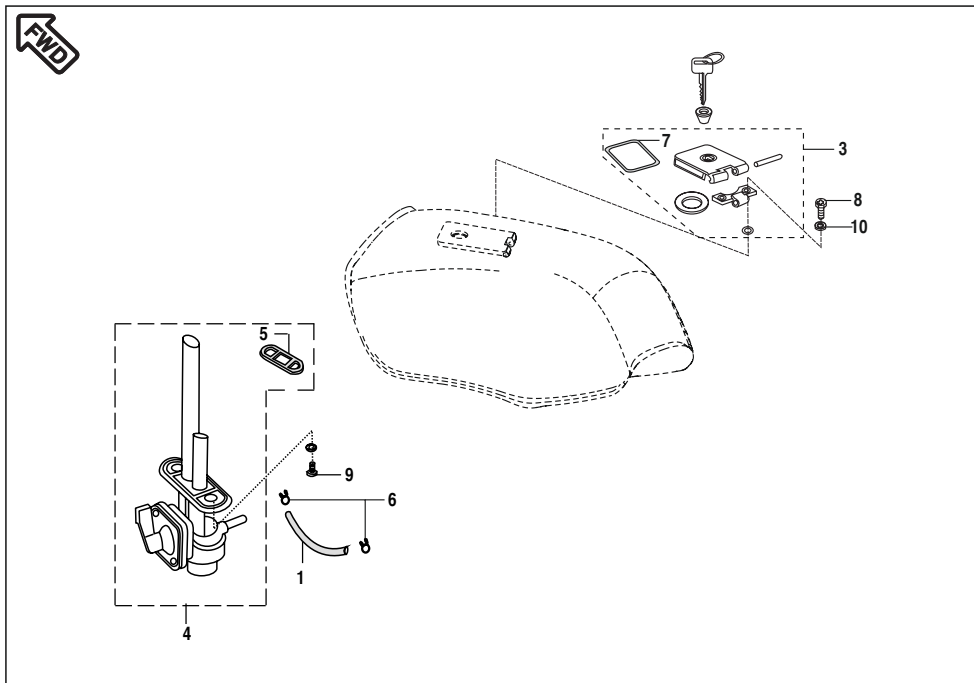

No.	Part No.	Description	Qty/ Veh.	Remarks
1	DU 1410 41	Tube Fuel	1	
2	DF 1810 24	Lock set Assly. (3 IN 1)	1	(N.I.)
3	DF 1411 20	Cap Assly. Tank	1	
4	DU 1412 28	Tap Assly.	1	
5	30 1410 39	Packing For Tap	1	
6	33 1410 08	Clamp Tube	2	
7	30 1410 52	Packing (For Cap)	1	
8	39 0761 01	Screw Pan Cross	2	
9	DD 1412 27	Bolt Flanged	2	
10	30 1410 31	O Ring	2	

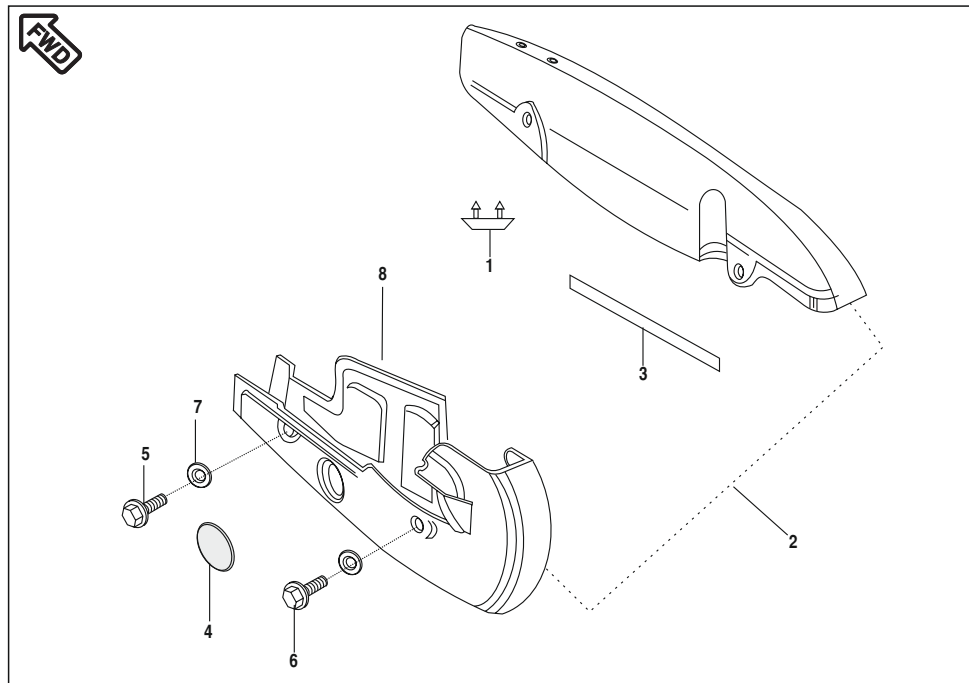

No.	Part No.	Description	Qty/ Veh.	Remarks
1	30 16 1271	Rubber Pad	1	N.S
2	52 DM01 59	Kit Chain Case	1	
3	DF 1614 15	Trim case chain	1	N.S
4	DF 1614 16	Rubber Cap	1	
5	39 2475 04	Flanged Bolt	2	
6	39 2473 04	Flanged Bolt	2	
7	39 1211 11	Washer plain	1	For case chain

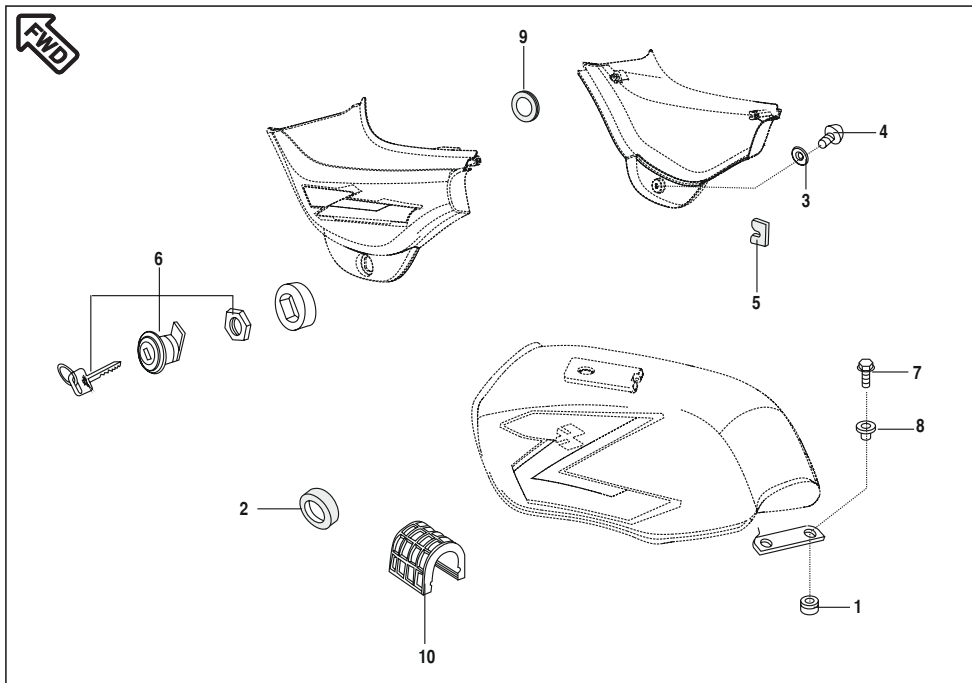

No.	Part No.	Description	Qty/ Veh.	Remarks
1	DF 1411 29	Damper	1	N.S
2	30 1611 69	Grommet	2	
3	39 1789 24	Washer Nylon	1	
4	DG 1611 21	Screw	1	
5	DU 1611 02	Damper	1	
6	DF 1810 24	Lock set (4 in 1)	1	N.I.
7	DL 1410 35	Flange Bolt	1	N.S
8	39 1054 11	Plain Washer	1	
9	DL 1610 17	Damper - cover side	2	
10	DF 1411 30	Damper	1	N.S

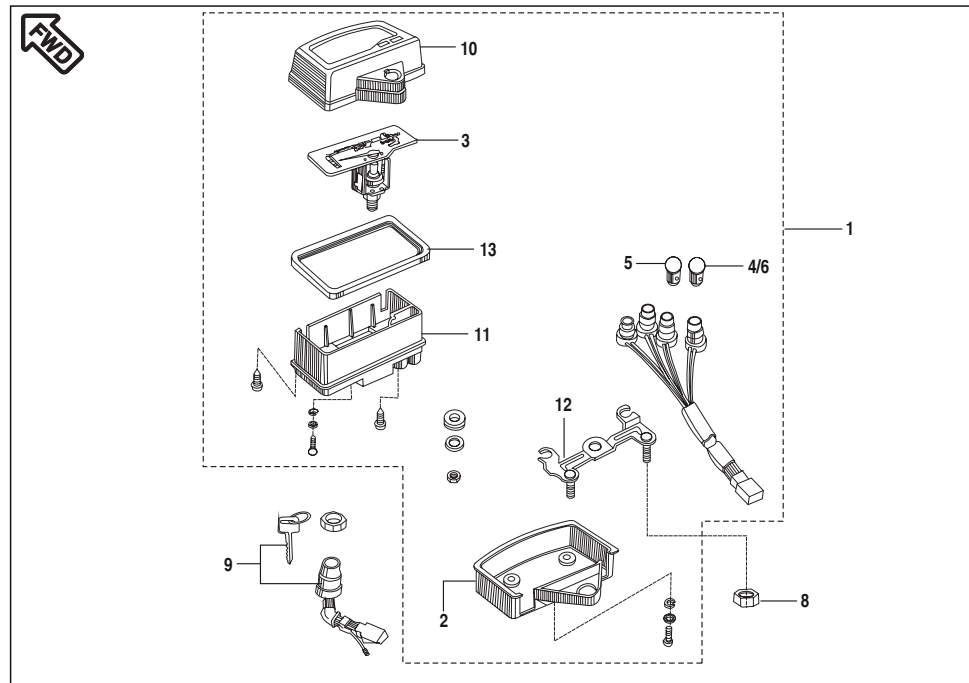

No.	Part No.	Description	Qty/ Veh.	Remarks
1	31 1910 12	Meter Assly/ Lamp	1	
2	31 1910 21	Cover Meter Lower Black	1	
3	31 1910 18	Speedometer	1	
4	DJ 2010 72	Lamp 12V 5W	1	
5	30 2010 84	Lamp 12V 2W	2	
6	DJ 2010 72	Lamp 12V 5W	1	
7	DF 1810 24	Lock Set	1	N.I. 3 in one
8	39 0798 15	Nut	1	
9	DF 1810 24	Lock Set Steering, P.Tank, Side cover, DC Ing.	1	
10	31 1910 17	Cover meter case upper	1	Black
11	31 1910 20	Cover (white)	1	
12	31 1910 14	Bracket Meter	1	
13	31 1910 19	Gasket Rubber	1	

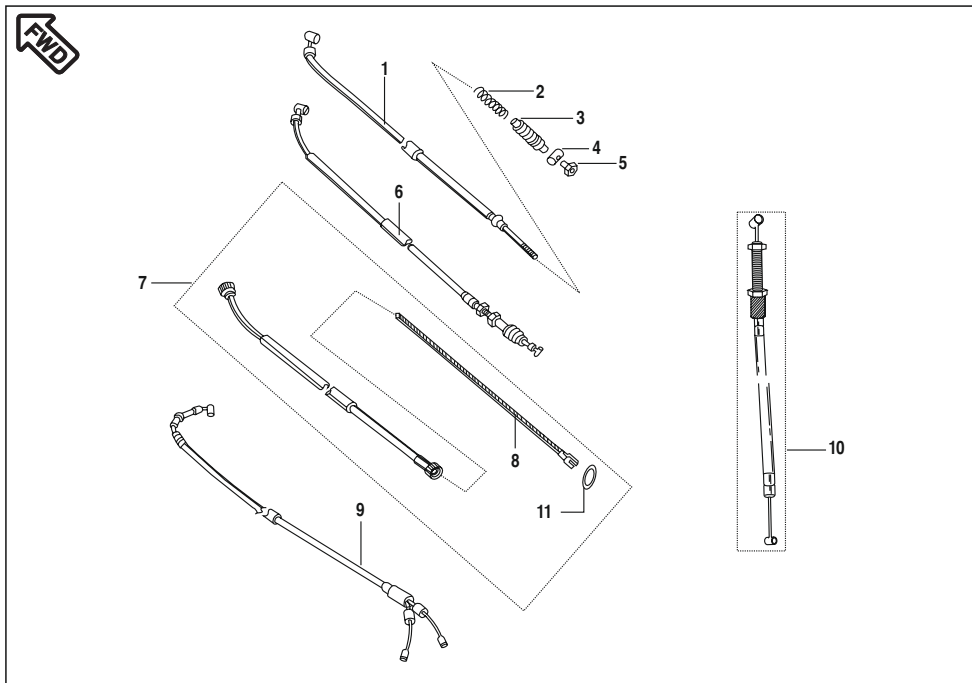

No.	Part No.	Description	Qty/ Veh.	Remarks
1	DU 1910 41	Cable Brake (FR)	1	
2	30 19 1070	Spring	1	
3	30 19 1069	Dust Seal	1	
4	30 19 1071	Rod End	1	
5	30 19 1072	Adjusting Nut	1	
6	DM 1910 17	Cable Clutch	1	
7	DU 1910 13	Cable Speedometer	1	Old New
8	DZ 1910 14	Cable Speedometer	1	
8	DZ 1910 19	Inner Cable Speedo	1	
9	DM 1910 05	Cable Throttle	1	
10	DM 1910 02	Cable starter	1	
11	39 1561 21	"O" Ring	1	

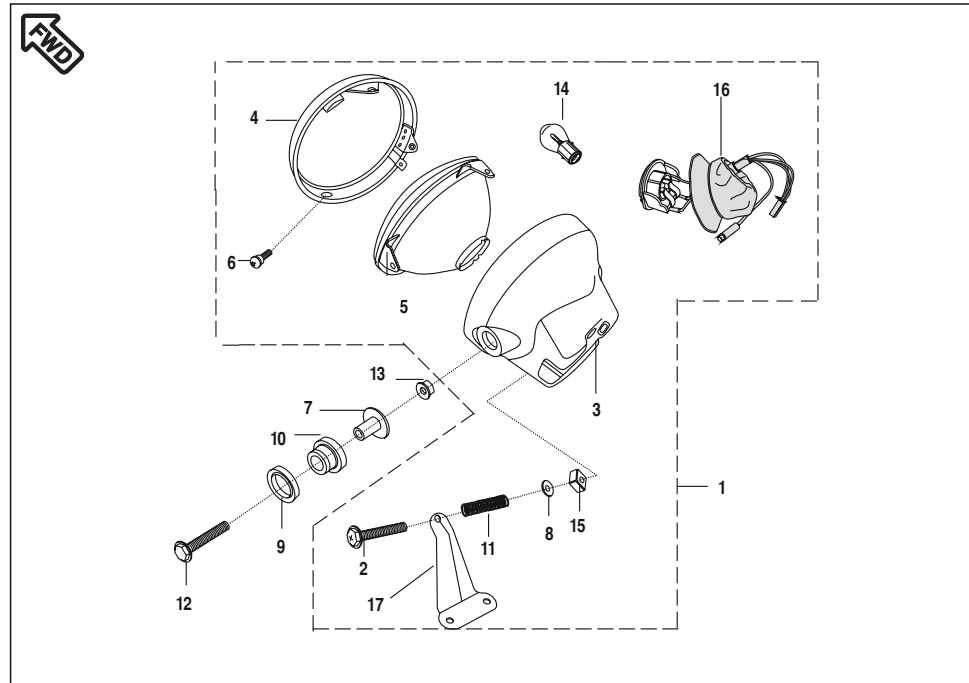

No.	Part No.	Description	Qty/ Veh.	Remarks
1	DM 2010 22	Head light assly with lamp	1	
2	DD 2010 45	Screw	1	N.S
3	DU 2010 57	Head Light Housing	1	
4	DJ 2010 46	Head Light Rim	1	
5	DJ 2010 51	Reflector with Lens	1	
6	DU 2010 29	Special Screw	2	
7	DU 2010 60	Collar	2	
8	DD 2010 47	Washer	1	N.S
9	DD 2010 10	Damper	2	
10	DD 2010 09	Damper	2	
11	DD 2010 46	Spring for Adjustment	1	N.S
12	39 1683 04	Flange Bolt	2	
13	39 2479 15	Flange Nut	2	
14	25 2010 09	Lamp 12 V 35/35 W	1	
15	DD 2010 48	Nut (Nylon)	1	N.S
16	DF 2010 58	Lamp Holder (Socket) Assly.	1	
17	DD 2010 17	Bracket Head Lamp	1	N.S

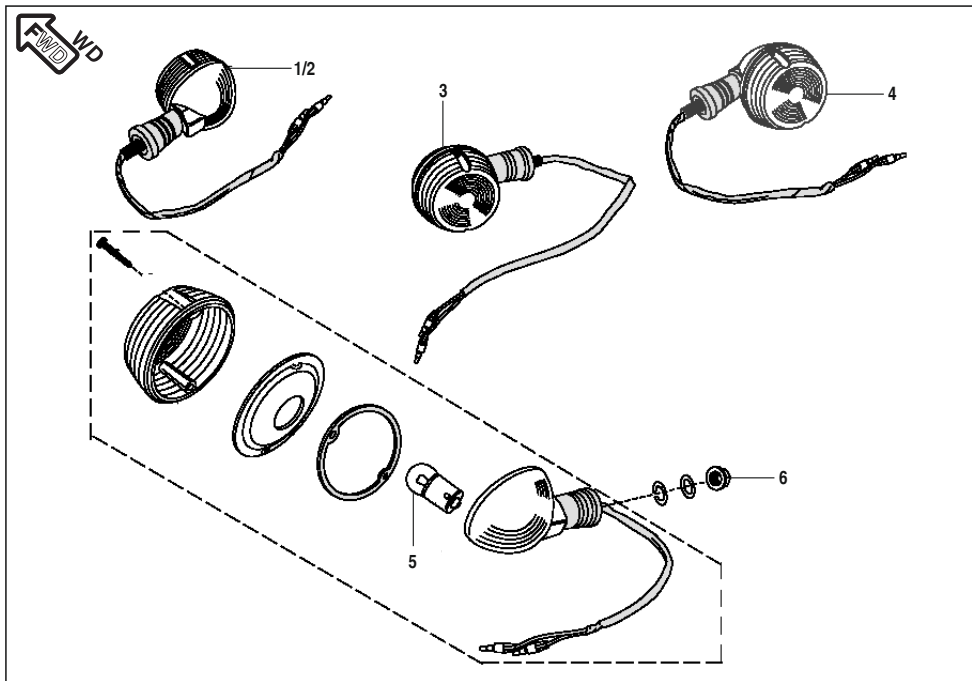

No.	Part No.	Description	Qty/ Veh.	Remarks
1	DM 2010 28	Dir. ind. Front RH with Lamp	1	
2	DM 2010 27	Dir. ind. Front LH with Lamp	1	
3	DM 2010 29	Dir. ind. Rear LH with Lamp	1	
4	DM 2010 30	Dir. ind. Rear RH with Lamp	1	
5	06 2010 83	Lamp 12 V 10 W	4	
6	39 1225 15	Hex. Nut	4	

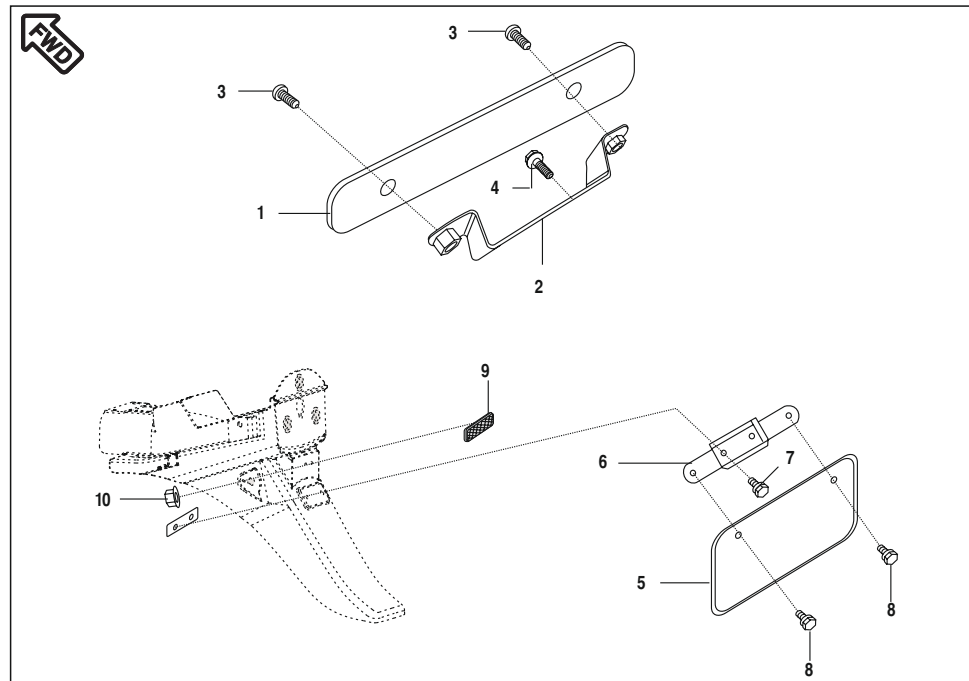

No.	Part No.	Description	Qty/ Veh.	Remarks
1	DP 1611 44	Front Number plate	1	
2	DF 1810 97	Bracket Front No. Plate	1	N.S
3	39 1783 01	Truss Screw	2	
4	39 2473 04	Flanged bolt	2	
5	DP 1611 45	Number plate Rear	1	
6	DF 1612 48	Bracket No. Plate	1	
7	39 2476 04	Hex head bolt / Flange	2	
8	39 2475 04	Hex. bolt / Flange	2	
9	30 2010 69	Reflector Reflex	1	
10	39 2484 15	Flanged Nut	1	

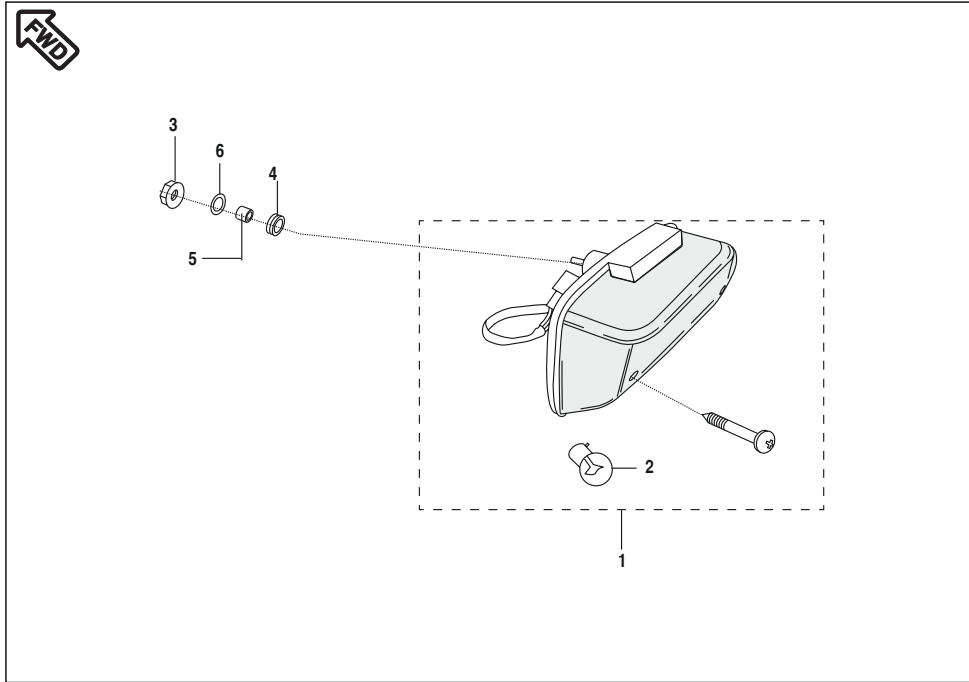

No.	Part No.	Description	Qty/ Veh.	Remarks
1	DF 2011 38	Tail Light Assly. with lamp	1	For Mtg. Tail light
2	20 2010 29	Lamp 12 V, 21/5W	1	
3	39 2430 15	Hex Nut. / Flange	2	
4	DD 2010 11	Damper	2	
5	31 2010 01	Collar	2	
6	39 2429 11	Plain Washe	2	

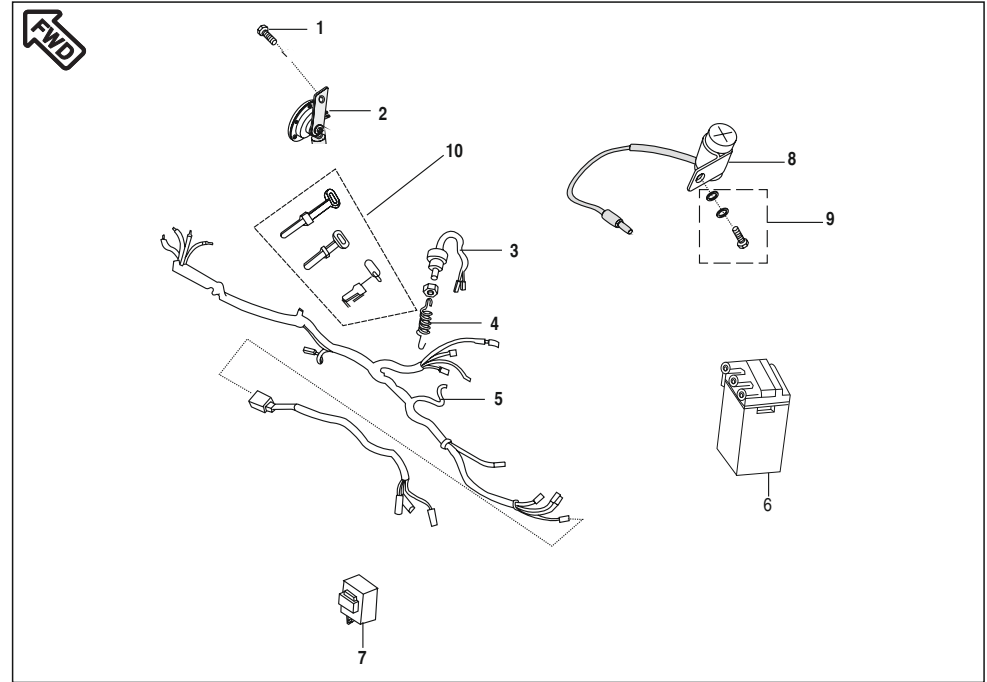

No.	Part No.	Description	Qty/ Veh.	Remarks
1	39 1940 04	Flanged Bolt	1	Nigeria Non Nigeria
2	JW 4016 00	Horn	1	
3	31 2010 79	Switch Rear Brake	1	
4	30 2010 74	Spring Brake Switch	1	
5	DM 2010 32	Wiring Harness	1	
	DM 2010 33	Wiring Harness	1	
6	31 2010 27	Battery	1	
7	DS 2010 25	Relay assly.	1	
8	DU 2010 63	Capacitor Electrolytic	1	
9	39 2473 04	Hex Head Bolt / Flange	1	
10	30 1910 48	Band	3	

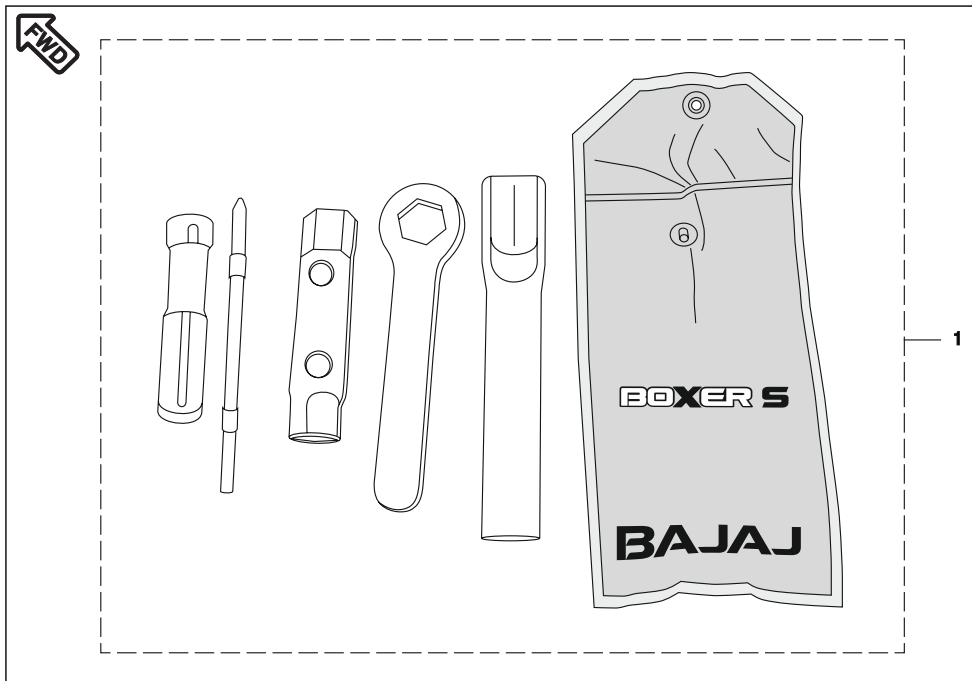

No.	Part No.	Description	Qty/ Veh.	Remarks
1	DM 2210 13	Tool Kit	1	

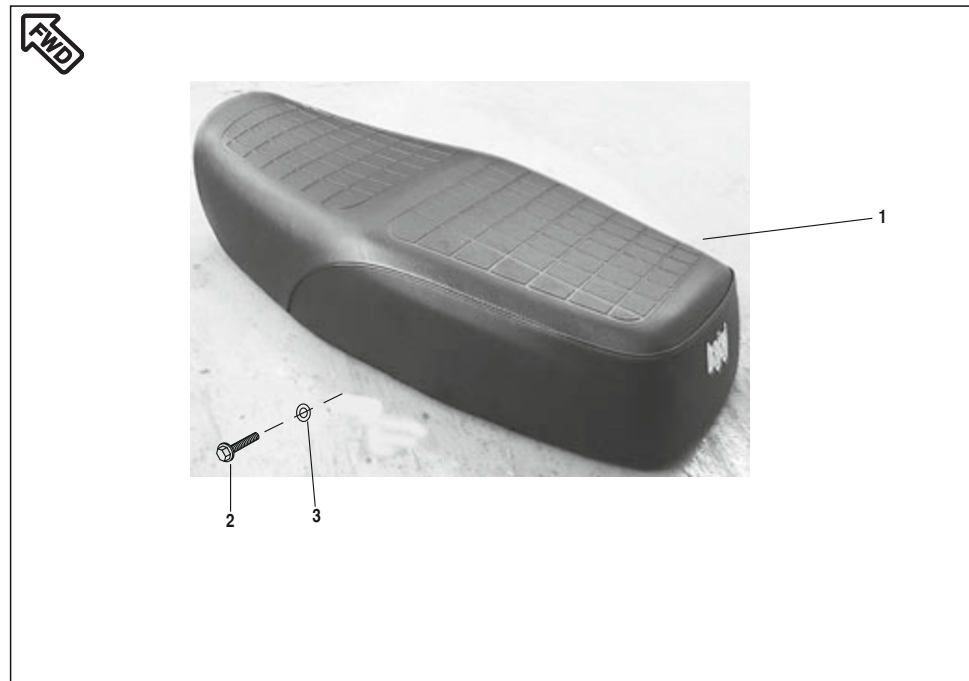

No.	Part No.	Description	Qty/ Veh.	Remarks
1	DM 2110 21 DM 2110 18	Seat assly. Seat Assly. Rear Hook + Front End Bolting	1	Nigeria
2	39 1802 04	Hex. Soc. Hd. Bolt	2	Non Nigeria
3	39 1211 11	Washer	2	N.S



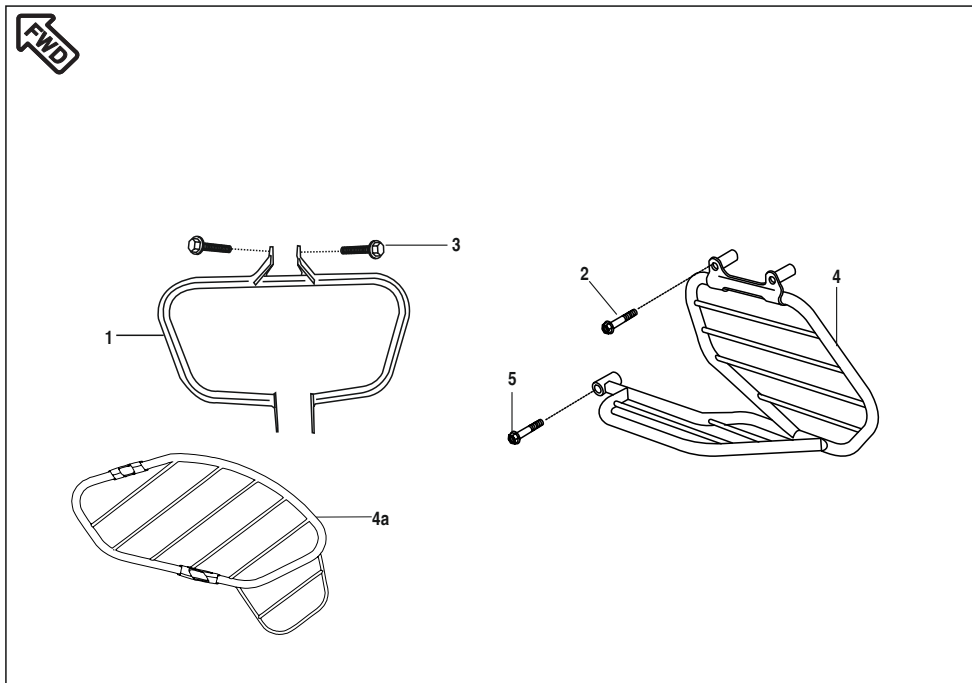

No.	Part No.	Description	Qty/ Veh.	Remarks
1	DZ 2210 03	Leg guard	1	For mounting Leg guard
2	39 1814 04	Bolt Flanged	1	
3	39 1940 04	Flanged Bolt	2	
4	DF 2210 54	Saree Guard	1	
4a	PF 2312 00	Saree Guard	1	
5	39 1608 04	Hex. soc. hd. bolt	2	

Sr. No.	Kit Part No.	Kit Description	Consisting of Following Parts		
			Part No.	Description	Qty./Kit
1	36DU1001	O Ring Kit	39102021	O Ring	2
			39256921	O Ring	1
2	36311008	Collet Seal Oil Kit	31101019	Collet	4
			39103519	Oil Seal	2
			31101045	Seat Spring	2
3	36311028	Valve Kit	DD101134	Valve Intake	1
			DD101135	Valve Exhaust	1
4	36311006	Chain Guide Kit	31101026	Guide Chain RH	1
			31101025	Guide Chain LH	1
5	36DU1004	Gear Lever Spring Kit	31101055	Spring	1
			31101054	Spring	1
			DU101084	Spring	1
6	36DU1007	Boss Kick Kit	30101233	Boss Kick	1
			30101234	Spring	1
			30101236	Ball Steel	1
			30101235	Pin	1
			39085517	E - Type Circlip	1
7	36DU1201	Air Filter Kit	DM121007	O Ring for Air Filter	1
			DM121004	Cap	1
			01110609	Plain Washer	4
			39083001	Screw Pan cross	4
			DF161426	Bolt Steeped Flanged	2
8	36311803	Bearing Cone kit	DH181025	Bearing Cone	1
			DH181026	Bearing race	1
			DH181024	Upper Bearing Race	1
			DH181023	Bearing Cone	1
9	36DF1701	Rubber - Inner Bush Kit	30171030	Rubber Bush	4
			30171031	Inner Bush	4
10	36DU1601	Chain Case Kit	52DU0175	Case Chain Upper Assly.	1
			52DU0176	Case Chain Lower Assly.	1
11	36DU1503	Gear Meter Screw Kit	31151064	Speedo Gear (22T)	1
			30151041	Gear Meter Screw	1
12	36DM0001	Chain Sprocket Kit	DF151023	Chain (112 Links)	1
			DJ151018	Sprocket (42 T)	1
			DX101052	Sprocket O/P	1
13	36DU1506	Rear Wheel Bearing Kit	39236220	Bearing Ball :- 12 X 37 X 12	1
			39239620	Bearing Ball :- 12 X 32 X 10	1
14	36DU1901	Cable Adjuster Kit	30191017	Nut	2
			DD191147	Screw	2
15	36DU1202	Idling Screw Kit	DU121024	Screw Idling (Stop Screw)	1

KIT LIST



Sr. No.	Kit Part No.	Kit Description	Consisting of Following Parts		
			Part No.	Description	Qty./Kit
16	36DU1203	Air Control Screw Kit	DD121176	Spring - Idling Screw	1
			DU121025	Screw - Air (Adjust)	1
			DD121178	Spring - Screw Air	1
17	36DU1204	Gasket O ring Kit for Carb.	DD121170	Gasket - Float Chamber	1
			DU121023	Gasket Top	1
18	36DU1205	Carburettor Float Pin Kit	DD121168	Valve complete Float	1
			DU121015	Float Complete	1
19	36DU1206	Carburettor Holder/Jet Kit	DU121018	Needle Jet	1
			DU121012	Holder - Needle Jet	1
			DU121013	Main Jet	1
			DU121014	Slow Jet complete	1
			DU121021	Spring - Valve throttle	1

AMENDMENT SHEET (PARTS ADDED)



Page no.	Fig. no.	Old part no.	New part no.	Description	Updation date	Remarks
16	16	----	DD111046	TPS ASSLY	30-03-15	MAIL FROM VAIBHAV SIR CORRECTION ALT UPDATED ADDITION
36	13	DF181077	DD181205	TYRE WITH TUBE FR	05-11-15	
20	18	DX111005	DF111016	MAGNETO ASSLY	09-08-16	
20	19	-----	31111056	COIL ASSEMBLY - EXCITOR	15-11-16	

AMENDMENT SHEET (PARTS DELETED)



Sr. No.	Part No.	Description	Qty.	Page No.	Fig. No.

Part Index



Part No.	Figure No.	Page No.
1100610	2	5
1110609	11	24
1170110	11	9
1170111	7	9
1170111	1	10
14151021	20	28
16151066	1	25
16151066	1	26
20201029	2	48
22150241	7	15
22150435	12	24
25201009	14	45
28101107	4	5
28101107	16	5
28101195	2	14
28101214	9	14
30101015	12	10
30101096	7	14
30101142	6	13
30101154	5	15
30141015	15	10
30141031	10	40
30141039	5	40
30141052	7	40
30151005	24	30
30151005	24	32
30151008	16	30
30151011	15	29
30151038	13	27
30151038	17	30
30151038	17	32
30151042	25	28
30151063	11	29
30151069	17	28
30151069	13	29
30151069	13	31
30151075	12	29
30151078	26	30
30151079	27	30
30151081	3	29
30151095	15	33
30151105	14	29
30151118	23	28
30161157	8	23

Part No.	Figure No.	Page No.
30161158	7	23
30161169	2	42
30161271	1	41
30171018	9	22
30181023	20	37
30181025	5	36
30181026	4	36
30181029	11	36
30191031	8	33
30191035	9	33
30191036	14	33
30191038	4	33
30191038	13	33
30191048	8	34
30191048	10	49
30191069	3	44
30191070	2	44
30191071	4	44
30191072	5	44
30201069	9	47
30201074	4	49
30201084	5	43
31101006	2	1
31101007	10	1
31101008	4	1
31101014	1	18
31101018	6	2
31101033	6	3
31101038	11	15
31101039	10	15
31101040	16	15
31101041	8	15
31101051	2	7
31101056	8	10
31101061	4	12
31101062	1	12
31101067	4	13
31101104	4	2
31101108	10	8
31101109	11	8
31101113	5	12
31101137	16	14
31101148	13	14
31101175	16	1

## Part Index

**BOXER**  
*EM 100*

Part No.	Figure No.	Page No.
31101191	1	7
31101192	5	7
31101295	3	12
31111056	19	20
31111058	9	20
31121029	5	17
31151001	20	32
31151004	3	27
31151011	15	27
31151014	22	28
31151018	12	31
31151021	10	31
31151023	15	31
31151024	16	32
31151026	9	29
31151026	9	31
31151027	26	32
31151028	27	32
31151029	3	31
31151030	25	30
31151030	25	32
31151036	12	27
31151037	18	32
31151060	18	28
31151060	14	31
31161007	13	17
31171006	7	22
31171012	16	22
31181015	6	36
31181120	10	36
31191002	2	21
31191012	1	43
31191014	12	43
31191017	10	43
31191018	3	43
31191019	13	43
31191020	11	43
31191021	2	43
31201001	5	48
31201003	7	49
31201027	6	49
31201079	3	49
31201081	9	10
33141008	6	40

Part No.	Figure No.	Page No.
36311006	1	3
36311008	8	2
36311028	9	2
36314001	5	21
36314002	6	21
36314005	5	21
36DD4001	4	4
36DF1701	5	22
36DM0001	1	29
36DU1001	1	1
36DU1004	3	8
36DU1007	6	15
36DU1201	6	17
36DU1202	7	16
36DU1203	8	16
36DU1204	5	16
36DU1205	6	16
36DU1206	4	16
36DU1503	4	27
36DU1505	1	29
36DU1505	1	31
36DU1506	7	29
36DU1506	7	31
36DU1901	14	34
36DU4003	1	31
36DU4017	1	31
39019811	2	33
39019811	23	35
39020111	8	22
39024211	25	28
39024811	2	9
39024811	6	22
39024811	7	27
39029215	4A	22
39042215	5	23
39042215	21	35
39045411	17	22
39055302	18	22
39070201	5	2
39070201	7	10
39070311	10	10
39070815	11	33
39071111	13	22
39071111	7	24

## Part Index

**BOXER**  
*EM 100*

Part No.	Figure No.	Page No.
39071215	1	22
39071411	3	22
39071411	21	32
39072504	22	35
39073712	2	22
39073817	14	15
39074501	14	20
39074601	5	8
39074801	10	3
39075301	2	19
39076101	8	40
39077504	10	27
39077504	19	32
39078708	10	23
39078912	12	33
39078912	17	37
39079415	4	29
39079415	4	31
39079708	7	33
39079815	16	28
39079815	6	29
39079815	6	31
39079815	8	43
39080511	6	33
39080708	10	33
39080808	1	33
39081715	8	24
39083001	7	34
39084001	21	28
39090012	26	28
39097804	2	31
39098004	10	14
39098517	5	4
39098608	3	17
39098717	4	6
39098815	8	29
39098815	8	31
39099206	6	7
39099311	9	15
39099511	13	15
39099906	11	3
39099906	6	9
39099906	8	12
39099906	3	13

Part No.	Figure No.	Page No.
39099906	4	19
39100006	12	1
39100006	1	4
39100320	5	20
39100820	6	10
39101321	5	19
39101321	19	28
39101721	14	1
39101721	2	3
39101921	2	12
39102121	5	1
39102304	3	11
39102821	6	20
39104119	5	13
39104219	4	20
39104319	4	10
39105006	2	10
39105315	11	14
39105411	8	42
39105515	1	5
39105604	4	9
39106204	4	11
39106204	15	16
39106604	3	10
39107404	7	12
39107404	3	34
39107504	11	10
39107504	10	13
39107801	1	19
39108019	5	10
39121111	7	41
39121111	3	51
39122515	1	9
39122515	10	22
39122515	6	46
39128321	3	16
39155304	10	20
39155604	13	21
39156121	11	44
39160804	5	52
39165911	7	20
39167304	3	1
39168004	9	17
39168304	12	45

## Part Index

**BOXER**  
*EM 100*

Part No.	Figure No.	Page No.
39169901	8	5
39178301	3	47
39178924	11	17
39178924	3	42
39179021	14	3
39180204	2	51
39181304	18	37
39181404	2	52
39186420	5	9
39194004	1	49
39194004	3	52
39198104	15	6
39199404	2	8
39213421	8	13
39214704	10	12
39219908	14	5
39220011	12	5
39222204	8	21
39222204	1	24
39224020	5	29
39224020	5	31
39240320	12	14
39240701	10	17
39242911	6	48
39243015	3	48
39244704	19	30
39245504	19	21
39246904	10	21
39247304	1	21
39247304	14	24
39247304	6	41
39247304	4	47
39247304	9	49
39247404	8	8
39247504	5	41
39247504	8	47
39247604	7	47
39247915	13	45
39248104	3	23
39248104	14	23
39248304	3	24
39248415	13	24
39248415	10	47
39256611	21	30

Part No.	Figure No.	Page No.
39260011	3	14
39268020	1	27
39268120	5	27
39270004	17	21
39270204	3	9
39270204	9	21
39270411	12	8
39276415	14	22
52DM0086	9	12
52DU0104	1	8
52DU0104	6	8
52DU0175	2	41
52DU0176	8	41
52DZ0046	12	22
52DZ0047	15	22
59040025	1	15
59150005	11	21
6201083	5	46
DD101007	2	4
DD101062	9	3
DD101101	13	10
DD101106	7	8
DD101254	3	15
DD101264	2	15
DD101309	1	6
DD101318	15	20
DD101325	7	13
DD101343	13	1
DD101347	6	1
DD101349	8	1
DD101350	7	1
DD101366	4	18
DD101407	7	3
DD101440	7	2
DD101475	16	6
DD101480	6	14
DD101481	15	1
DD101492	5	14
DD101493	8	14
DD101517	2	11
DD101521	18	1
DD111011	16	20
DD111012	17	20
DD111018	12	20

## Part Index

**BOXER**  
*EM 100*

Part No.	Figure No.	Page No.
Dd111046	16	16
DD111048	2	20
DD121171	11	16
DD141227	9	40
DD151008	11	27
DD151009	8	27
DD151014	16	33
DD151015	18	30
DD161051	4	24
DD161053	15	21
DD161078	17	33
DD181011	19	37
DD181031	2	36
DD181034	3	36
DD181090	25	37
DD181091	24	37
DD181205	13	36
DD201009	10	45
Dd201010	9	45
DD201011	4	48
DD201017	17	45
DD201045	2	45
DD201046	11	45
DD201047	8	45
DD201048	15	45
DD201170	11	34
DE181031	8	36
DF101055	2	2
DF111015	1	20
Df111016	18	20
DF111020	3	20
DF111040	13	20
DF121003	3	19
DF121023	1	17
DF121025	2	17
DF141120	3	40
DF141129	1	42
DF141130	10	42
DF151003	2	27
DF151005	2	26
DF151006	3	26
DF151023	28	30
DF151023	28	32
DF161102	4	23

Part No.	Figure No.	Page No.
DF161104	5	24
DF161168	16	21
DF161242	9	24
DF161245	10	24
DF161248	6	47
DF161413	1	23
DF161415	3	41
DF161416	4	41
DF161425	2	23
DF181024	18	21
DF181024	2	40
DF181024	6	42
DF181024	7	43
DF181024	9	43
DF181052	4	21
DF181083	16	37
DF181085	12	36
DF181090	3	21
DF181091	17	35
DF181092	18	35
DF181097	2	47
DF181117	1	34
DF191020	2	24
DF191026	9	34
DF191027	12	34
DF191066	10	34
DF201053	4	34
DF201058	16	45
DF201138	1	48
DF221007	15	34
DF221037	27	35
DF221054	4	52
DG101498	9	9
DG101498	12	10
DG121002	15	17
DG151022	9	25
DG161121	4	42
DG161124	11	23
DH101066	13	5
DH101067	15	5
DH101195	9	5
DH101430	6	4
DH121101	13	16
DH121102	14	16

## Part Index

**BOXER**  
*EM 100*

Part No.	Figure No.	Page No.
DH121103	7	17
DH161194	16	23
DH171019	22	30
DH171019	22	32
DJ151018	23	30
DJ201046	4	45
DJ201051	5	45
DJ201072	4	43
DJ201072	6	43
DK141041	15	10
DL141035	7	42
DL161017	9	42
DL161048	6	23
DL181080	1	36
DM101098	4	7
DM101099	8	7
DM101114	12	6
DM101139	6	12
DM101140	9	13
DM121010	12	17
DM121014	14	17
DM141038	4	38
DM141039	5	39
DM141040	4	38
DM141041	5	39
DM141042	4	38
DM141043	5	39
DM151005	28	32
DM151008	4	26
DM151009	23	32
DM151024	10	26
DM151027	14	25
DM151027	11	26
DM151028	7	25
DM151029	4	25
DM151029	6	26
DM151032	20	30
DM161009	6	24
DM161120	7	21
DM161146	17	23
DM161147	18	23
DM161152	6	39
DM161153	7	39
DM171018	11	22

Part No.	Figure No.	Page No.
DM171025	4	22
DM171027	4	22
DM181028	21	37
DM181029	22	37
DM181030	23	37
DM181036	7	36
DM181038	15	36
DM181039	14	36
DM191002	10	44
DM191005	9	44
DM191010	3	33
DM191014	13	34
DM191015	24	35
DM191016	5	33
DM191017	6	44
DM201022	1	45
DM201027	2	46
DM201028	1	46
DM201029	3	46
DM201030	4	46
DM201032	5	49
DM201033	5	49
DM211018	1	51
DM211021	1	51
DM221001	8	17
DM221008	12	21
DM221013	1	50
DM71011G	1	38
DM71012V	1	38
DM710622	1	38
DM73011G	2	38
DM73012V	2	38
DM73021G	3	38
DM73022V	3	38
DM730722	2	38
DM730822	3	38
DP101155	13	6
DP101168	14	6
DP101340	7	7
DP101452	8	9
DP151027	10	29
DP151028	2	29
DP161144	1	47
DP161145	5	47

## Part Index

**BOXER**  
*EM 100*

Part No.	Figure No.	Page No.
DS151009	10	25
DS151010	11	25
DS151046	8	25
Ds151048	5	25
DS151048	7	26
DS151049	6	25
DS151049	8	26
DS151052	9	26
DS151053	12	25
DU101005	3	5
DU101010	11	5
DU101011	6	6
DU101038	12	15
DU101041	7	5
DU101045	15	15
DU101050	4	15
DU101056	4	3
DU101057	2	16
DU101058	17	1
DU101066	12	3
DU101067	13	3
DU101074	4	8
DU101075	12	9
DU101080	7	6
DU101081	3	7
DU101083	9	7
DU101085	13	9
DU101109	4	14
DU101113	13	8
DU101185	9	8
DU101188	8	39
DU101190	3	2
DU101191	1	2
DU101196	3	18
DU101206	2	18
DU101208	9	1
DU101213	11	6
DU101218	3	4
DU101220	14	9
DU101223	10	9
DU101225	3	3
DU101228	11	1
DU101228	9	16
Du101278	6	6

Part No.	Figure No.	Page No.
Du101279	2	6
Du101280	13	10
DU121005	1	11
DU121008	4	17
DU121009	1	16
DU121017	12	16
DU121028	10	16
DU141041	1	40
DU141228	4	40
DU151005	6	27
DU151009	11	31
DU151018	5	26
DU151025	2	25
DU151025	2	26
DU151026	3	25
DU151026	3	26
DU151027	23	32
DU151031	9	27
DU161032	9	23
DU161093	14	21
DU161094	14	21
DU161102	5	42
DU161146	12	23
DU161147	13	23
DU191013	7	44
DU191030	3	33
DU191031	25	35
DU191033	5	34
DU191033	26	35
DU191035	6	34
DU191041	1	44
DU201029	6	45
DU201057	3	45
DU201060	7	45
DU201062	11	20
DU201063	8	49
DX101035	14	14
DX101045	2	6
DX101046	10	6
DX101047	5	5
DX101048	3	6
DX101049	5	6
DX101050	9	6
DX101051	8	6

Part Index



Part No.	Figure No.	Page No.
DX101052	12	6
DX101053	10	5
DX101054	1	14
DX101055	15	14
DX151081	29	30
DX151081	29	32
DX161056	15	23
DZ101034	14	10
DZ101046	2	13
DZ101047	1	13
DZ101075	5	3
DZ111002	8	20
DZ151012	12	27
DZ151027	14	27
DZ191004	5	33
DZ191014	7	44
DZ191019	8	44
DZ221003	1	52
FA101334	6	5
FD181012	9	36
FD181019	19	35
FD181020	20	35
FD181030	2	34
FD181031	16	35
JA131606	24	28
JA621206	1	15
JB131223	15	31
JW401600	2	49
LAD00026	8	3

Part Index



Part No.	Figure No.	Page No.
----------	------------	----------

Part No.	Figure No.	Page No.
----------	------------	----------