

220
OIL COOLED

AVENGER DTS-I



220
OIL COOLED

AVENGER DTS-I

Bajaj Auto Limited
Akurdi Pune 411 035 India
Tel +91 20 27472851
Fax +91 20 27407385

Spare Parts Catalogue



We have pleasure in presenting the Spare Parts Catalogue for 'Avenger DTS-i 220cc' Motorcycle. This catalogue has been specially designed to assist you in selecting the correct parts for procurement to maintain 100% availability.

The Bajaj spares are subjected to the stringent quality control standards to ensure longer life of the vehicle. It is therefore necessary that only the Genuine Bajaj Spares are used.

In a continual effort to improve Performance and Efficiency of the vehicles, Specifications, Diagrams, Illustrations and Part Numbers can change without notice. Consequently, the description in this Spare Parts Catalogue cannot therefore be final and binding on us.

The modifications / alterations which are carried out after the issue of this catalogue, will be conveyed to you through our Service Circulars. You are requested to make necessary corrections in the Parts Catalogue as per the circulars so as to keep your catalogue up-to-date. This will ensure the appropriate and speedy delivery of the Spare Parts as the order placed will bear the latest part numbers.

In case, if you need any technical assistance contact the concerned Regional Office or write to us on the following address :

Bajaj Auto Limited
Service Department

Akurdi, Pune 411 035 India

Phone : 020-27406557

Fax : 020-27407385

E-mail : service@bajajauto.co.in

All information contained in this manual is based on the latest product information at the time of publication. Bajaj Auto Limited accepts no liability for any inaccuracies or omissions in this publication, although every possible care has been taken to make it as complete and accurate as possible. All procedures and specifications subject to change without prior notice. The right is reserved to make such changes at any time without prior notice and without incurring an obligation to make such changes to product manufactured previously. Contact your authorized Bajaj Dealer for the latest information on product improvements incorporated after this manual was issued.

DOC. NO.: 7111119

REV. 00, JUNE 10

Instructions for using the Catalogue



- 1. How to Read the Catalogue :** Open the catalogue and from the pictorial index locate the group in which the part you want to find is present. Turn over to the concerned page number (as given by pictorial index). Now find out the figure of the part you wish to order. Write down the part number against that particular figure number from the text.

In case, if you have the part number and you need the other details, the part index can be used. The part index (at the end of the catalogue) will give you the figure and page number of the part you wish to order.

- 2. How to Order Spare Parts :** The part number and the description of the part required should be invariably mentioned in the order as per the catalogue text.

The latest part number as conveyed through our service circulars should only appear on the order. In case of ordering painted components, colour shade of the components should be mentioned.

The quantity shown against the part number is the quantity per vehicle for that group so that particular quantity should be multiplied by the number of sets required.

- 3. Part Number System:** We have used 8 digit system for part numbers. The model or hardware item is indicated by first two digits or alphanumeric, the next two or four digits indicate main group and the last four or two digits indicate serial number in main group or serial number or subgroup of fastener respectively. Thus the part numbers will be indicated by 2-2-4 or 2-4-2 digit system. Understanding this system will enable you to identify the spare parts easily.

- 4. Abbreviations :** The following abbreviations are used in this catalogue.

assly.	Assembly	V	Volts
N.I.	Not illustrated	W	Watts
C'case	Crankcase	accl.	Accelerator
Cyl	Cylinder	Comp.	Complete
o/s.	Over size	Fr	Front
Std.	Standard	L	Length
A/t.	Alternate	Rr	Rear
R.H.	Right hand	Hex.	Hexagonal
L.H.	Left hand	AR	As required

INDEX



No.	Description	Page No.
1	Cover Cylinder Head	1
2	Cylinder Head	2
3	Valve	3
4	Camshaft / Tensioner	4
5	Cylinder & Piston	5
6	Crankshaft	6
7	Balancer & Balancer Idler Gear	7
8	Transmission	8 & 9
9	Change Drum/ Shift Fork	10
10	Gear Change Mechanism	11
11	Engine Assly & Crankcase RH	12
12	Crankcase LH	13&14
13	Cover RH	15&16
14	Cover Magneto	17
15	Clutch	18&19
16	Oil Pump	20
17	Oil Cooler Assly.	21
18	Carburettor	22
19	Silencer Assly	23
20	Air Cleaner Comp.	24
21	Magneto/C.D.I./H.T.Coil	25&26
22	Starter Assly	27
23	Frame	28
24	Frame Fitting	29&30
25	Swing Arm	31
26	Rear Shock Absorber	32
27	Foot Rest	33
28	Mudguard Front & Rear	34
29	Stand	35
30	Tyre/ Tube & Wheel Rim	36
31	Front Hub	37
32	Rear Hub	38&39
33	Brake Pedal	40
34	Front Master Cylinder	41&42
35	Front Brake	43

No.	Description	Page No.
36	Handle Bar	44&45
37	Front Fork	46&47
38	Fuel Tank	48&49
39	Seat / Grip Frame Rear	
	Cover Grip Frame	50
40	Speedometer	51
41	Control Cables	52
42	Side Cover / Chain Cover	53
43	Guards	54
44	Head Light	55
45	Tail Light / Reflector Reflex	56
46	Indicator Light	57
47	Electrical Equipments	58
48	Ignition Switch	59
49	Tool Kit	60
50	Painted Parts	61&62
	Kits List	63
	Amendment Sheet (Part Added)	64
	Amendment Sheet (Part Deleted)	65
	Part Index	66

Pictorial Index

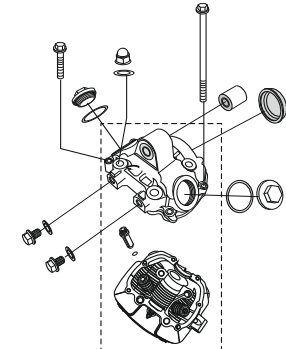
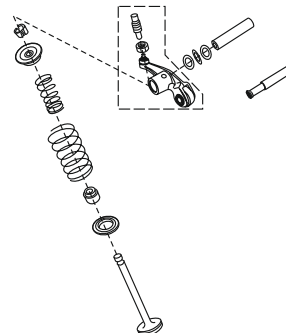
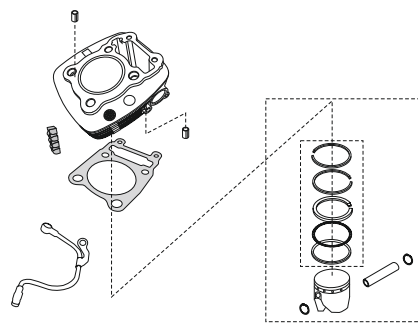
<p>PLATE NO. : 1 COVER CYLINDER HEAD</p>	<p>PAGE NO.: 1</p>
	
<p>PLATE NO. : 3 VALVE</p>	<p>PAGE NO.: 3</p>
	
<p>PLATE NO. : 5 CYLINDER AND PISTON</p>	<p>PAGE NO.: 5</p>
	

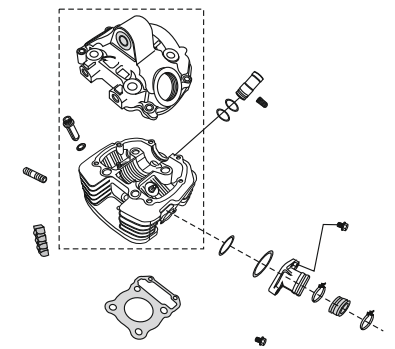
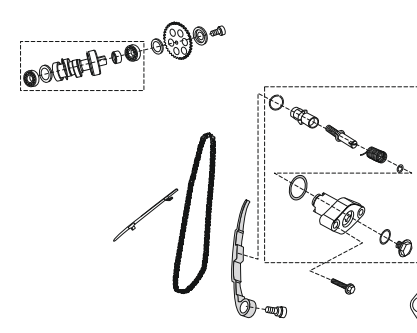
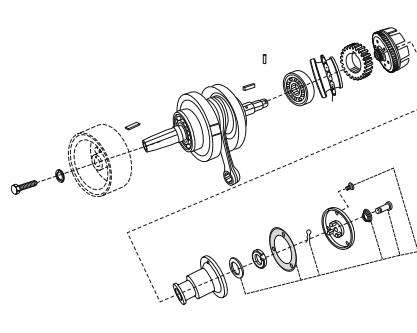
<p>PLATE NO. : 2 CYLINDER HEAD</p>	<p>PAGE NO.: 2</p>
	
<p>PLATE NO. : 4 CAMSHAFT / TENSIONER</p>	<p>PAGE NO.: 4</p>
	
<p>PLATE NO. : 6 CRANK SHAFT</p>	<p>PAGE NO.: 6</p>
	

Pictorial Index

PLATE NO. : 7
BALANCER & BALANCER IDLER GEAR

PAGE NO.:
7

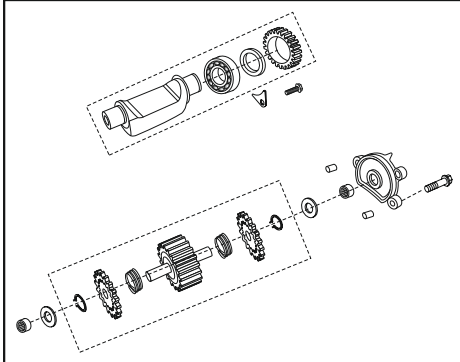

PLATE NO. : 9
CHANGE DRUM / SHIFT FORK

PAGE NO.:
10

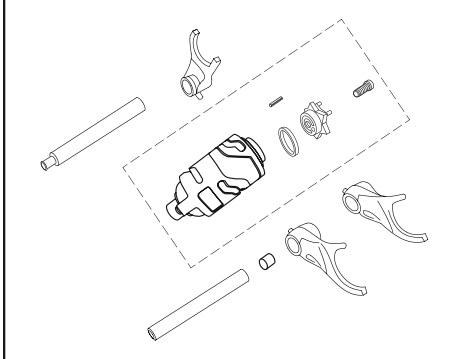

PLATE NO. : 11
ENGINE ASSLY. & CRANKCASE RH

PAGE NO.:
12

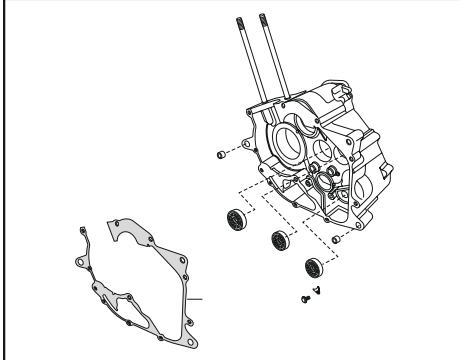

PLATE NO. : 8
TRANSMISSION

PAGE NO.:
8 & 9

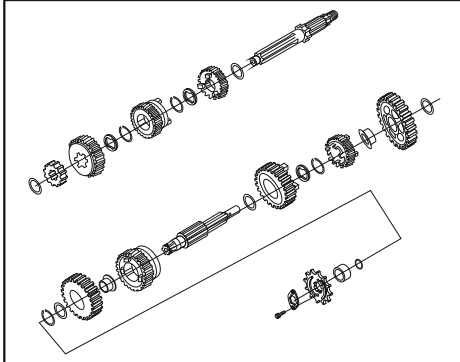

PLATE NO. : 10
GEAR CHANGE MECHANISM

PAGE NO.:
11

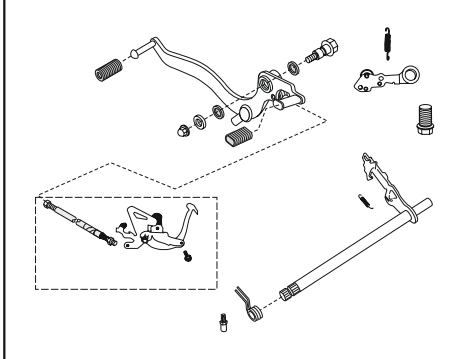
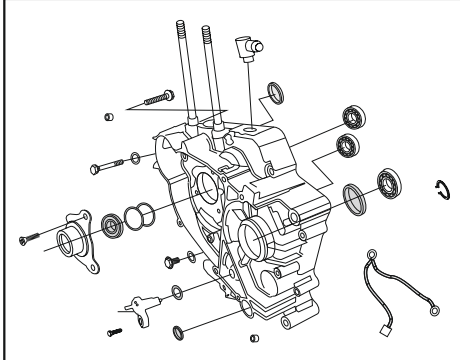

PLATE NO. : 12
CRANKCASE LH

PAGE NO.:
13 & 14



Pictorial Index

PLATE NO. : 13
COVER RH

PAGE NO.:
15 & 16

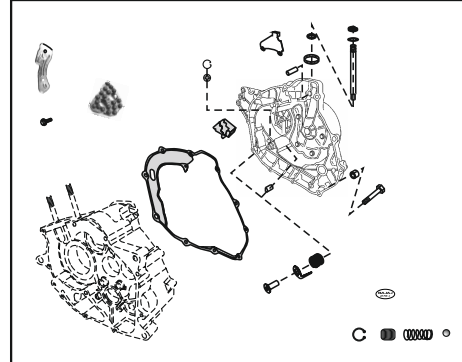

PLATE NO. : 15
CLUTCH

PAGE NO.:
18 & 19

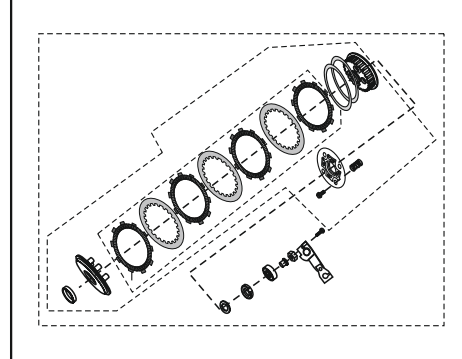

PLATE NO. : 17
OIL COOLER ASSEMBLY

PAGE NO.:
21

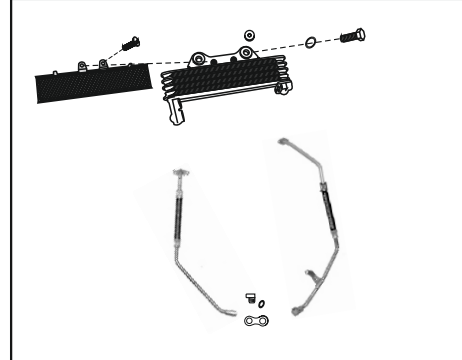

PLATE NO. : 14
COVER MAGNETO

PAGE NO.:
17

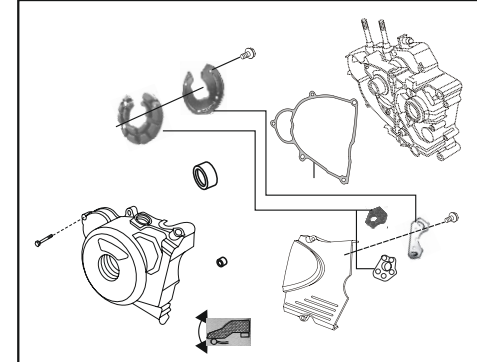

PLATE NO. : 16
OIL PUMP

PAGE NO.:
20

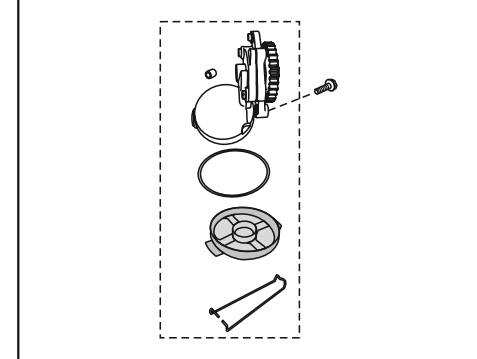
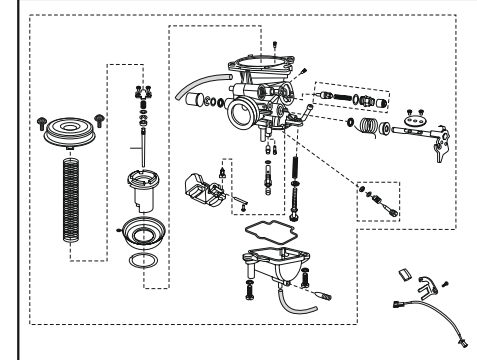

PLATE NO. : 18
CARBURETTOR

PAGE NO.:
22



Pictorial Index

PLATE NO. : 19
SILENCER ASSLY. PAGE NO.: 23

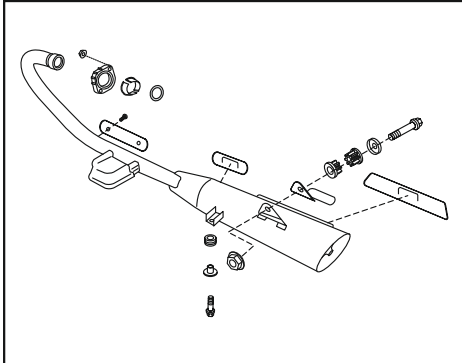

PLATE NO. : 21
MAGNETO / C.D.I. / H.T. COIL PAGE NO.: 26 & 27

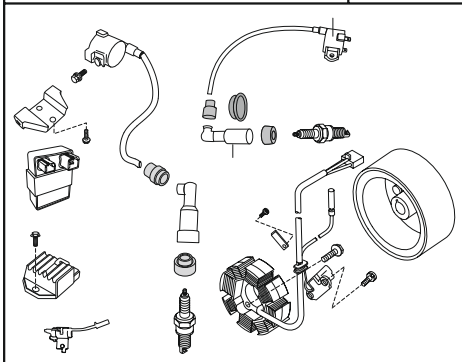

PLATE NO. : 23
FRAME PAGE NO.: 29

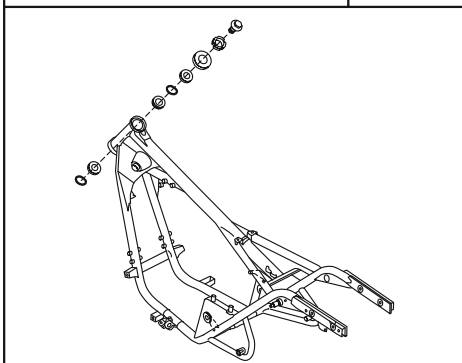

PLATE NO. : 20
AIR CLEANER COMP PAGE NO.: 24 & 25

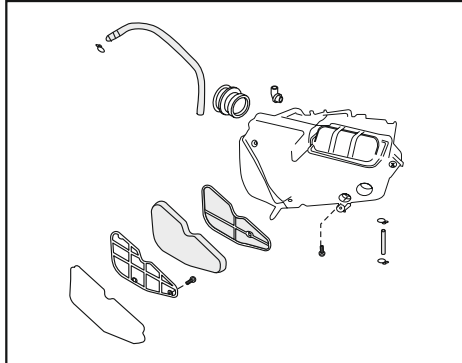

PLATE NO. : 22
STARTER MOTOR PAGE NO.: 28

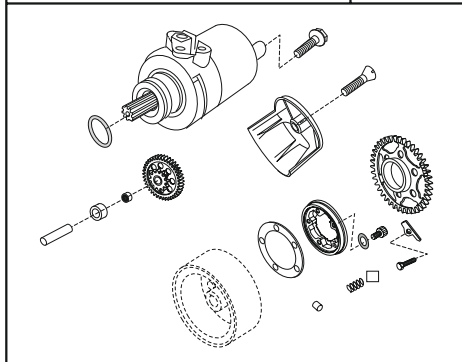
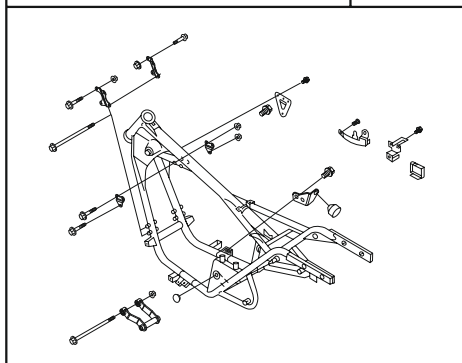

PLATE NO. : 24
FRAME FITTING PAGE NO.: 30 & 31



Pictorial Index

PLATE NO. : 25
SWING ARM PAGE NO.: 32

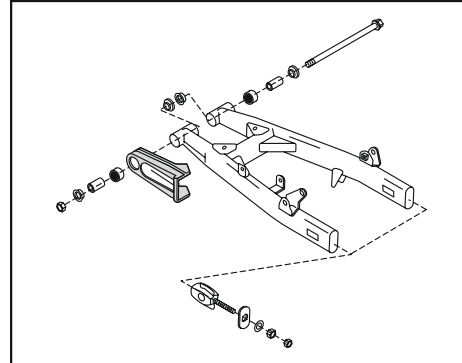

PLATE NO. : 27
FOOT REST PAGE NO.: 34 & 35

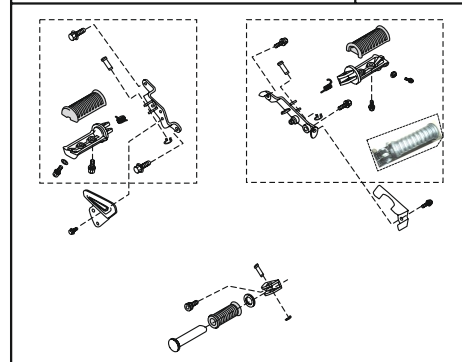

PLATE NO. : 29
STAND PAGE NO.: 37

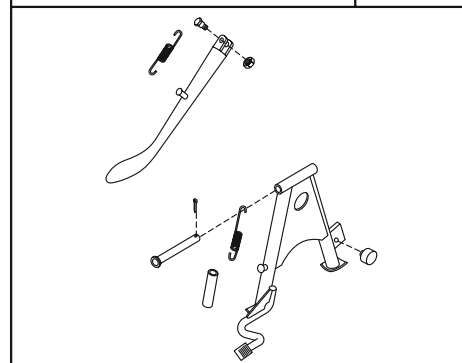

PLATE NO. : 26
REAR SHOCK ABSORBER PAGE NO.: 33

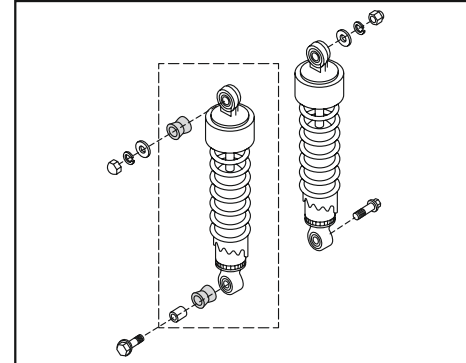

PLATE NO. : 28
MUDGUARD FRONT & REAR PAGE NO.: 36

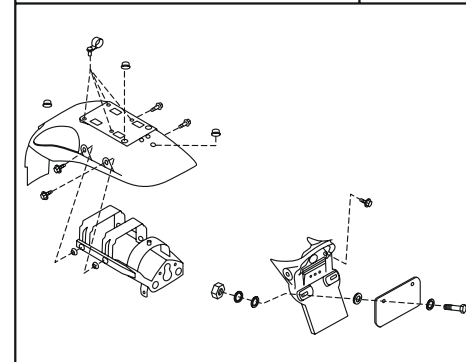
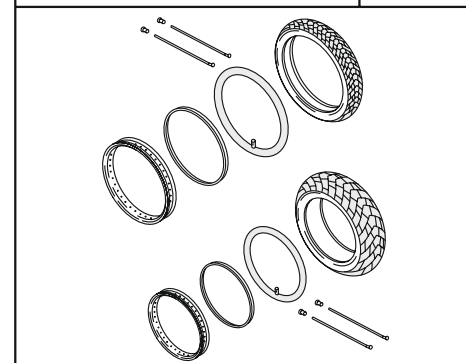

PLATE NO. : 30
TYRE, TUBE & WHEEL RIM PAGE NO.: 38



Pictorial Index

PLATE NO. : 31
FRONT HUB

PAGE NO.:
39

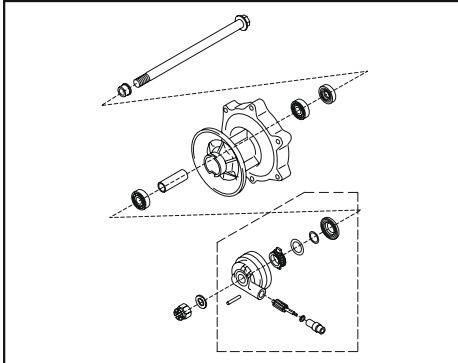

PLATE NO. : 33
BRAKE PEDAL

PAGE NO.:
42

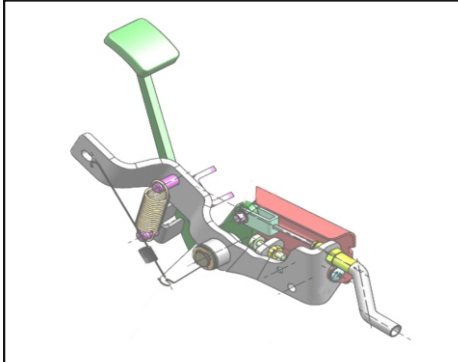

PLATE NO. : 35
FRONT BRAKE

PAGE NO.:
45

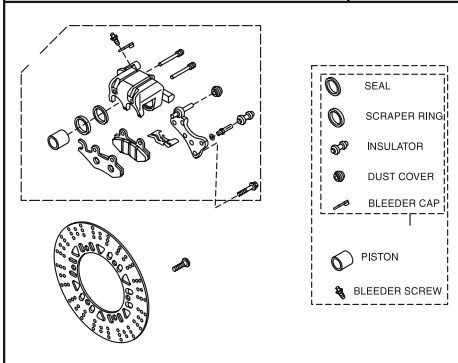

PLATE NO. : 32
REAR HUB

PAGE NO.:
40 & 41

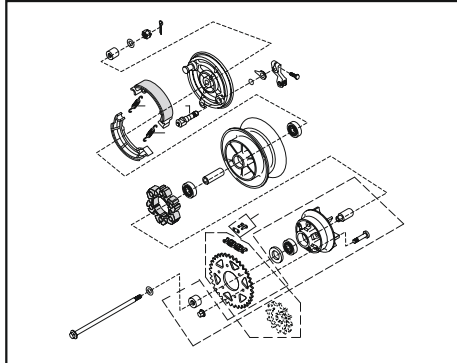

PLATE NO. : 34
FRONT MASTER CYLINDER

PAGE NO.:
43 & 44

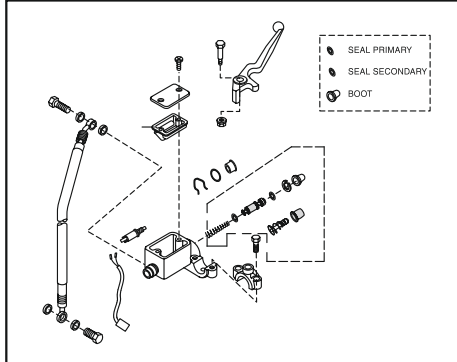
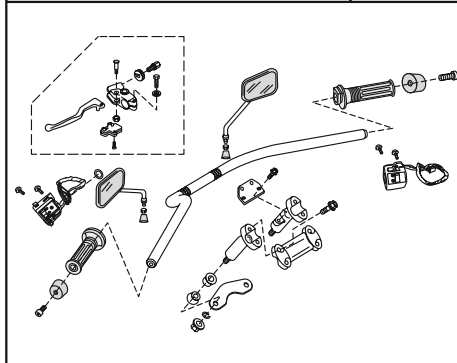

PLATE NO. : 36
HANDLE BAR

PAGE NO.:
46 & 47



Pictorial Index

PLATE NO. : 37
FRONT FORK

PAGE NO.:
48 & 49

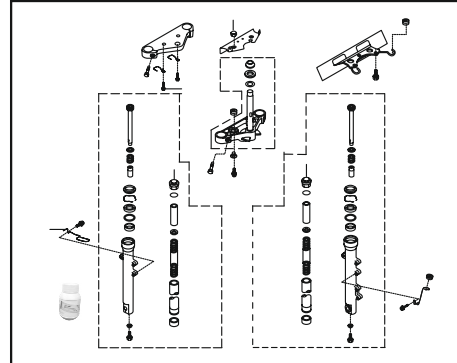

PLATE NO. : 39
SEAT/GRIP FRAME RR./COVER
GRIP FRAME

PAGE NO.:
52

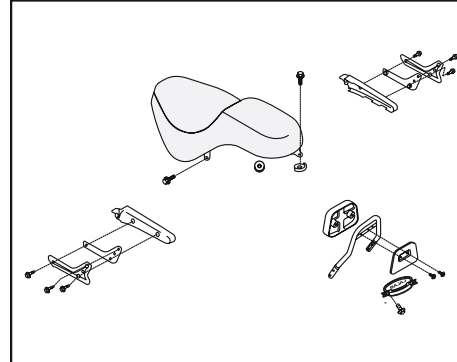

PLATE NO. : 41
CABLES

PAGE NO.:
54

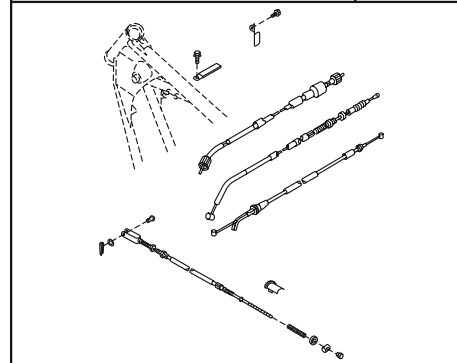

PLATE NO. : 38
FUEL TANK

PAGE NO.:
50 & 51

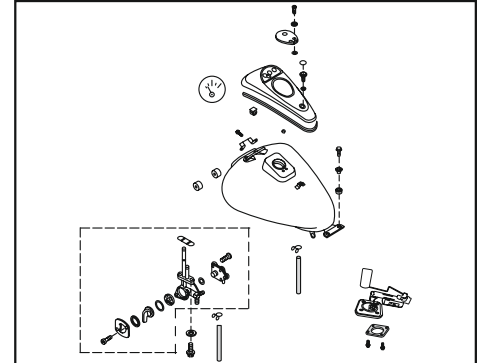

PLATE NO. : 40
SPEEDOMETER

PAGE NO.:
53

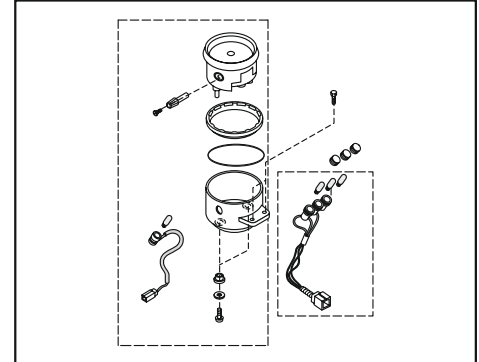
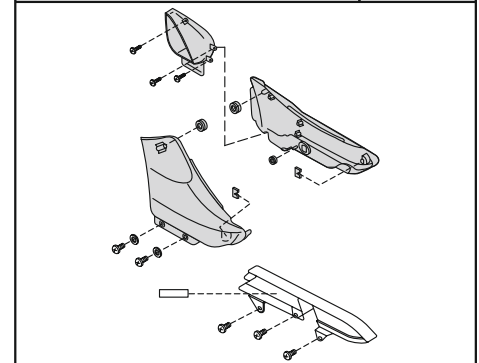

PLATE NO. : 42
SIDE COVERS / CHAIN COVER

PAGE NO.:
55



Pictorial Index

PLATE NO. : 43 GUARDS	PAGE NO.: 56
	
PLATE NO. : 45 TAIL LIGHT / REFLECTOR REFLEX	PAGE NO.: 58
	
PLATE NO. : 47 ELECTRICAL EQUIPMENT	PAGE NO.: 60
	

PLATE NO. : 44 HEAD LIGHT	PAGE NO.: 57
	
PLATE NO. : 46 INDICATOR LIGHT	PAGE NO.: 59
	
PLATE NO. : 48 IGNITION SWITCH	PAGE NO.: 61
	

Pictorial Index

PLATE NO. : 49 TOOL KIT	PAGE NO.: 62
	

PLATE NO. : 49 PAINTED PARTS & DECALS	PAGE NO.: 63 & 64
	

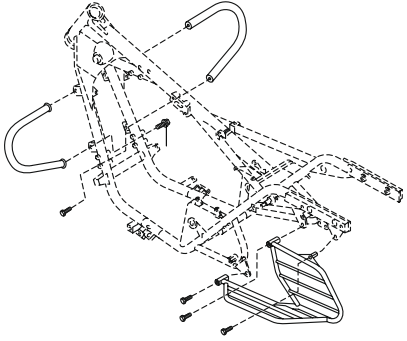
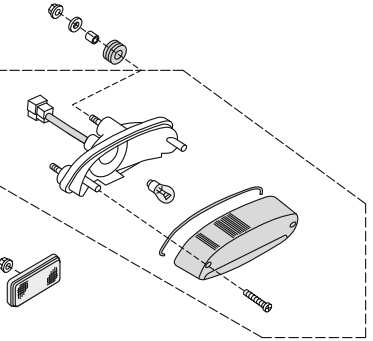
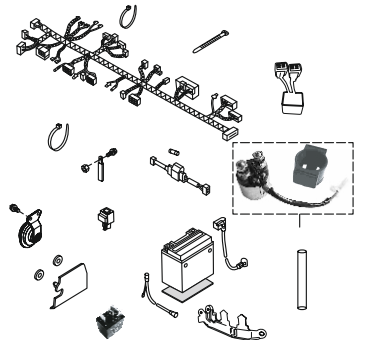
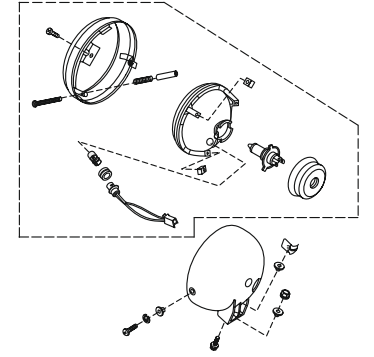
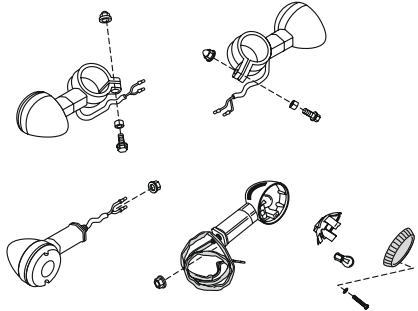
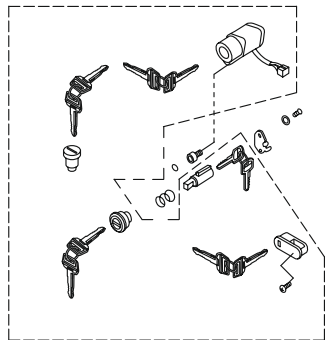

No.	Part No.	Description	Qty/ Veh.	Remarks
1	36 PD00 01	Kit Head Cylinder with Cover	1	
2	DS 1010 26	Cover Tappet	2	
3	36 DS10 01	'O' Ring Kit for Cover Cyl. Head	1	Refer Page No. 63
4	DS 1011 66	Silent Bush (V)	1	
5	DS 1010 96	Camshaft Cap	1	
6	39 2647 15	Domed Cap Nut	4	
7	DS 1010 84	Copper gasket	4	
8	59 0400 23	Hex. Bolt with Flange	2	
9	39 1075 04	Hex. Bolt with Flange M6 x 35	4	
10	DH 1012 72	Plug	2	
11	31 1011 06	Gasket	2	
	DG 1014 98	Gasket	2	ALT OF 31 1011 06

Plate No. 2 : CYLINDER HEAD

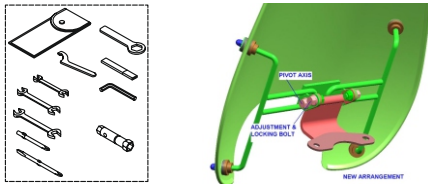
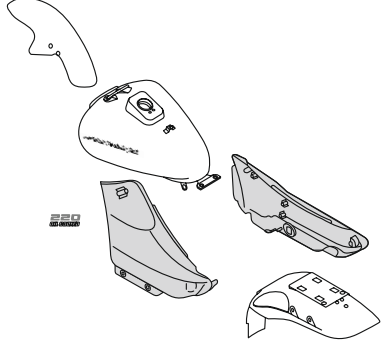
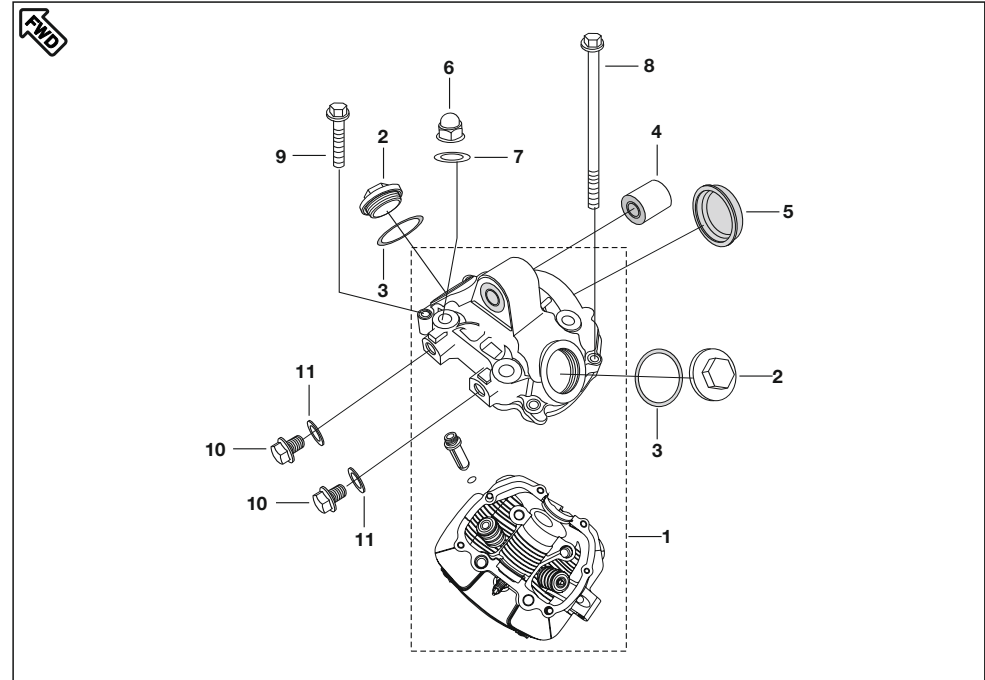
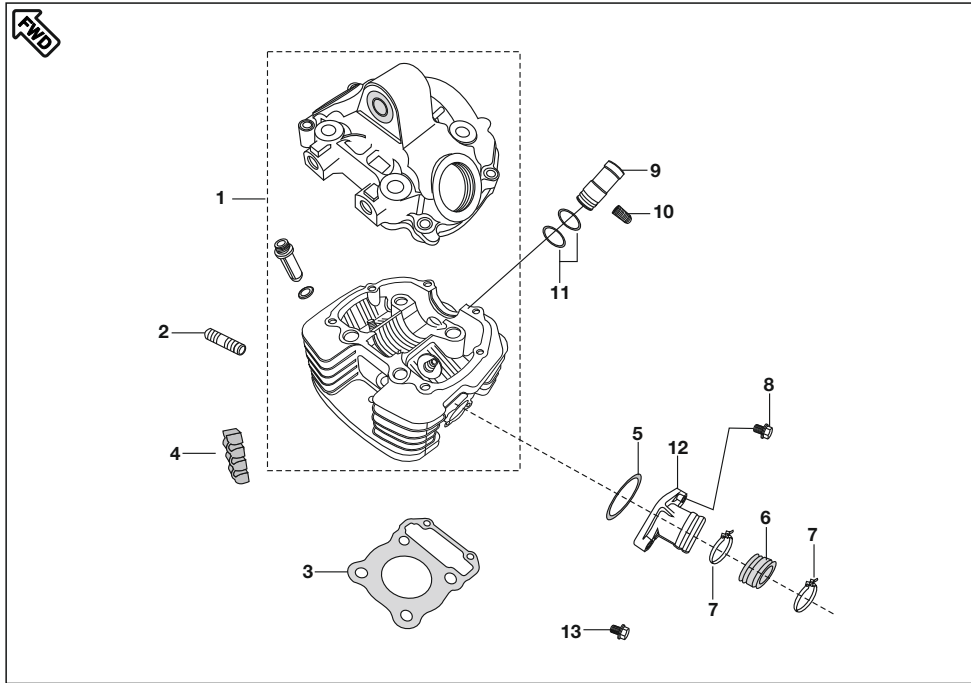

No.	Part No.	Description	Qty/ Veh.	Remarks
1	36 PD00 01	Head Cylinder with Cover	1	Part No. For Spare Part
	36 PD00 08	Head Cylinder with Cover W/o NRB	1	From Eng. no. BUF08386
2	39 1660 05	Stud (Exhaust)	2	
3	DK 1010 03	Gasket Cylinder Head	1	
4	DH 1015 08	Damper Cylinder Head	5	
5	39 1283 21	'O' Ring for Intake Pipe	1	
6	PD 5814 01	Carburetor Insulator	1	
7	DH 1210 38	Clamp for Insulator	2	
8	39 1674 04	Hex. Bolt / Flange	2	
9	DH 1110 12	Sleeve - Spark Plug	1	
10	39 2608 01	Grub Screw	1	For Sleeve Spark Plug
11	36 DS10 01	'O' Ring Kit for Cover Cyl. Head	1	Refer Page No. 63
12	PD 5090 00	Manifold	1	
13	39 1075 04	Hex. Bolt	1	N.S

Plate No. 3 : VALVE

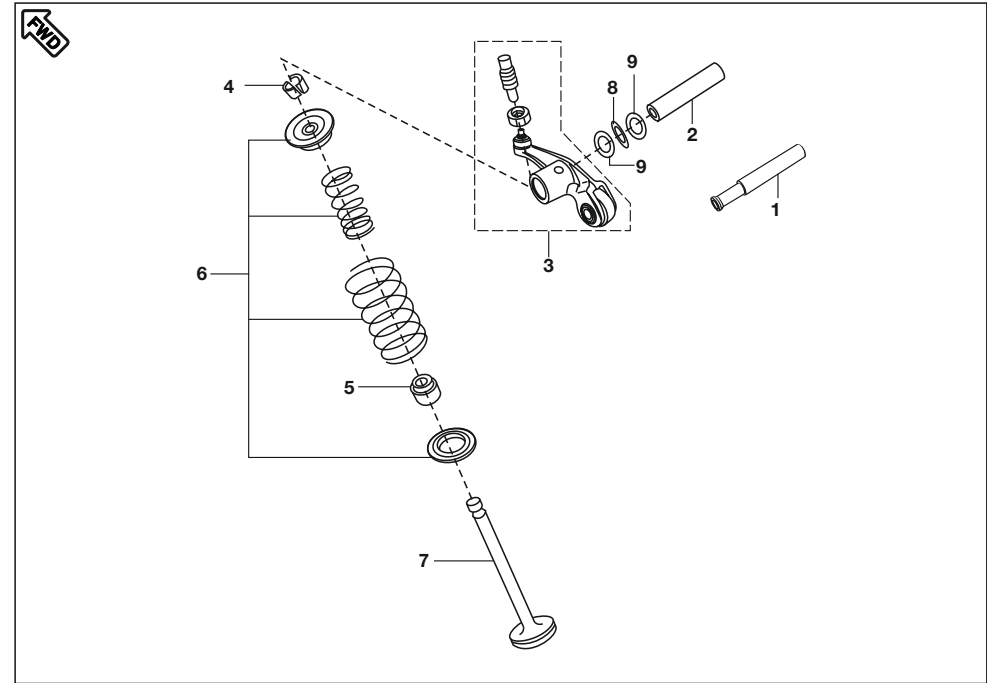

No.	Part No.	Description	Qty/ Veh.	Remarks
1	DS 1013 35	Rocker Arm Shaft - Intake	1	
	DK 1017 48	Rocker Arm Shaft - Intake	1	W/o NRB From Eng. no. BUF08386
2	DS 1013 36	Rocker Arm Shaft - Exhaust	1	
	DK 1017 51	Rocker Arm Shaft - Exhaust	1	W/o NRB From Eng. no. BUF08386
3	DS 1013 33	Rocker Arm with roller	2	
	DK 1017 55	Rocker Arm	2	W/o NRB From Eng. no. BUF08386
4	DG 1010 29	Cotter valve	4	
5	39 2017 19	Seal valve stem	2	
6	DK 1013 26	Valve Repair Kit	1	Refer Page No. 63
7	DK 1013 27	Valve Kit	1	Refer Page No. 63
8	DS 1013 66	Wave washer	2	
	DH 1012 95	Wave washer	2	From Eng. no. BUF08386
9	59 1100 02	Plain washer	4	
	39 2440 11	Plain washer	4	From Eng. no. BUF08386

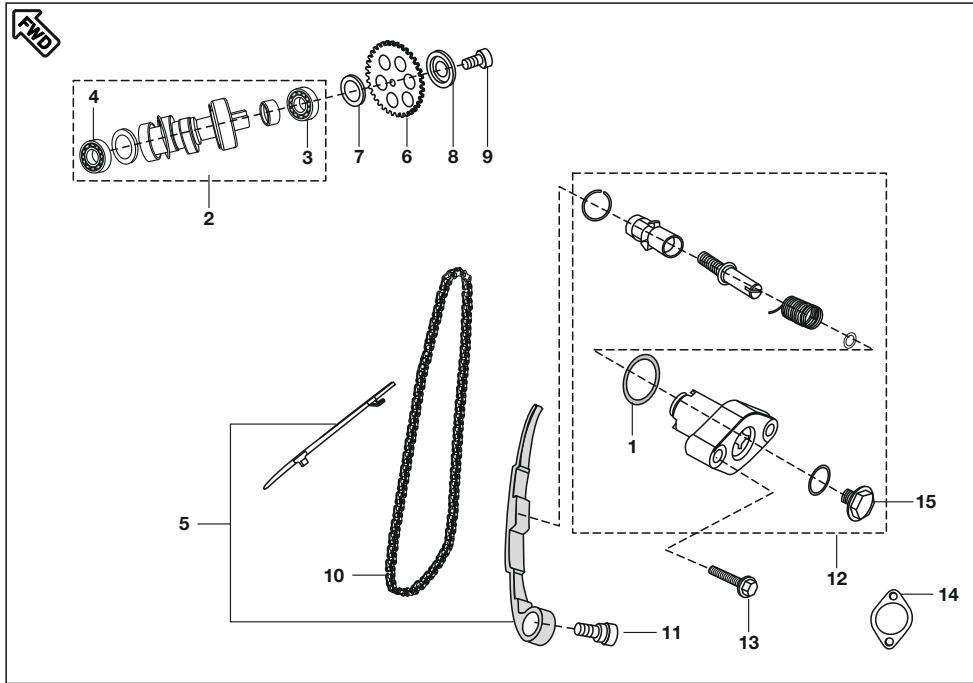

No.	Part No.	Description	Qty/ Veh.	Remarks
1	39 2669 21	Ring 'O' Tension assly	1	
2	DK 1016 14	Camshaft Assembly	1	
3	JC 1010 86	Bearing cam RH side	1	
4	JC 1010 85	Bearing cam LH side	1	
5	DK 1013 30	Guide chain Kit	1	Refer Page No. 63
6	DS 1012 76	Sprocket cam Driven (32 T)	1	
	PD 51112 29	Sprocket cam Driven	1	Ref. Cir. IB-224
7	DH 1014 12	Collar cam Sprocket	1	
8	DH 1010 48	Special camshaft washer	1	
9	DK 1013 86	Hex. Soc. Head cap Bolt	1	
10	DK 1010 64	Cam Chain	1	
11	DH 1013 92	Cam chain Tensioner pivot Bolt	1	
12	DK 1010 25	Tensioner Assly	1	
13	39 1673 04	Hex Bolt / Flange	2	
14	CS 1011 28	Tensioner assly. gasket	1	
15	DD 1010 62	Bolt	1	

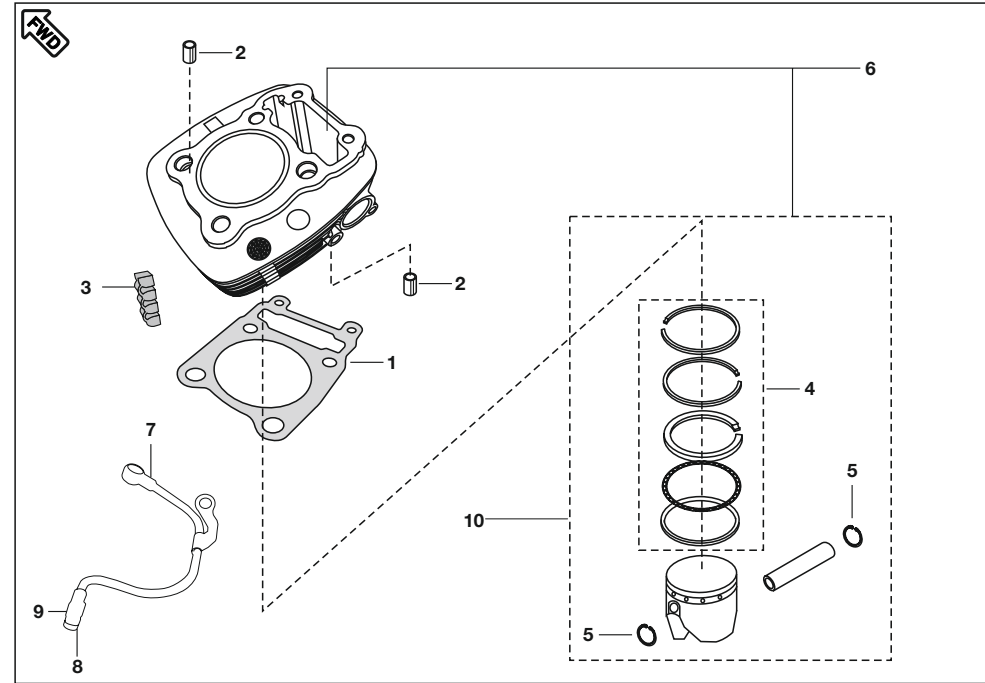

No.	Part No.	Description	Qty/ Veh.	Remarks
1	DK 1010 63	Gasket Cylinder	1	
2	39 2181 06	Pin dowel	4	
3	DH 1014 14	Damper	6	
4	DK 1013 28	Ring Set Piston	1	
5	39 2132 17	Ring Snap	2	
6	DK 1013 29	Kit Cylinder Block / Piston Assly.	1	
7	DK 1012 38	Banjo oil cooler pipe	1	
8	DD 1210 07	Bolt special	2	
9	31 1210 06	Washer copper	4	
10	DK 1010 92	Assembly Piston	1	

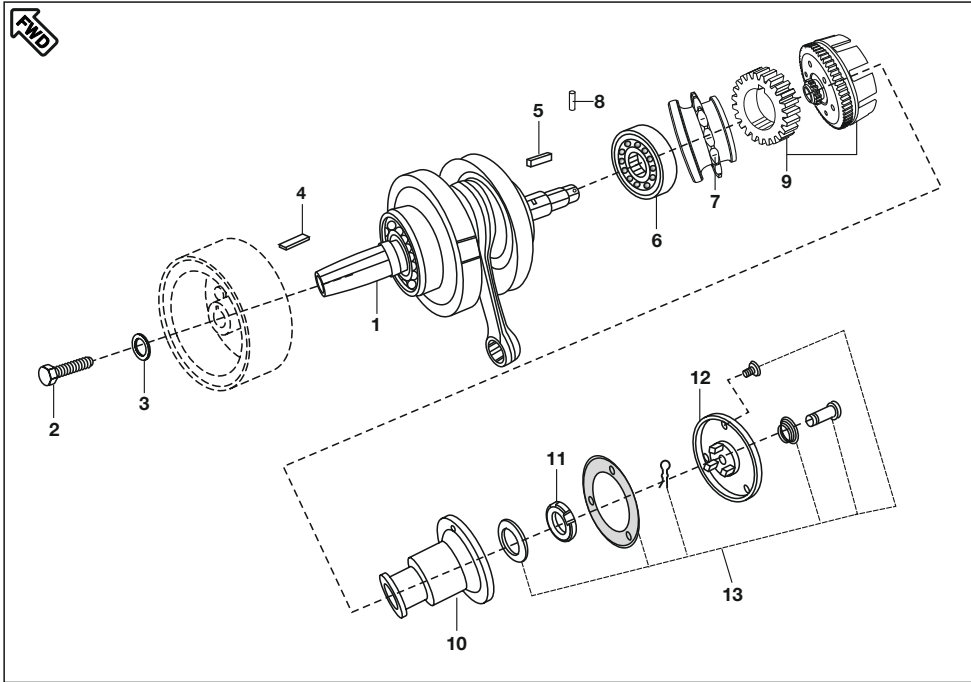

No.	Part No.	Description	Qty/ Veh.	Remarks
1	DK 1010 65	Crankshaft assly. comp.	1	
2	DH 1013 96	Bolt	1	
3	39 2165 11	Plain washer	1	
4	31 1011 73	Key woodruff	1	
5	DS 1011 54	Parallel key	1	
6	39 1931 20	Bearing Ball	1	
7	DK 1012 48	Sprocket cam drive (16 T)	1	
	PD 5310 29	Sprocket cam drive	1	Ref. Cir. IB-224
8	39 2203 07	Parallel pin	1	
9	36 DK00 38	Primary Driven Gear	1	
10	DH 1010 64	Body centrifugal oil filter	1	
11	DH 1011 95	Nut primery drive	1	
12	DH 1010 65	Cover centrifugal oil filter	1	
13	36 DK00 07	Kit centrifugal over screw oil filter	1	Refer Page No.

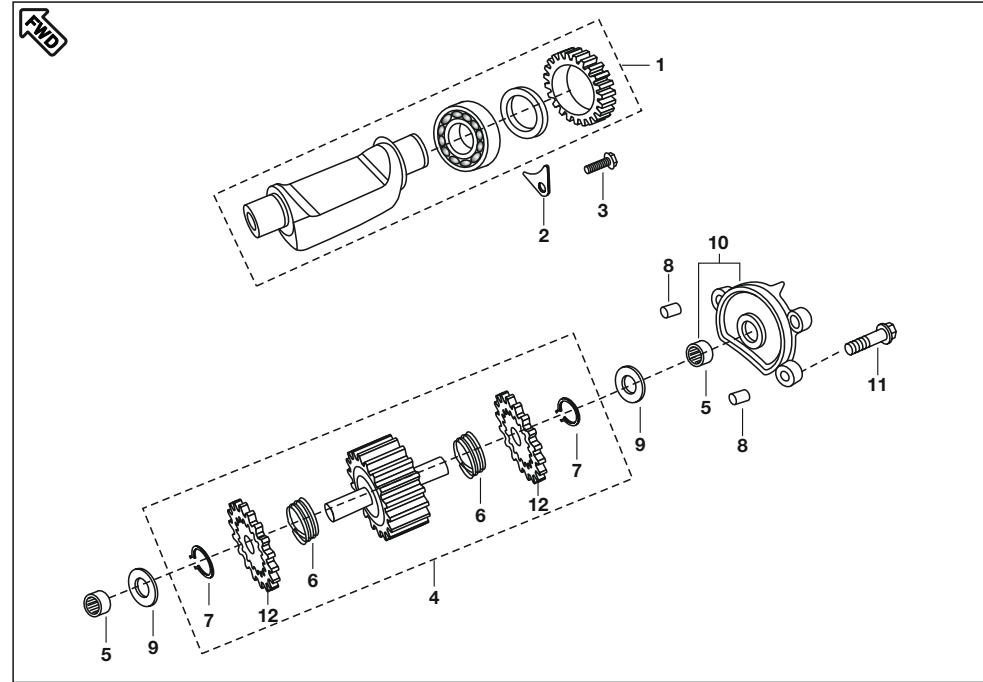

No.	Part No.	Description	Qty/ Veh.	Remarks
1	DK 1014 16	Body Balancer Assly.	1	
	DK 1017 76	Body Balancer Assly.	1	from Eng. PDZCCG10552
2	DH 1010 72	Bearing stopper	1	
3	DH 1013 85	Bolt stopper	1	
4	DH 1014 32	Assly. Balancer Idler Gear comp.	1	
	36 DH40 57	Assly. Balancer Idler Gear comp.	1	Alternate
5	39 2152 20	Needle roller bearing	2	
6	DH 1014 24	Spring torsion Balancer Idler	2	
7	39 2557 17	Circlip ext.	2	
8	39 1686 06	Dowel Pin	2	
9	39 1620 11	Spring steel washer	2	
10	52 DH01 77	Balancer Idler Holder	1	
11	39 1674 04	Hex bolt with flange	3	
12	DH 1013 73	Scissor Balancer Idler nylon	2	

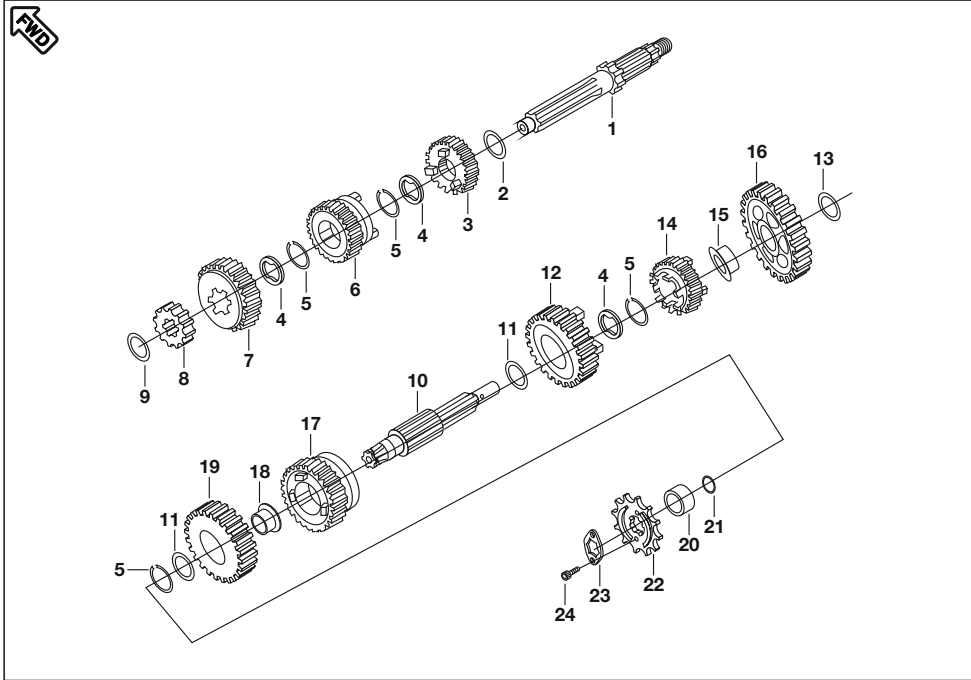

No.	Part No.	Description	Qty/ Veh.	Remarks
1	DK 1014 71	Shaft Input Transmission	1	
2	39 2158 11	Washer plain	2	
3	DK 1011 03	Gear 4th Drive	1	
4	DH 1010 79	Washer Spline	3	
5	DH 1012 35	External Circlip	4	
6	DK 1011 02	Gear 3rd Drive	1	
7	DK 1016 32	Gear 5th drive	1	
8	DH 1010 84	Gear 2nd drive	1	
9	39 2160 11	Plain washer	1	
10	DK 1011 44	Shaft output Transmission	1	
11	39 2166 11	Washer Thrust	2	
12	DK 1011 05	Gear 3rd Driven	1	
13	DH 1010 79	Washer spline	2	
14	DK 1011 06	Gear 4th Driven	1	N.S
	DK 1017 18	Gear 4th Driven	1	from Eng. no. BUC25622
15	DH 1011 11	Bush 1st driven	1	

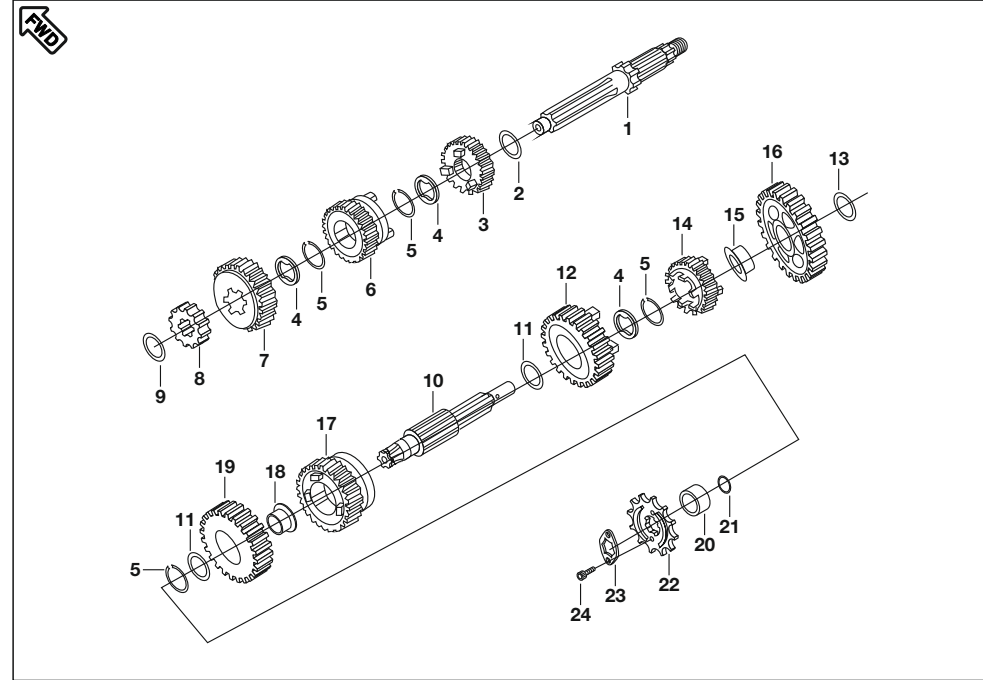

No.	Part No.	Description	Qty/ Veh.	Remarks
16	DK 1011 18	Gear 1st driven	1	N.S
	DK 1017 17	Gear 1st driven	1	from Eng. no. BUC25622
17	DK 1016 33	Gear 5th Driven	1	N.S
	DK 1017 20	Gear 5th Driven	1	from Eng. no. BUC25622
18	DH 1013 19	Bush 2nd driven	1	
19	DK 1016 60	Gear 2nd Driven	1	N.S
	DK 1017 19	Gear 2nd Driven	1	from Eng. no. BUC25622
20	DK 1012 45	Collar Sprocket	1	
21	DK 1013 52	'O' Ring Sprocket Coller	1	
22	DV 1010 48	Sprocket Drive	1	
23	DJ 1010 63	Plate Drive Sprocket	1	
24	39 1062 04	Bolt (Sprocket mtg)	2	for circlip crankcase

Plate No. 9 : CHANGE DRUM / SHIFT FORK

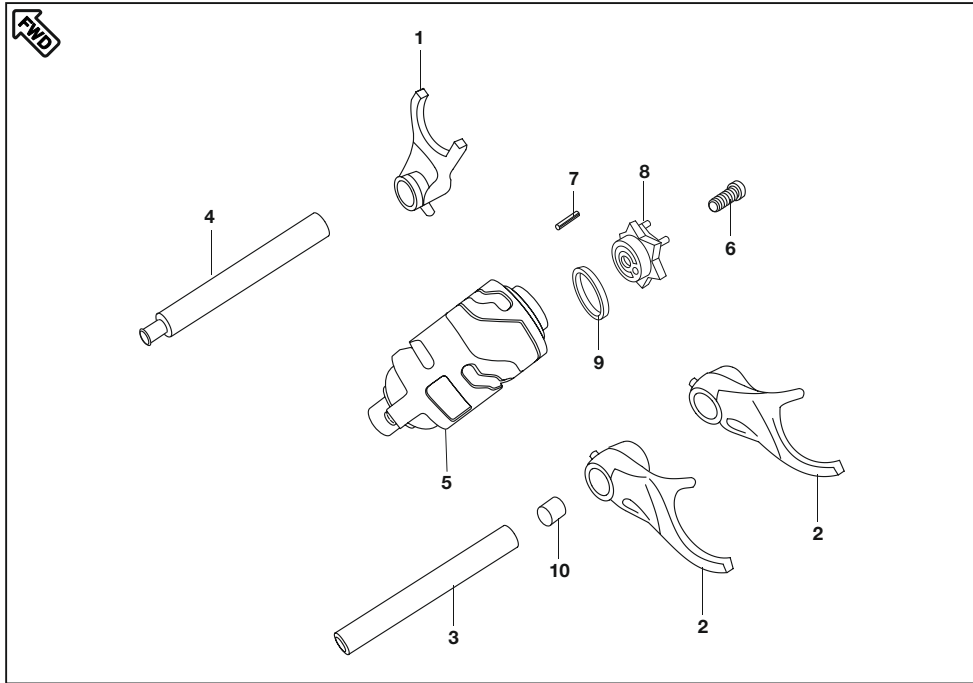

No.	Part No.	Description	Qty/ Veh.	Remarks
1	DK 1011 59	Fork Gear Shift Input	1	
2	DK 1011 60	Fork Gear Shift output	2	
3	DH 1011 46	Shaft Gear Shift Fork	1	
4	DH 1014 93	Shaft Gear Shift Fork	1	
5	DK 1013 82	Drum comp. Gear Shift	1	N.S
	DK 1017 32	Drum comp. Gear Shift	1	from Eng no. BUC25622
6	39 1197 04	Bolt Socket	1	N.S
7	39 2606 07	Parallel pin	1	
8	DK 1013 61	Guide Gear Shifter	1	
9	DH 1014 96	Spacer	1	
10	DK 1011 35	Bush Fork Gear Shift	1	

Plate No. 10 : GEAR CHANGE MECHANISM

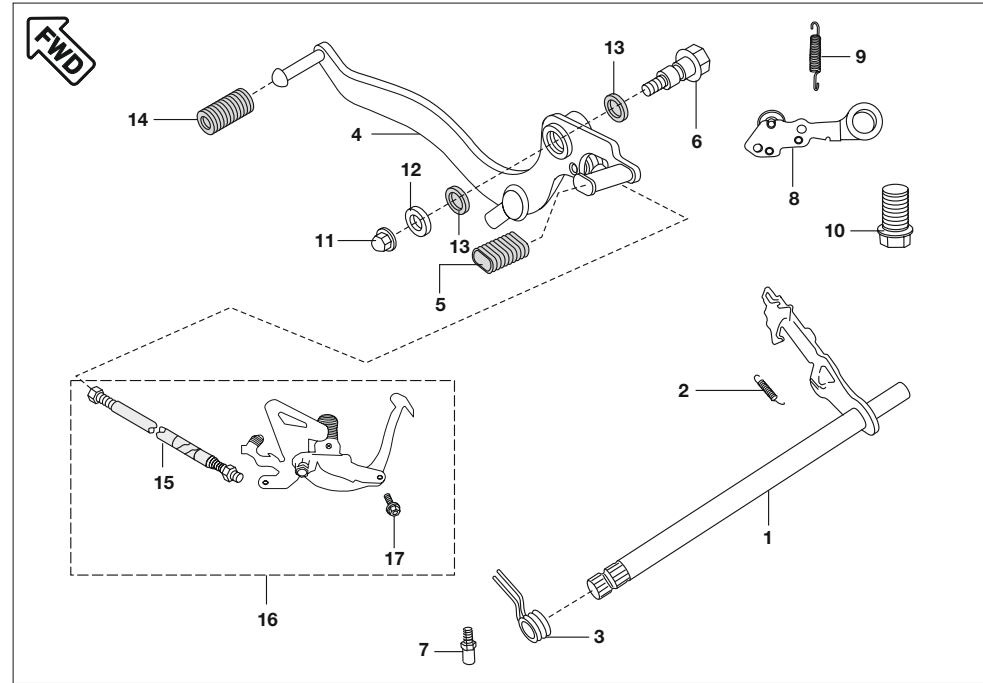

No.	Part No.	Description	Qty/ Veh.	Remarks
1	52 JM00 20	Lever comp. Gear Shifter	1	
	DK 1017 33	Lever comp. Gear Shifter	1	from Eng. no. BUC25622
2	DH 1011 43	Spring Slider arm reset	1	N.S
3	DV 1010 44	Spring Gear Shifter return	1	
4	52 DV00 52	Lever comp. change	1	
5	DG 1013 39	Damper change pedal(Rear)	1	
6	DG 1011 87	Bolt Pivot lever	1	
7	DH 1013 93	Bolt Gear Shift drum Stopper	1	
8	DH 1015 03	Stopper gear shifter drum	1	N.S
	DK 1017 25	Stopper gear shifter drum	1	from Eng. no. BUC25622
9	DV 1010 45	Spring gear shifter drum stopper	1	
10	DH 1013 94	Bolt shift change pre coated	1	
11	39 2228 15	Domed cap Nut	1	
12	39 2400 11	Washer	1	
13	39 1998 19	Oil Seal	2	
14	31 1011 08	Damper Change Pedal(Front)	1	
15	DV 1010 34	Rod assly. Tie	1	
16	52 DV00 51	Lever Assly Change	1	
17	39 2354 04	hex Bolt/ Flange	1	N.S

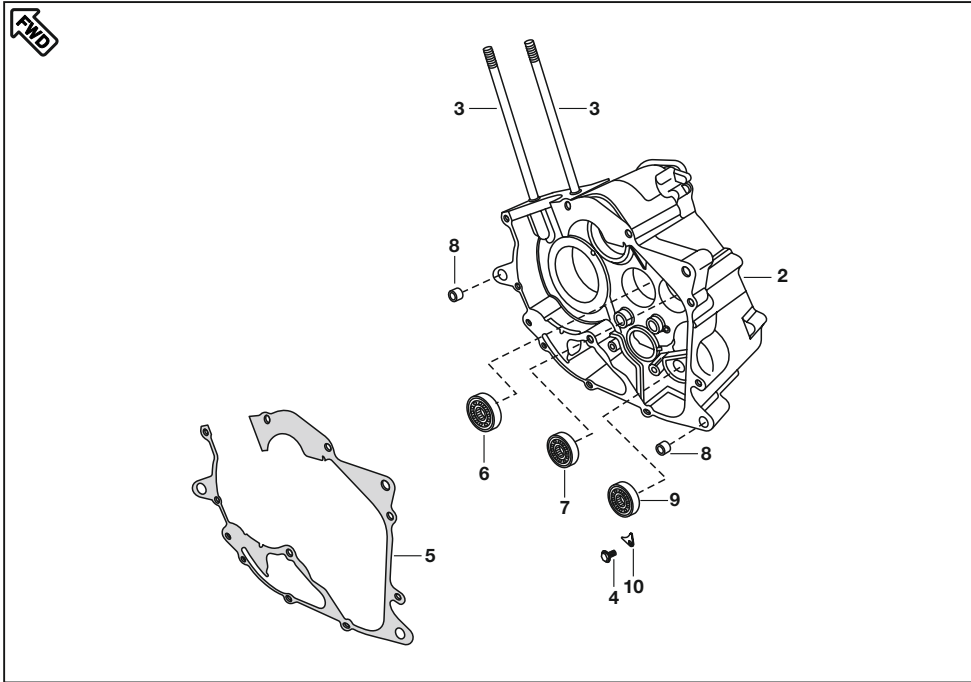

No.	Part No.	Description	Qty/ Veh.	Remarks
1	PD 5010 00	Engine Assly. with starter motor	1	N I
2	DK 1010 57	Crankcase RH	1	
3	59 0500 02	Stud	2	
4	DJ 1013 00	Bolt Flanged	1	
5	DH 1018 96	Gasket Crankcase	1	
6	39 2583 20	Bearing Ball (For Input shaft)	1	
7	39 2601 20	Bearing Ball (For Output shaft)	1	
8	39 2180 06	Dowel Pin	2	
9	59 2000 27	NRB	1	
10	DH 1014 87	Plate Stopper	1	

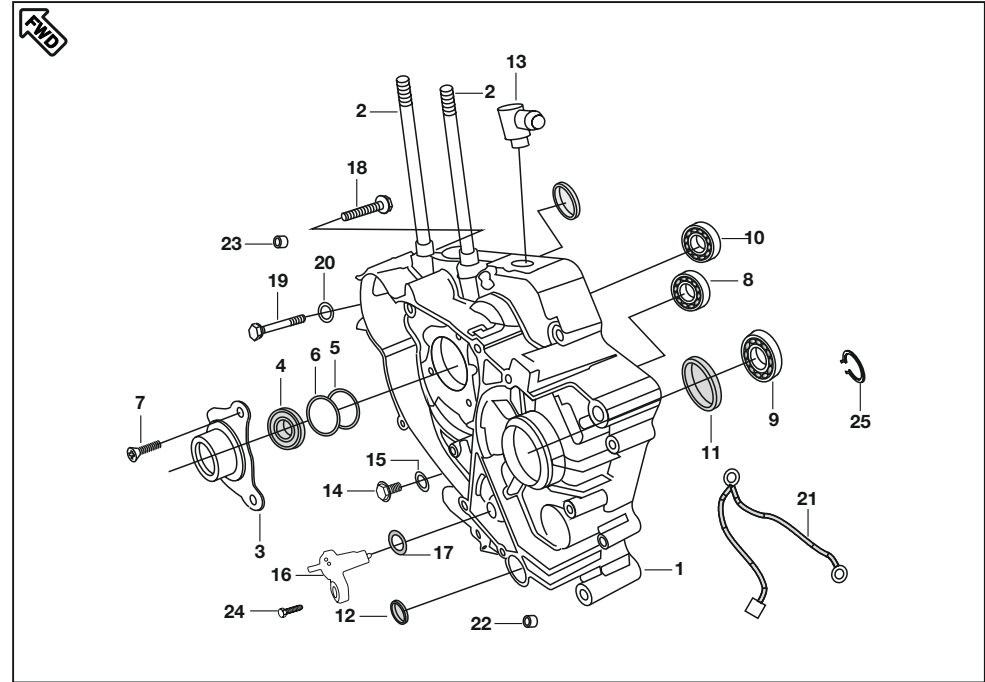

No.	Part No.	Description	Qty/ Veh.	Remarks
1	DK 1013 85	Crankcase LH	1	
2	59 0500 02	Stud	2	
3	DK 1010 94	Guide starter assly	1	
4	39 2188 19	Oil Seal	1	
5	59 2100 06	'O' Ring	1	
6	DK 1010 97	Damper	1	
7	39 0752 01	C' Sunk Head Screw	3	
8	39 2603 20	Bearing Ball (For Input shaft)	1	
9	59 2000 06	Bearing Ball (For Output shaft)	1	
10	39 2185 20	Balancer LH Bearing	1	
	59 2000 28	Balancer LH Bearing	1	from Eng. PDZCCG10552
11	39 2189 19	Oil Seal (For Output shaft)	1	
12	39 2190 19	Oil Seal (For Shift lever)	1	
13	DH 1012 03	Breather pipe fitting	1	N.S
14	DH 1016 61	Plug (Drain Bolt)	1	
15	DG 1014 98	Gasket (For Drain Bolt)	1	

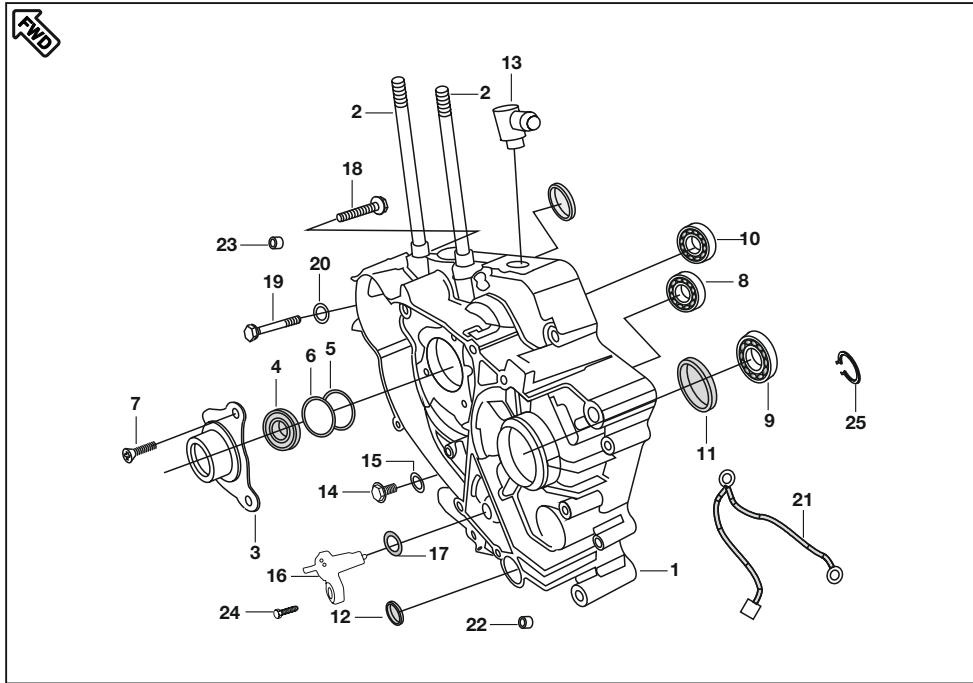

No.	Part No.	Description	Qty/ Veh.	Remarks
16	DK 1013 80	Switch comp. (Neutral)	1	N.S
17	39 1013 21	'O' ring neutral switch	1	
18	39 1677 04	Bolt	8	
19	DH 1013 90	Bolt	1	
20	DJ 2010 21	Cable assly. (Battery to Earth)	1	
21	39 2180 06	Hallow dowel pin	2	
22	39 2181 06	Hallow dowel pin	2	
23	DH 1013 85	Bolt M6X16 (Neutral Switch)	1	
24	KE BA37 15	Circlip for output shaft	1	

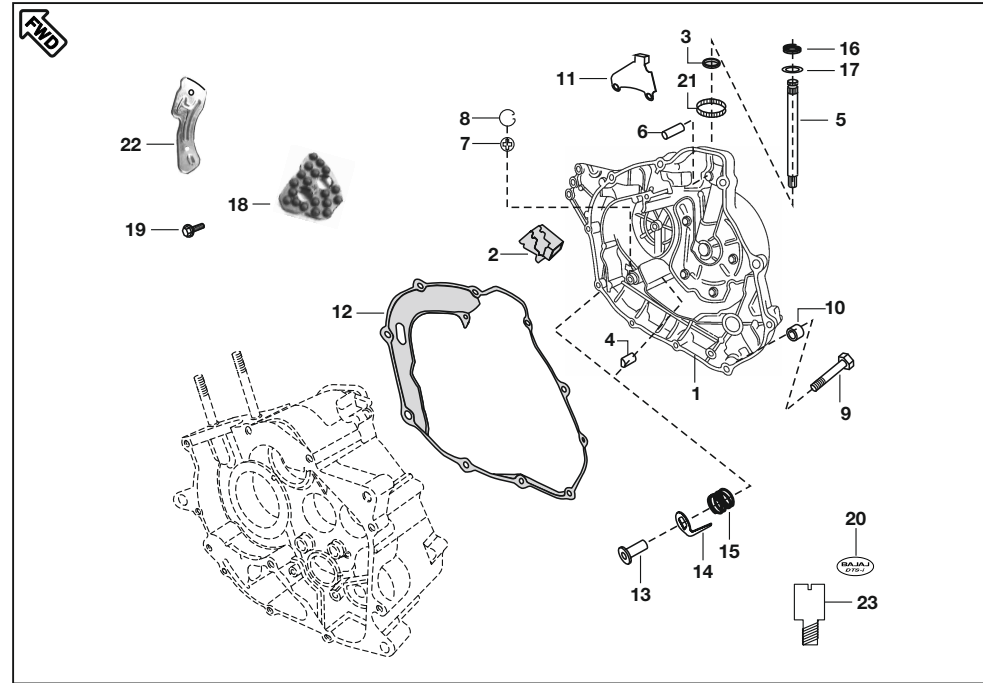

No.	Part No.	Description	Qty/ Veh.	Remarks
1	DK 1010 76	Cover comp RH With Relief Valve	1	from Eng. no. BTH09115
	36 PD00 06	Cover comp RH Flower Type	1	
2	DH 1011 97	Grommet Breather	1	
3	39 1041 19	Oil Seal	1	
4	DH 1011 41	Rack	1	
5	DH 1011 42	Shaft clutch release	1	
6	DK 1012 51	Parallel pin	1	
7	DG 1014 18	Gauge	1	
8	DS 1012 15	Wire circlip	1	
9	DS 1013 53	Bolt	10	
10	39 0999 06	Pin Dowel	2	
11	DK 1012 52	Bracket Clutch Cable	1	
12	DH 1011 54	Gasket cover RH	1	
13	DK 1014 80	Plunger Oil	1	
14	DH 1210 11	Plate Plunger Oil	1	
15	DH 1210 12	Spring Joint 'A'	1	
16	DK 1017 38	Decal Clutch Cover	1	N.I. from Eng. no. BTH09115

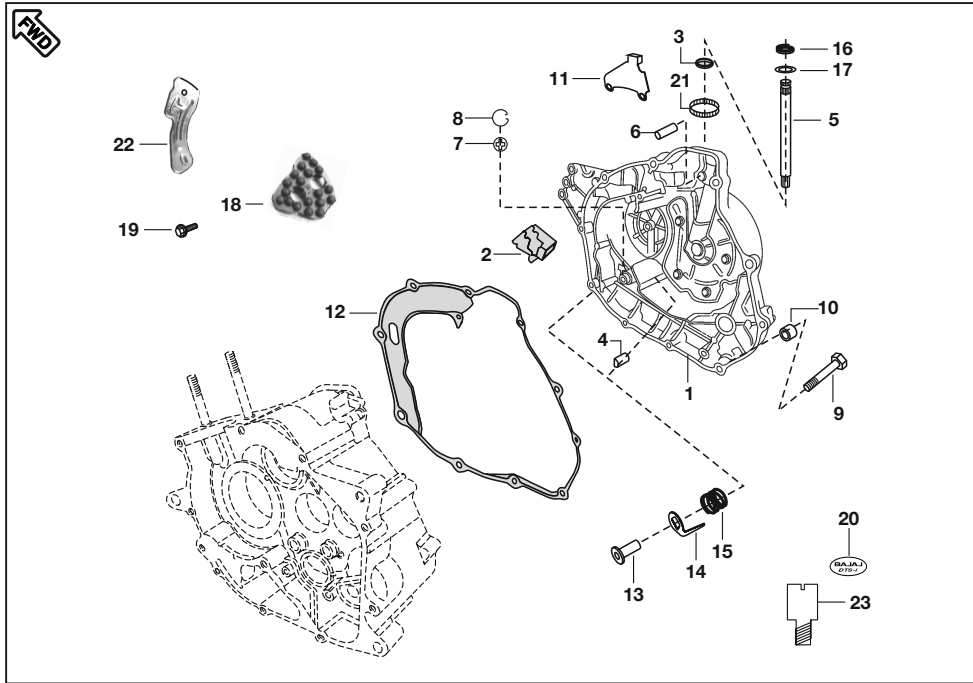

No.	Part No.	Description	Qty/ Veh.	Remarks
16	DH 1015 44	Spring torsion clutch lever	1	
17	39 2443 11	Washer	1	
18	DH 1015 10	Damper	1	N.S
19	DH 1013 88	Flanged Bolt	8	
20	JC 1010 40	'Bajaj' Decal	1	Fitted on Cover comp. RH
21	39 1990 20	NRB	2	
22	DH 1014 82	Plate	1	N.S
23	DK 1014 69	Pressure relief valve assly.	1	

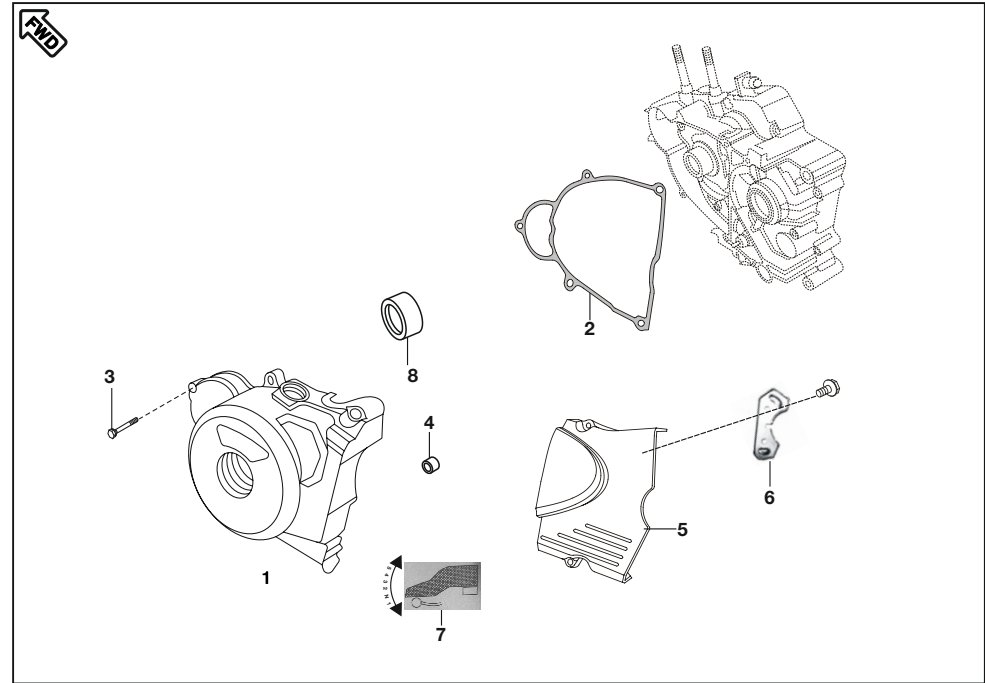

No.	Part No.	Description	Qty/ Veh.	Remarks
1	DK 1010 84	Cover Magneto	1	N.S
	52 PD00 13	Cover Magneto Flower Type	1	from Eng. no. BTH09115
2	DV 1010 42	Gasket Magneto cover	1	
3	DH 1013 96	Bolt	7	
4	39 0999 06	Pin Dowel	2	
5	52 JM00 13	Cover LH RR	1	
6	DH 1012 93	Plate Damper Cover LH Rear	1	
7	DJ 1610 12	Gear Shift Label	1	
8	39 2240 20	NR bearing	1	N.S
9	JE 5412 12	Decal Magneto Cover	1	N.I. from Eng. no. BTH09115

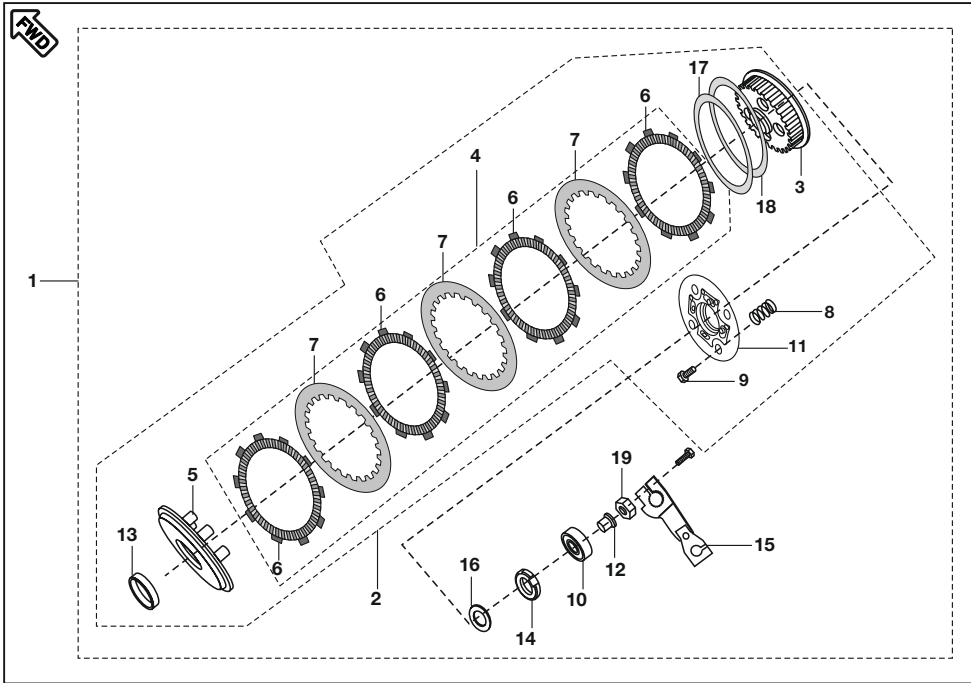

No.	Part No.	Description	Qty/ Veh.	Remarks
1	DK 1015 60	Clutch assembly comp.	1	
2	DK 1015 63	Clutch Plate Assly	1	
3	DK 1015 64	Clutch Center	1	
4	DK 1013 56	Friction clutch plate kit	1	
5	DK 1015 69	Plate Clutch pressure	1	
6	DJ 1013 69	Friction Plate Kit	1	
7	DK 1015 65	Plate Clutch	4	
8	DK 1015 72	Spring Clutch Capacity	6	
9	DK 1015 74	Bolt	6	
10	39 1880 20	Bearing Clutch lifter thrust	1	
11	DK 1015 73	Holder Clutch	1	
12	DK 1010 72	Rod Clutch lifter	1	
13	DK 1011 26	Spacer Clutch	1	
14	DH 1016 48	Nut Primary drive lock	1	LH Thread
15	DK 1016 36	Lever Assly. Clutch	1	

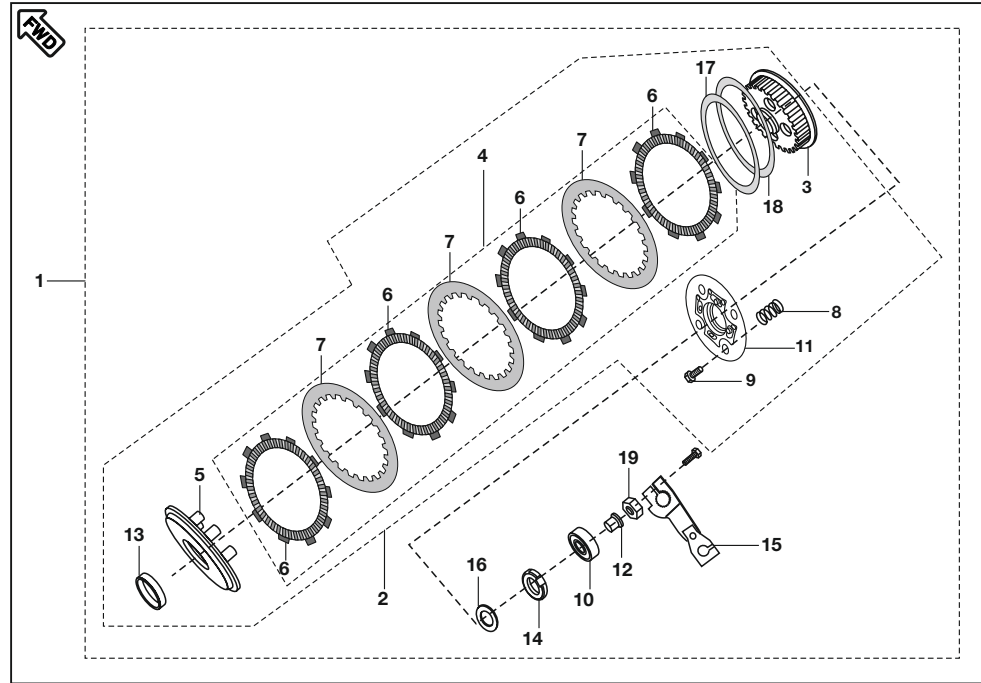

No.	Part No.	Description	Qty/ Veh.	Remarks
16	39 2200 11	Washer Primary Drive Gear	1	
17	DK 1015 70	Seat Judder Spring	1	
18	DK 1015 71	Spring Judder	1	
19	DH 1012 75	Special Nut	1	

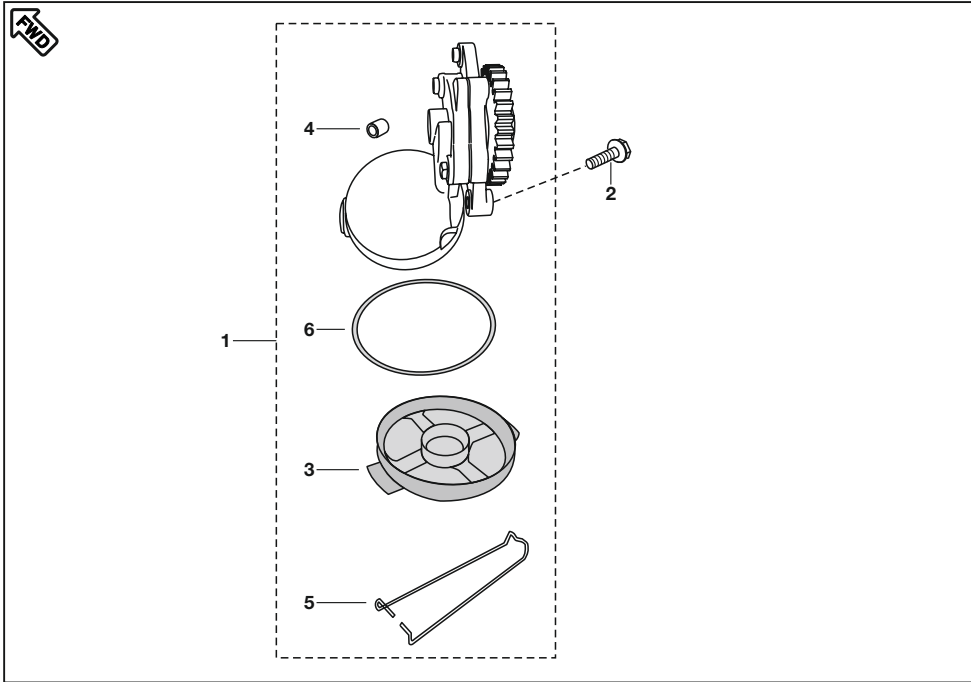

No.	Part No.	Description	Qty/ Veh.	Remarks
1	52 DH01 69	Oil Pump Assly	1	
2	39 1674 04	Hex. Bolt with flange	3	
3	DH 1210 10	Mesh filter Oil pump	1	
4	39 1686 06	Hollow dowel pin	1	
5	DH 1210 35	Clip Mesh Oil filter	1	
6	39 2194 21	'O' Ring	1	

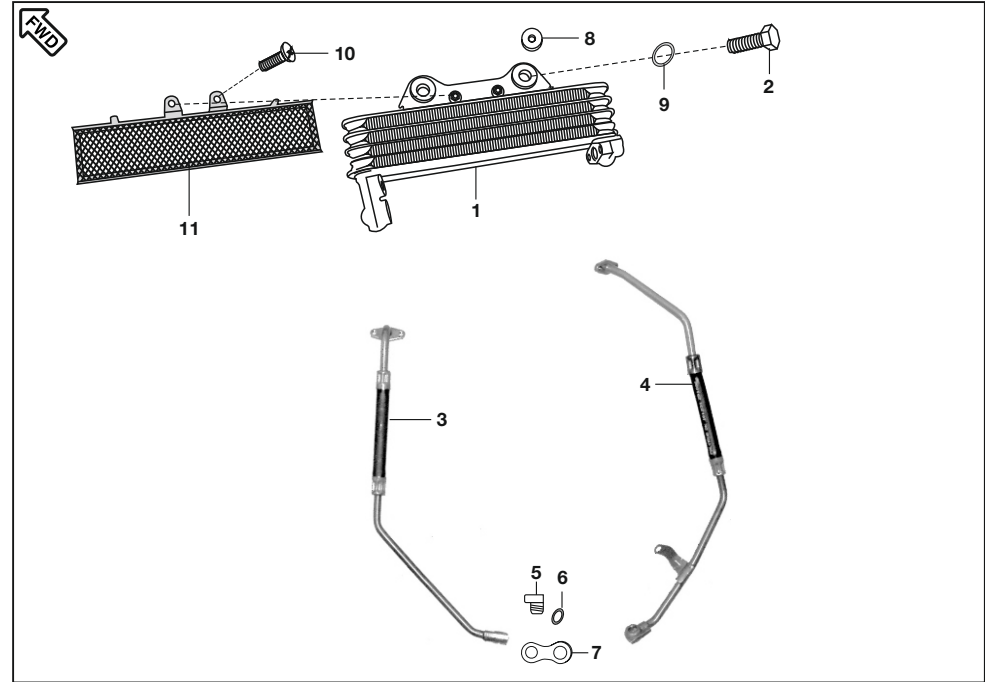

No.	Part No.	Description	Qty/ Veh.	Remarks
1	PD 5712 00	Oil cooler assembly	1	
2	DH 1013 85	Bolt	1	
3	PD 5712 01	Pipe inlet oil cooler	1	
4	PD 5712 03	Pipe outlet oil cooler	1	
5	DK 1013 66	Banjo bolt	2	
6	DK 1012 37	Gasket Banjo bolt	4	
7	DK 1012 79	Washer Oil Cooler	1	
8	DK 1610 81	Rubber	2	
9	DK 1013 40	'O' ring oval	1	
10	39 2637 04	Hexagon Head Screw	2	
11	DK 1016 35	Oil cooler jali	1	

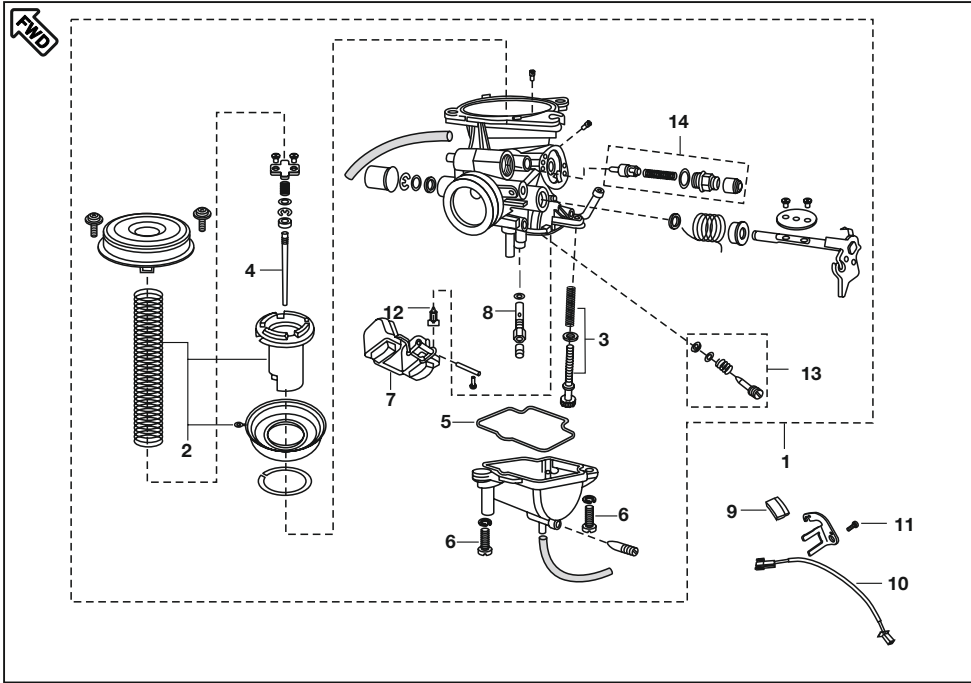

No.	Part No.	Description	Qty/ Veh.	Remarks
1	PD 5812 00	Carburettor Assly.	1	
2	PD 5812 02	Vacuum Piston Kit	1	
3	PD 5812 03	Idling Screw Kit	1	
4	PD 5812 05	Jet needle(JN)	1	
5	PD 5812 04	Float bowl "O" ring	1	
6	PD 5812 06	Float bowl Screw	2	
7	PD 5812 07	Float Assly.	1	
8	PD 5812 08	Jet Holder	1	N.S
9	DH 1211 01	Magnet Assly.	1	
10	DJ 1210 70	Reed Switch Assly.	1	
11	39 1780 01	Pan Head Screw	2	
12	PD 5812 11	Needle Assly.	1	
13	PD 5812 12	Set Adjuster (PS)	1	
14	DJ 1210 59	Set Plunger Assly.	1	
15	JM 1200 05	Air jet (Fixed in body)	1	N.I.
16	DD 1110 46	TPS Assly	1	

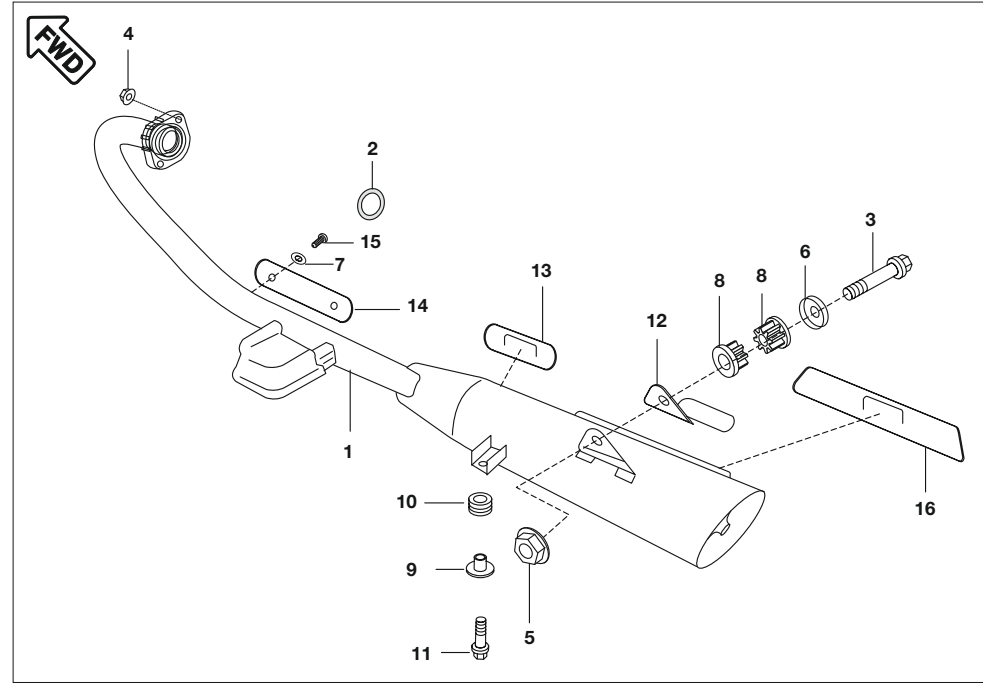

No.	Part No.	Description	Qty/ Veh.	Remarks
1	PD 5910 05	Silencer Assly. without cover (With CAT & Resonator)	1	
2	DG 1014 17	Gasket Exhaust pipe holder	1	
3	DG 1012 85	Bolt	1	
4	39 2228 15	Domed cap Nut	2	
5	39 1225 15	Nut flanged	1	
6	DG 1012 49	Washer	1	N.S
7	PD 5911 00	Washer	4	**From Chassis. MD2A22EZ9CCE06487
8	DG 1014 19	Bushing rubber, muffer	2	
9	DG 1014 10	Collar	1	N.S
10	DG 1012 53	Damper	1	N.S
11	39 2209 04	Bolt Flanged	1	
12	DG 2210 38	Gaurd Muffer	1	
13	DV 1010 57	Cover Muffer	1	
14	DV 1010 35	Shield Exhaust tube	1	
15	DH 1016 07	Truss Screw	6	
	PD 5911 01	Truss Screw	6	**From Chassis. MD2A22EZ9CCE06487
16	DV 1010 56	Cover Muffer	1	

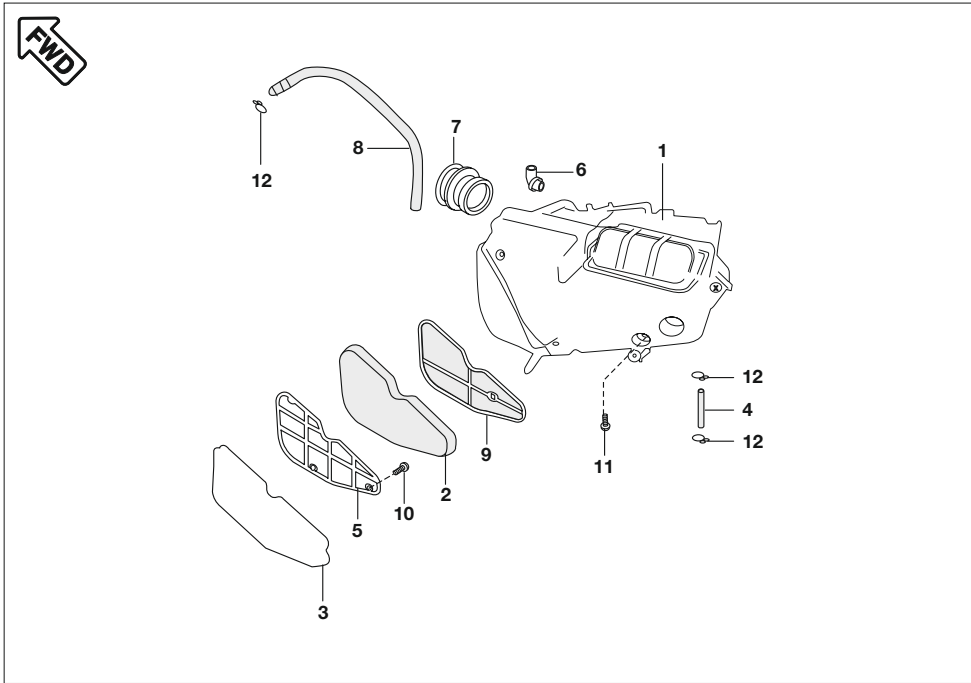

No.	Part No.	Description	Qty/ Veh.	Remarks
1	PD 5810 00	Air Filter Assly.	1	
2	DG 1210 10	Element Air filter	1	
3	DG 1210 12	Gasket Air filter	1	N.S
4	DG 1210 20	Tube	1	N.S
5	DG 1210 14	Plate Element	1	N.S
6	52 DV00 32	Tube Breather	1	
7	PD 5090 01	Connecting tube	1	
8	DV 1210 05	Tube Rubber	1	
9	DG 1210 23	Flame Arrester	1	
10	39 2044 01	Screw	5	
11	39 0747 01	Screw	5	
12	DG 1210 26	Clamp	2	N.S

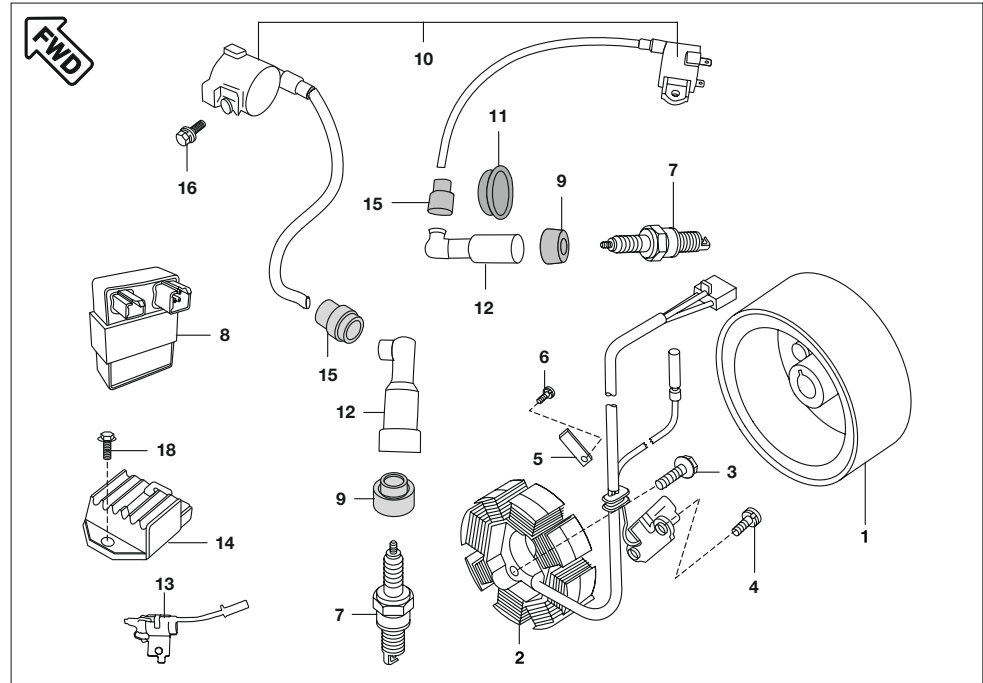

No.	Part No.	Description	Qty/ Veh.	Remarks
1	JC 1110 28	Rotor	1	
2	JC 1110 26	Stator Assly. comp	1	
3	39 1674 04	Hex. Bolt with Flange	2	
4	39 0761 01	Pan Head Screw	2	
5	DH 1011 99	Stopper plate (wiring harness)	1	
6	39 0746 01	Screw Pan head	1	
7	DK 1110 28	Spark plug	2	
8	PD 3512 00	C.D.I Assly. / Damper	1	
9	DH 1110 13	Grommet Spark Plug cap	2	
10	PD 3512 05	H.T. Coil Kit	1	Refer Page No. 63
11	DH 1110 16	Grommet Sleeve Spark Plug	1	
12	DH 1110 15	Cap Spark Plug	2	
13	PD 4020 02	Capacitor with bracket	1	
14	PD 4020 03	Regulator Voltage	1	
15	DD 1110 12	Grommet H.T. Cable	2	

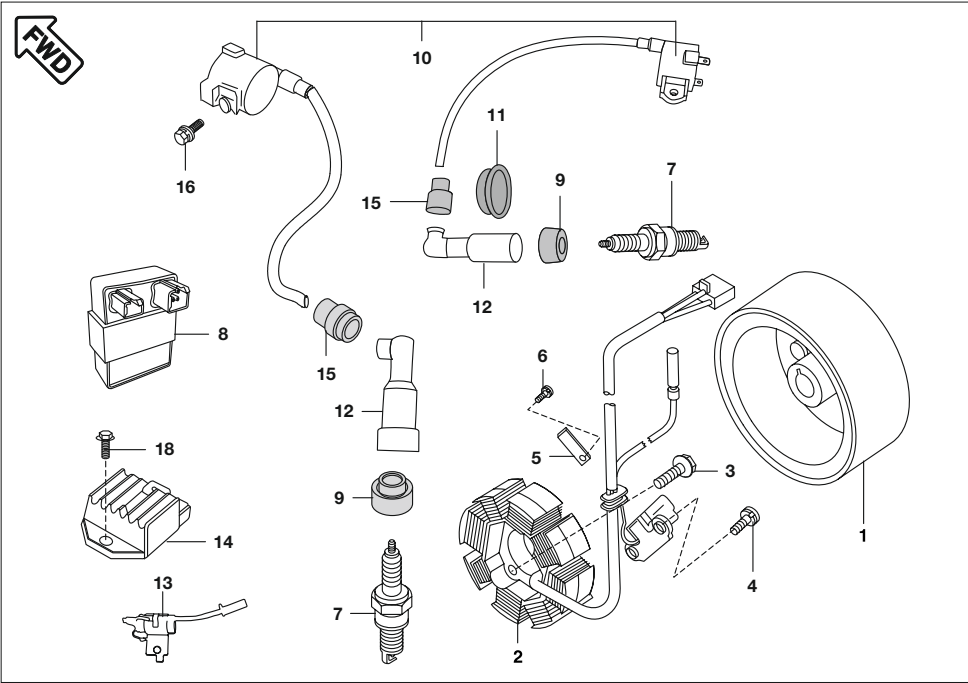

No.	Part No.	Description	Qty/ Veh.	Remarks
16	39 1902 04	Flange Bolt	2	N.I.
17	59 1000 02	Spring dowel	1	
18	39 1950 04	Flange Bolt small (regulator)	2	

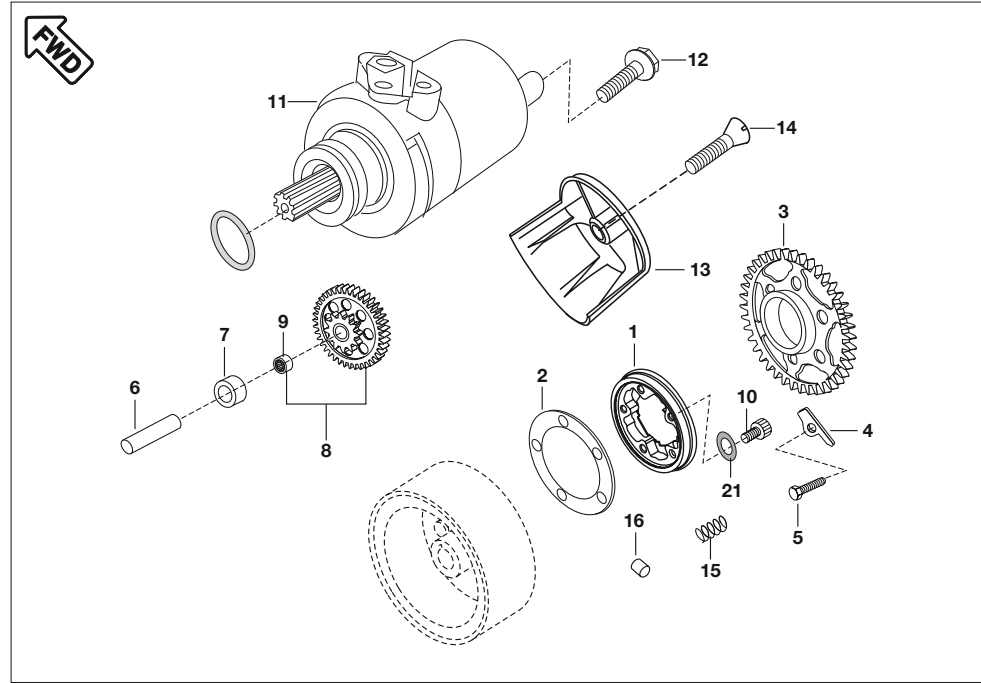

No.	Part No.	Description	Qty/ Veh.	Remarks
1	36 DK00 76	Kit comp. starter clutch	1	Ref. Cir. D-40
2	DK 1016 05	Plate roller clutch	1	
3	JC 1011 14	Gear starter clutch	1	
4	DH 1015 81	Plate starter clutch gear return	1	Stopper plate
5	DH 1013 85	Bolt	1	For stopper plate
6	DK 1011 76	Shaft starter counter	1	
7	DH 1011 72	Collar starter counter	1	
8	JC 1011 15	Gear comp. starter counter assly.	1	
9	59 2000 07	Needle roller bearing	1	
10	39 0972 04	Bolt socket	3	
11	DK 1110 09	Starter Motor	1	
12	39 1074 04	Bolt	2	
13	DH 1011 84	Cover starter motor	1	
14	39 2285 01	Slotted c'sunk screw	1	
15	36 DK00 77	Kit Spring Starter Clutch	1	Ref. Cir. D-40
16	DH 1011 63	Roller	5	
18	DK 1015 96	Spring comp st. clutch	1	
20	36 DK00 45	Molicoat grease	1	N.S
21	39 0849 14	Star Washer	3	

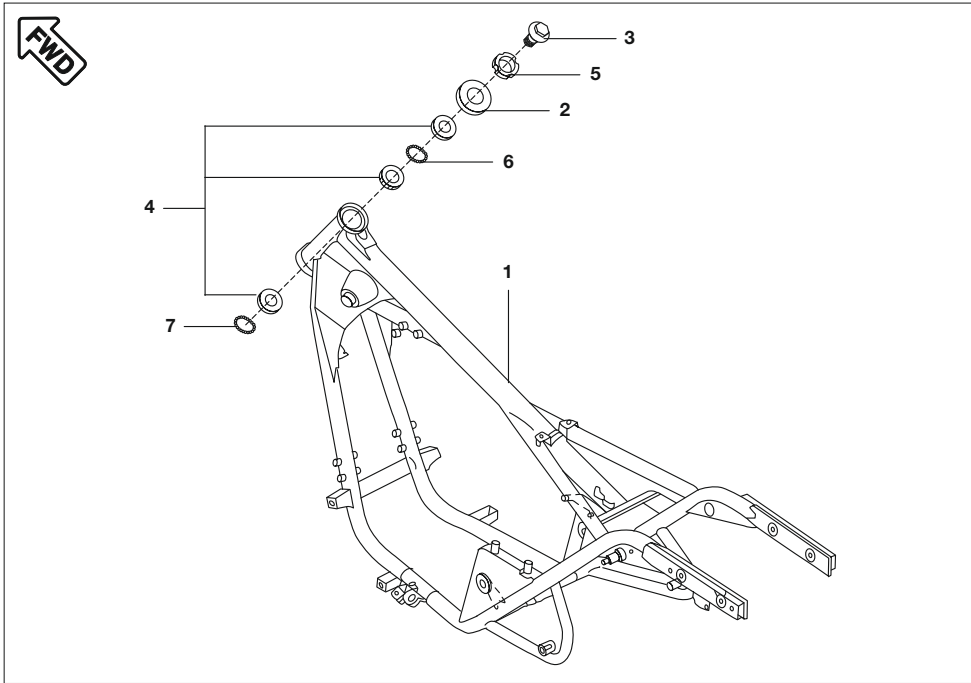

No.	Part No.	Description	Qty/ Veh.	Remarks
1	PD 1110 01 PD 1110 09	Frame comp. Frame comp. (Ign. switch Position Change)	1 1	from Chs. no. TCL16332
2	DG 1810 42	Cap Steering Stem	1	
3	59 0400 05	Bolt flanged	1	
4	36 DV00 07	Steering Cone Kit	1	Refer Page No. 63
5	DG 1810 48	Nut	1	
6	DK 1810 50	Cage bearing upper	1	
7	DK 1810 51	Cage bearing lower	1	

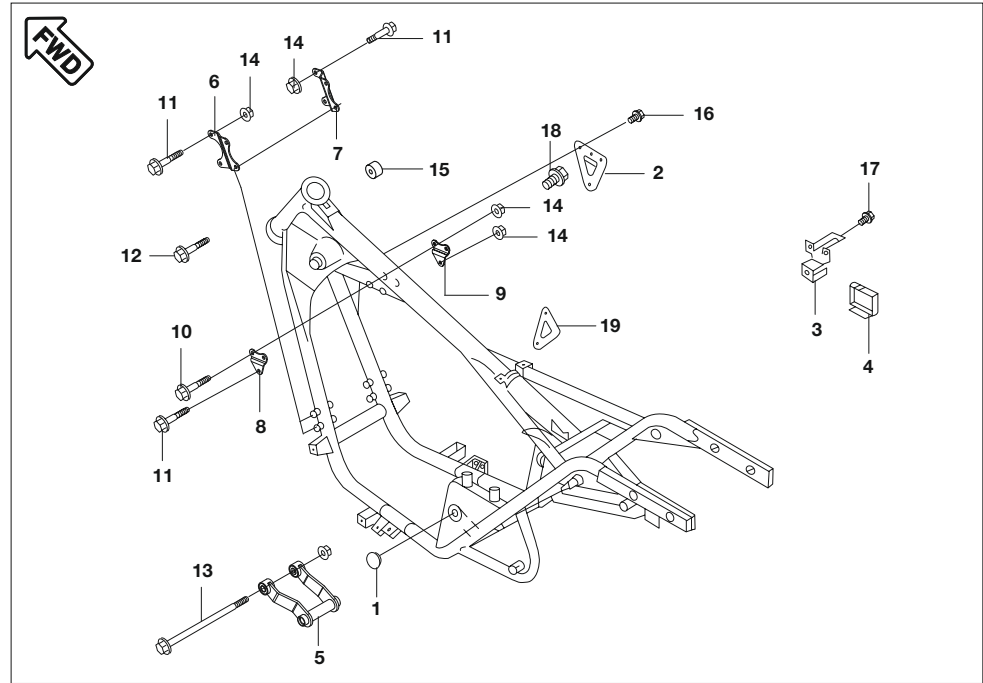

No.	Part No.	Description	Qty/ Veh.	Remarks
1	DG 1611 54	Cap, Pivot	2	
2	DG 1611 63	Bracket, Igniter	1	N.S
3	DG 1612 08	Engine Bracket	1	N.S
4	DG 1611 65	Cap, Tool case	1	
5	JM 1610 04	Bracket, Engine Rear	1	
6	JM 1610 02	Bracket, Engine Mtg. Front LH	1	
7	JM 1610 03	Bracket, Engine Mtg. Front RH	1	
8	PD 1134 00	Bracket, Engine Top LH	1	
9	PD 1134 01	Bracket, Engine Top RH	1	
10	39 2681 04	Bolt	4	N.S
11	39 1966 04	Bolt, Flanged	1	N.S
12	39 2157 04	Bolt	3	
13	59 0400 43	Bolt, Allen	1	
14	39 0291 15	Nut Flanged	11	
15	DG 1612 24	Damper	1	

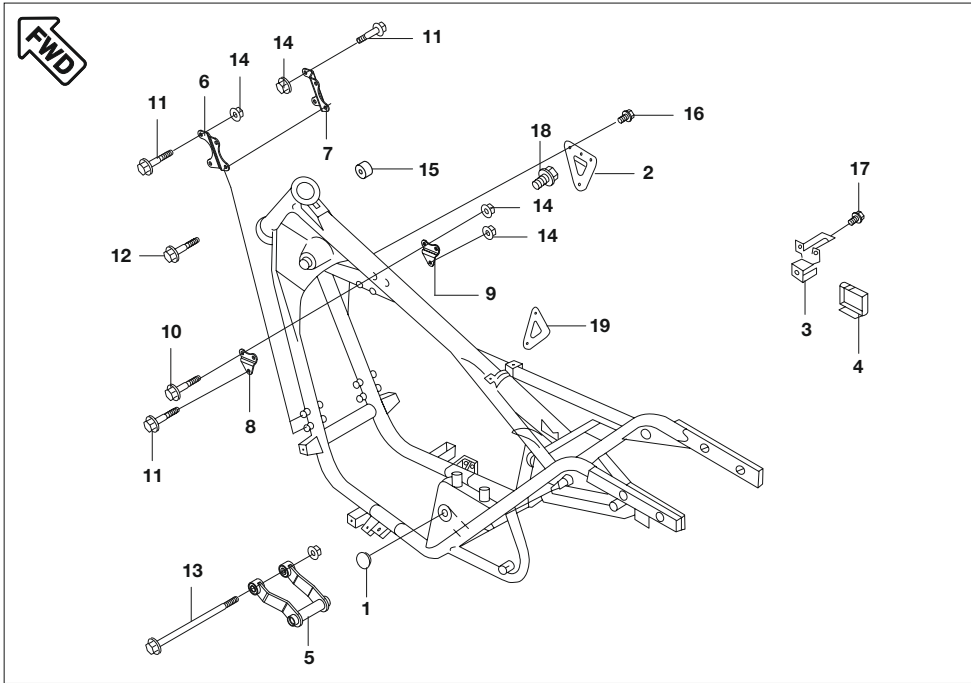

No.	Part No.	Description	Qty/ Veh.	Remarks
16	39 1912 04	Bolt Flanged	2	
17	39 1944 04	Bolt Flanged	2	
18	39 2455 04	Bolt	3	N.S
19	DG 1612 08	Bracket Engine	1	N.S
20	JC 2010 36	Side Reflex Reflector	2	For Argentina

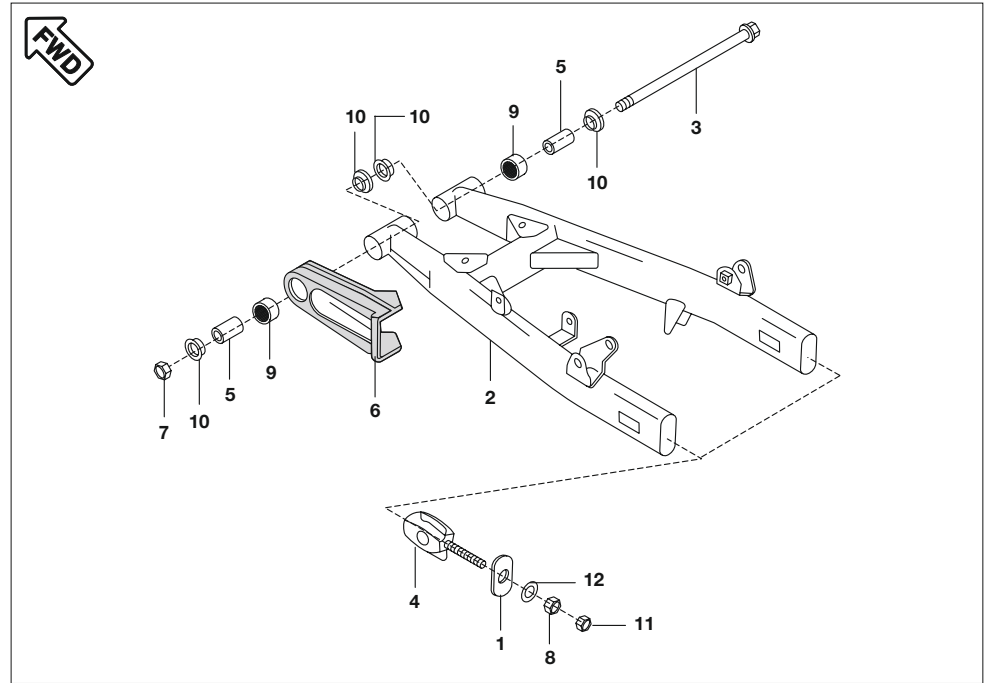

No.	Part No.	Description	Qty/ Veh.	Remarks
1	JM 1710 04	Cap chain Adjuster	2	
2	PD 1220 00	Arm Comp. Swing	1	
3	DG 1710 15	Shaft Swing Arm	1	
4	JM 1710 03	Adjuster Chain	2	
5	DG 1710 16	Sleeve	2	
6	DG 1710 34	Guard, Chain	1	
7	DG 1710 17	Nut	1	N.S
	39 1053 15	Nut	1	alt for DG 1710 17
8	DG 1710 22	Nut	2	
9	DG 1710 18	Bearing Needle	2	
10	DG 1710 19	Seal Oil	4	
11	39 1997 15	Nut Hex small	2	
12	39 1224 11	Washer Plain small	2	

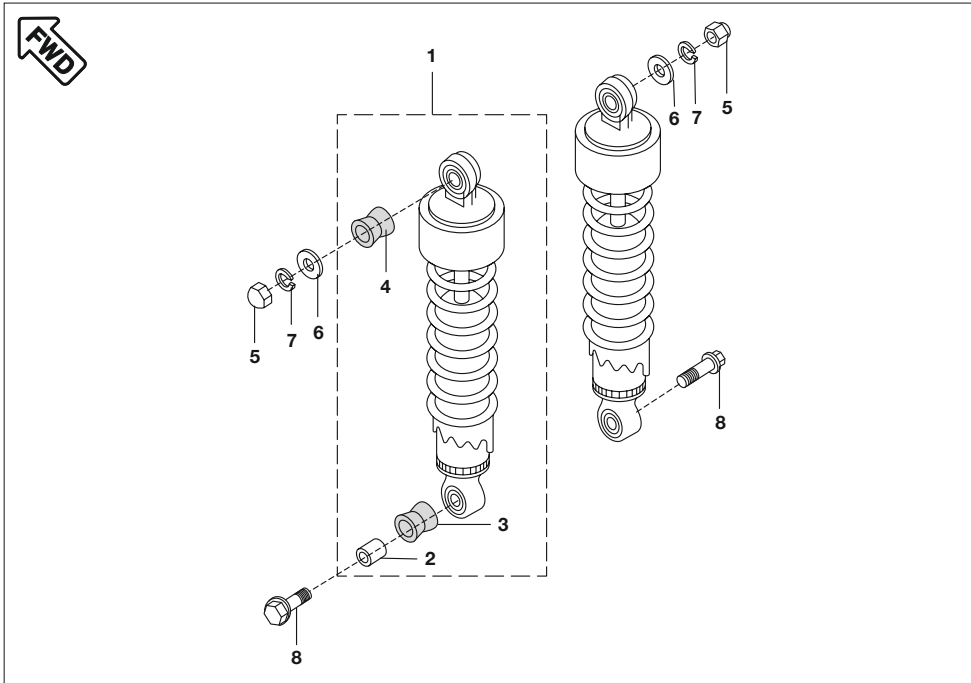

No.	Part No.	Description	Qty/ Veh.	Remarks
1	DV 1710 01	Rear Shock Absorber	2	N.S
2	DG 1710 35	Collar, shock Absorber	2	
3	DG 1710 37	Damper, Lower	2	
4	DG 1710 36	Damper, Upper	2	
5	DG 1710 39	Nut cap	2	
6	DG 1710 25	Washer	2	
7	39 1829 12	Spring Washer	2	
8	DG 1710 38	Bolt Flanged	2	

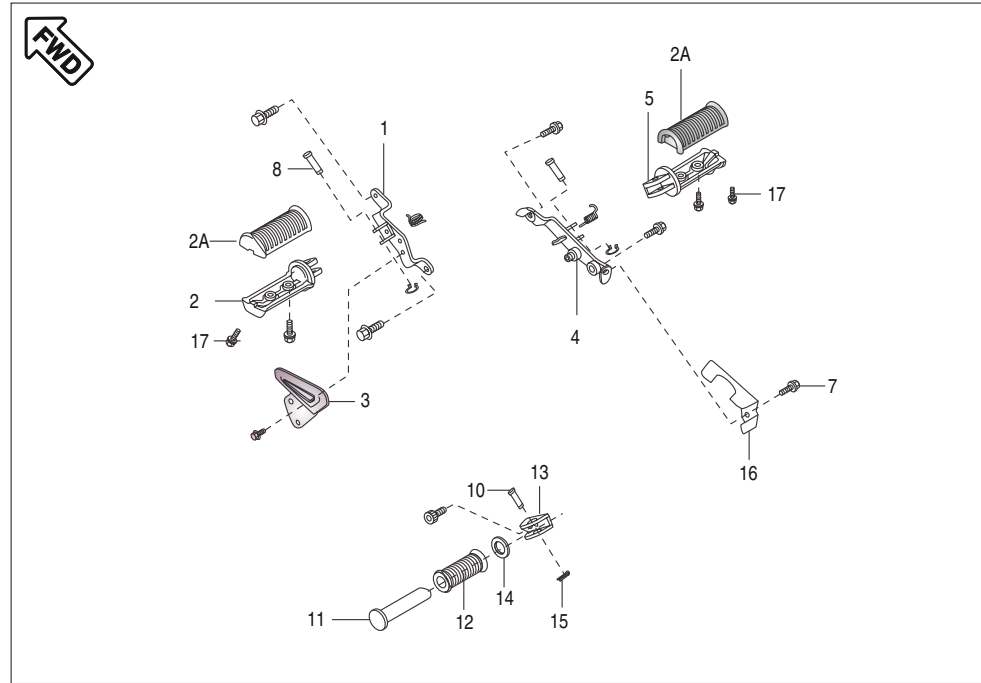

No.	Part No.	Description	Qty/ Veh.	Remarks
1	DV 1610 46	Holder Step Front LH	1	N.I
2	PD 1130 00	Footrest Rider LH - Avenger	1	
2A	PD 1130 03	Rubber Rider Step	2	
3	PD 2312 06	Guard Step LH	1	
4	JM 1610 37	Holder Step Front RH	1	
5	PD 1130 01	Footrest Rider RH - Avenger	1	
6	36 DV00 05	Kit Hardware Holder Step Front	1	
7	DG 1611 53	Bolt socket	2	
8	DG 1611 45	Pin	2	
10	DG 1611 89	Pin	2	
11	PD 1130 02	Step Rubber Rear	2	
12	PD 1130 04	Rubber Main Step	2	
13	52 DV 00 24	Holder Step Rear	2	
14	DG 1611 50	Washer	2	
15	39 0146 08	Split Pin	2	
16	PD 2312 05	Guard Step RH	1	
17	KA CF06 12	Bolt	4	

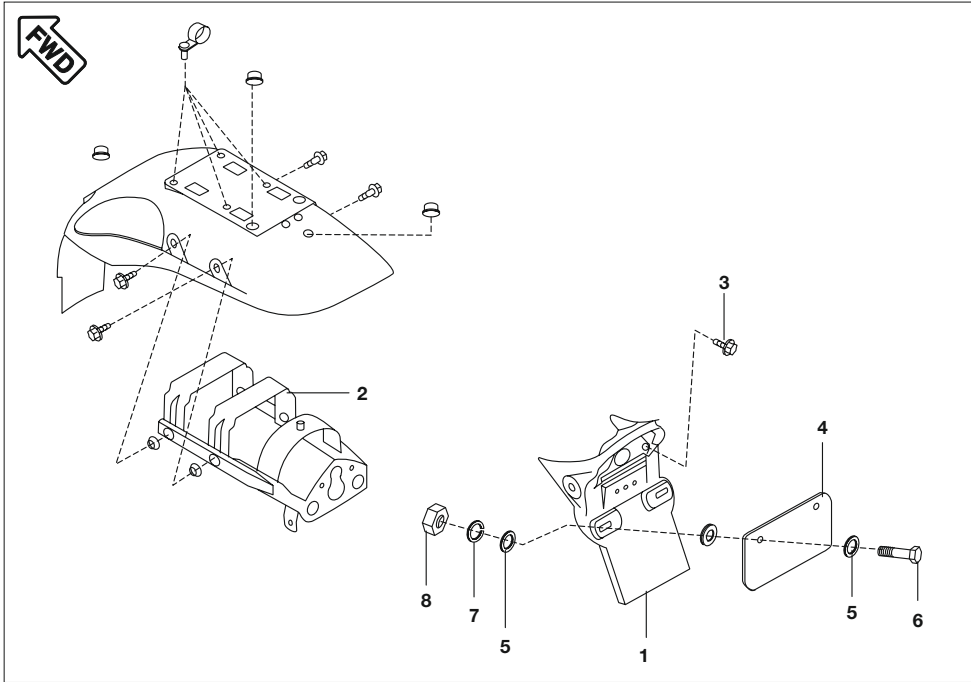

No.	Part No.	Description	Qty/ Veh.	Remarks
1	DG 1612 67	Flap	1	
2	DG 1612 06	Stay rear fender	1	
3	DG 1611 10	Bolt	2	
4	DP 1611 45	Number Plate	1	
5	39176511	Plain Washer	4	
6	39 1943 04	Hex. head Bolt	2	
7	39 0790 12	Spring Washer	2	
8	39 0291 15	Hex. Nut	2	
9	DF 1612 48	Bkt. Rear Number Plate	1	N.I.
	DZ 1612 65	Bkt. Rear Number Plate	1	Ref. Cir. IB-150

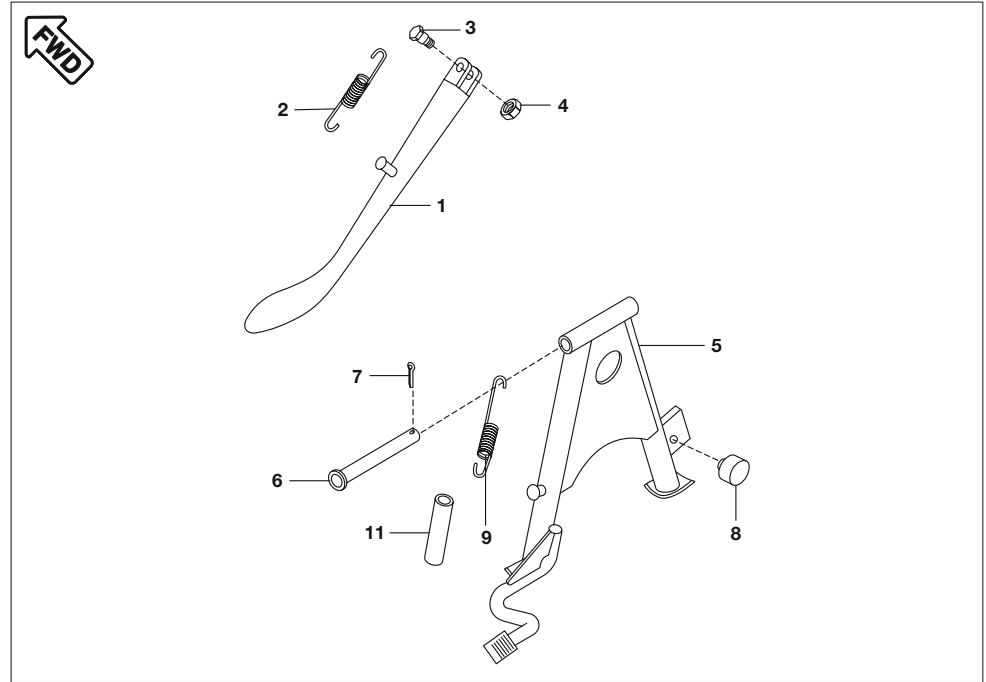

No.	Part No.	Description	Qty/ Veh.	Remarks
1	DV 1610 17	Side Stand	1	
2	DG 1612 19	Spring	1	
3	DG 1611 29	Bolt	1	
4	DD 1610 71	Lock Nut	1	
5	DV 1610 33	Stand Centre	1	
6	DG 1612 30	Shaft Stand	1	
7	39 0797 08	Pin Cotter	1	
8	DG 1611 24	Damper	1	
9	DV 1610 60	Spring	1	
10	39 2423 11	Plain washer	1	
11	DH 1611 45	Cover Spring main stand	1	

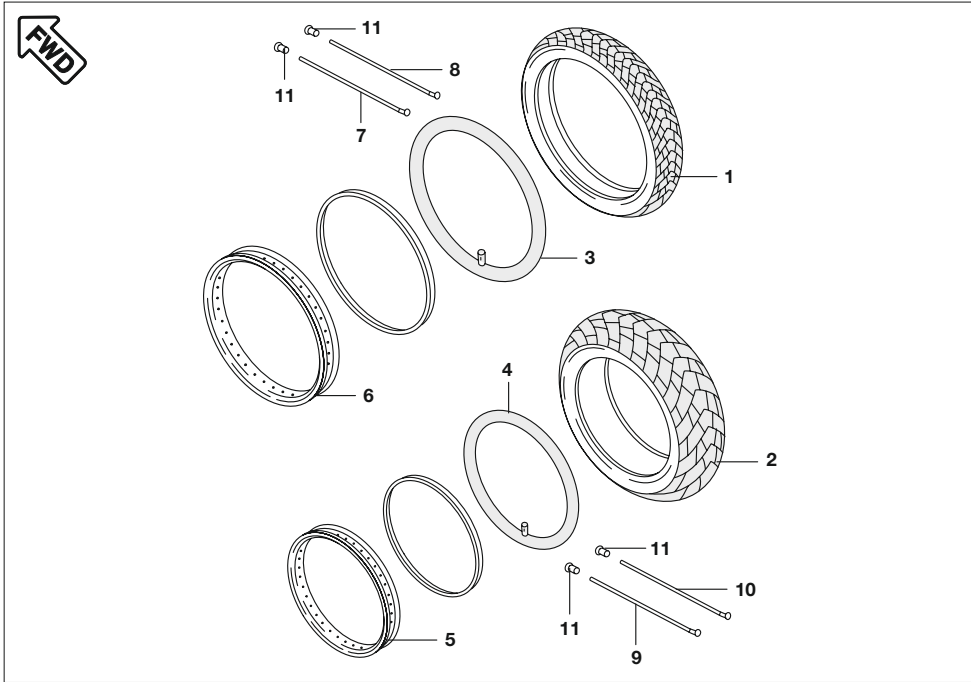

No.	Part No.	Description	Qty/ Veh.	Remarks
1	DG 1510 97	Tyre Front	1	} N.S Proprietary Items N.S Not to Service } N.S
2	DG 1510 70	Tyre Rear	1	
3	DG 1510 21	Tube for Tyre Front	1	
4	DG 1510 71	Tube for Tyre Rear	1	
5	DG 1510 94	Rim Rear	1	
6	DG 1510 93	Rim Front	1	
7	DG 1510 25	Spoke Inner Front	18	
8	DG 1510 75	Spoke Inner Rear	18	
9	DG 1510 26	Spoke Outer Front	18	
10	DG 1510 76	Spoke Outer Rear	18	
11	16 1510 66	Nipple Spoke	72	
12	DG 1511 00	Tyre with Tube Front	1	
13	DG 1510 69	Tyre With Tube Rear	1	

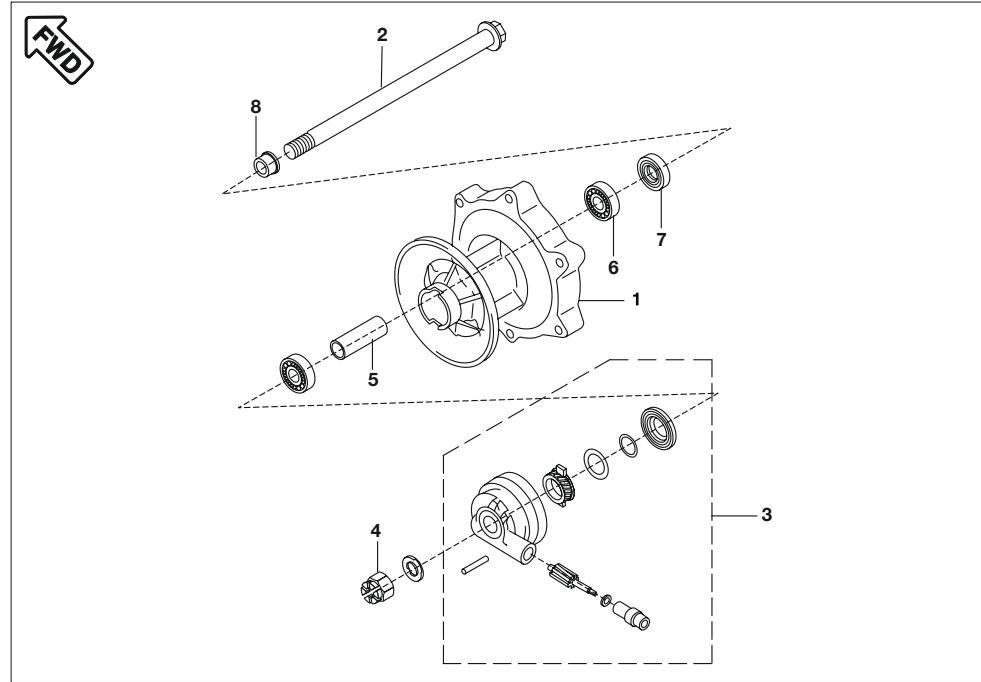

No.	Part No.	Description	Qty/ Veh.	Remarks
1	DG 1510 03	Drum Front Brake	1	
2	DG 1510 06	Axle, Front	1	
	DH 1510 14	Axle, Front	1	N.S alt for DG 1510 06
3	DG 1510 09	Case Assly Meter Gear	1	
	JZ 1316 05	Case Assly Meter Gear	1	Ref. Cir. D-47
4	DH 1710 19	Nut Castle	1	
5	DG 1510 04	Collar	1	
6	39 2241 20	Ball Bearing	2	
7	DG 1510 05	Seal oil	1	
8	DG 1510 07	Collar Front Axle	1	

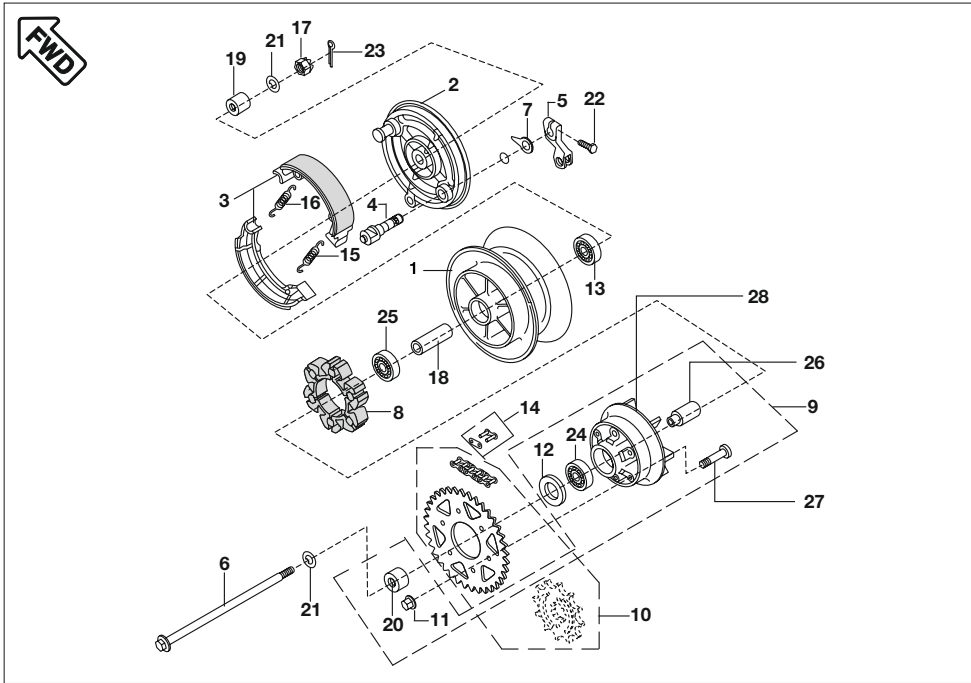

No.	Part No.	Description	Qty/ Veh.	Remarks
1	DG 1510 84	Drum Rear Brake	1	
2	DG 1510 81	Panel Assly Brake Rear	1	N.S
3	DG 1510 96	Shoe Brake Rear (Pair)	1	
4	DG 1510 59	Cam Brake	1	
5	DG 1510 60	Lever Brake Cam	1	
6	JM 1510 05	Axle Rear	1	
7	30 1510 09	Indicator Brake Shoe	1	N.S
8	30 1510 76	Damper Rear Hub Shock	1	
9	PD 1312 01	Coupling Assly Rear Hub	1	
10	36 JM00 03	Chain - Sprocket - Kit	1	Refer Page No. 63
11	DG 1510 66	Nut Flanged lock	6	
12	30 1510 82	Seal Oil	1	
13	39 2242 20	Bearing Ball	1	
14	DG 1510 95	Joint Chain	1	N.S
15	DG 1510 58	Spring Brake Shoe	1	

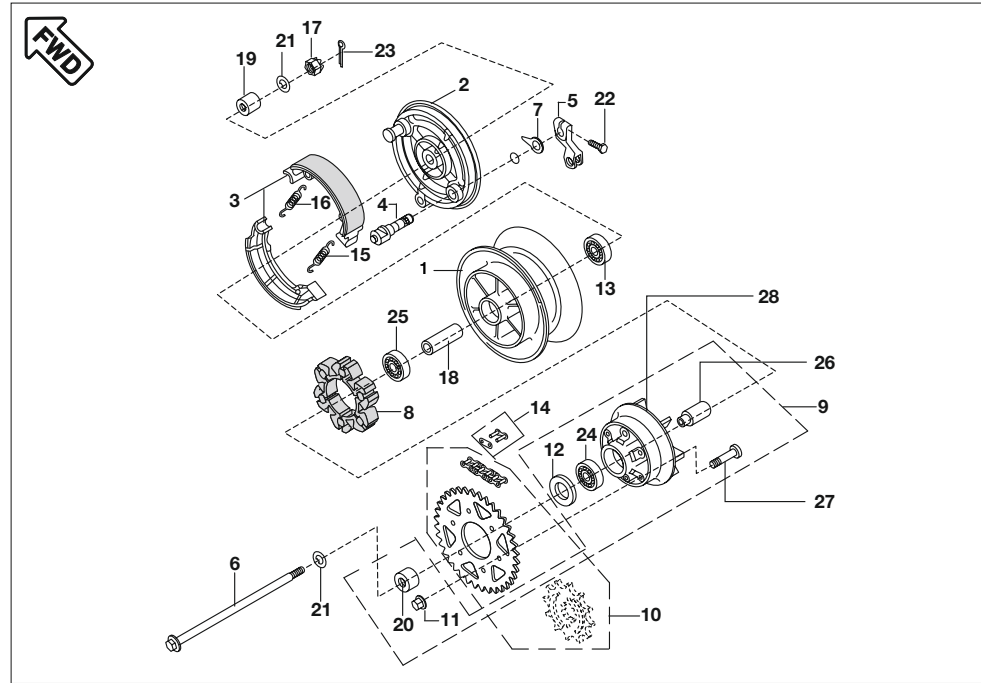

No.	Part No.	Description	Qty/ Veh.	Remarks
16	30 1510 69	Spring Brake Shoe	1	
17	39 0800 15	Nut Castle	1	N.S
18	DG 1510 85	Collar Rear Brake Drum	1	N.S
19	DG 1510 67	Collar Rear Axle	1	
20	DG 1510 62	Collar Rear Hub Coupling	1	
21	DG 1510 08	Washer	2	
22	39 1916 04	Bolt Upset	1	N.S
23	39 0148 08	Split Pin	1	N.S
24	39 2240 20	Bearing Ball	1	
25	39 2241 20	Bearing Ball	1	
26	DG 1510 65	Sleeve	1	
27	DG 1510 68	Bolt	6	
28	DV 1510 05	Caupling	1	

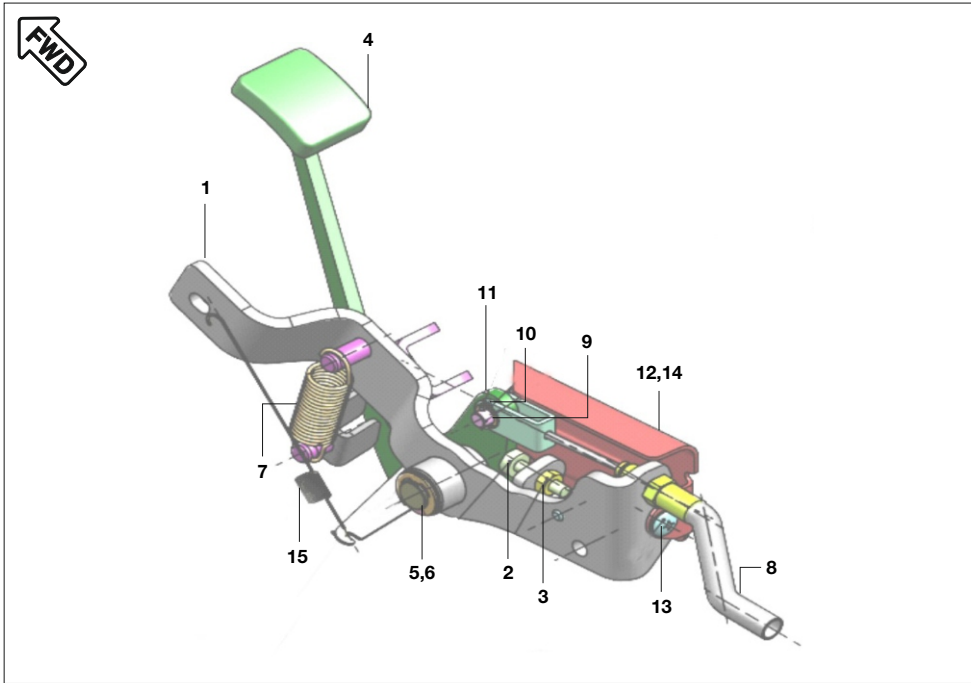

No.	Part No.	Description	Qty/ Veh.	Remarks
1	JM 1610 37	Stay RH assly.	1	
2	KA AC06 30	Hexagon head bolt M6X1	1	N.S
3	39 0292 15	Hexagon Nut-M6X1	1	
4	JM 1910 11	Lever Brake	1	
5	39 0805 11	Washer	1	
6	LE C000 01	Circlip E type	1	
7	JM 1910 12	Spring	1	
8	JM 1910 13	Rear brake cable	1	
9	DG 1910 51	Pin	1	
10	DG 1910 66	Washer	1	N.S
	39 1211 11	Washer	1	Alt for DG 1910 66
	39 0200 11	Washer	1	alt for DG 1910 66
11	39 0146 08	Slip Pin	1	
12	JM 1910 15	Guard Brake pedal	1	
13	KB UA06 12	Mushroom Head screw - M6-L12	1	
14	LB U000 08	Mushroom Head screw - M6-L40	1	
15	JM 1910 14	Spring Brake Switch	1	

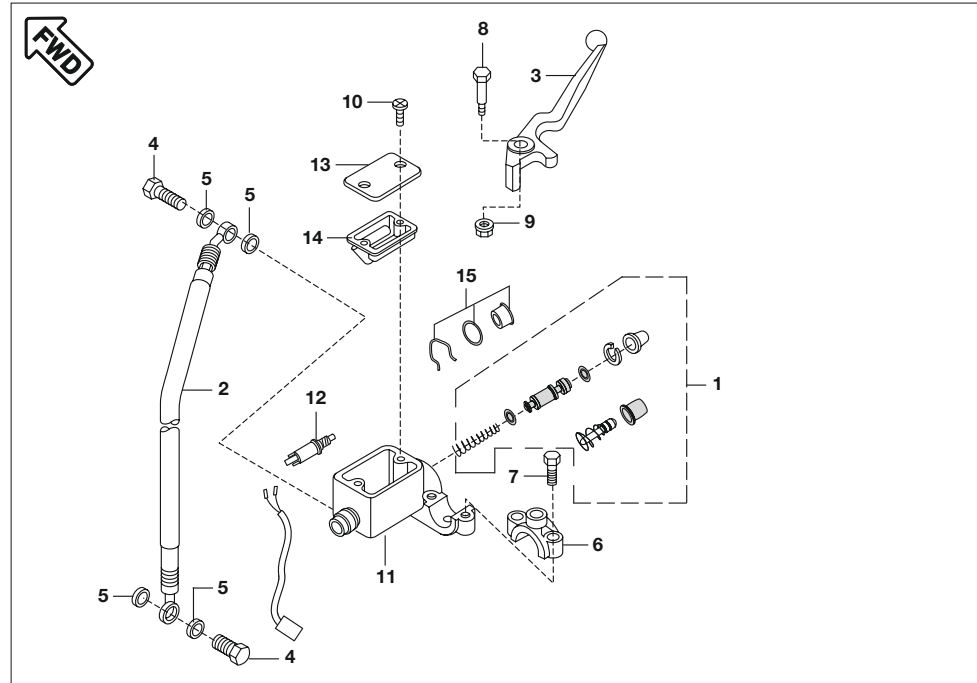

No.	Part No.	Description	Qty/ Veh.	Remarks
1	DE 1510 15	Major Kit - Master Cylinder	1	
2	DG 0100 14	Hose Brake Front	1	
3	DV 1910 07	Lever Grip RH	1	
4	DE 1910 11	Banjo Bolt	2	
5	DE 1910 10	Washer Copper	4	
6	DK 1810 52	Clamp Holder RH	1	
7	DE 1910 34	Bolt	2	
8	DE 1910 31	Bolt Front Brake Lever	1	
9	DE 1910 32	Nut Flanged	1	
10	DE 1910 30	Screw	2	
11	DJ 1910 32	Cylinder Master	1	
12	DJ 2011 09	Front brake switch	1	
13	DE 1910 29	Reservoir Cover	1	
14	DE 1910 28	Diaphragm	1	
15	DE 1910 36	Window for Master Cylinder	1	



EMPTY PAGE

No.	Part No.	Description	Qty/ Veh.	Remarks

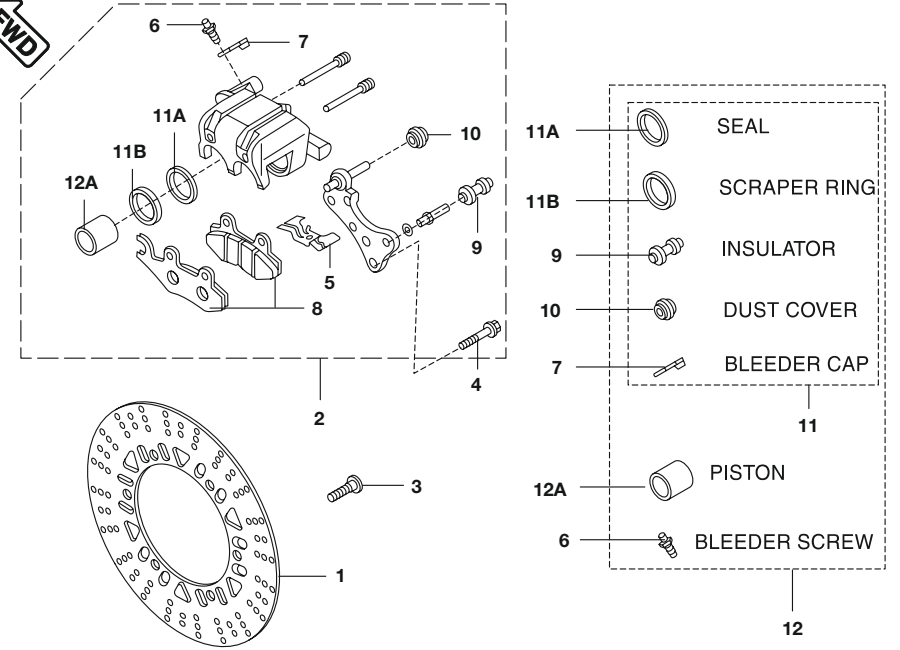

No.	Part No.	Description	Qty/ Veh.	Remarks
1	DG 1511 02	Disc, Front	1	
2	DG 1510 89	Caliper Assly. Front	1	
	DE 1510 14	Caliper Assly. Front	1	alt for DG 1510 89
3	DG 1510 49	Bolt, Disc Plate	6	
4	DG 1510 88	Bolt Flanged	2	N.S
5	DE 1510 48	Spring Pad	1	
6	DE 1510 46	Bleeder Screw	1	
7	DE 1510 47	Bleeder Cap	1	
8	DE 1510 37	Disc Pad Set	1	
9	DE 1510 43	Insulator	1	
10	DE 1510 45	Dust cover	1	
11	DE 1510 51	Minor Kit - Caliper	1	
	36 Dk00 65	Minor Kit - Caliper	1	alt for DE 1510 51
12	DE 1510 52	Major Kit - Caliper	1	

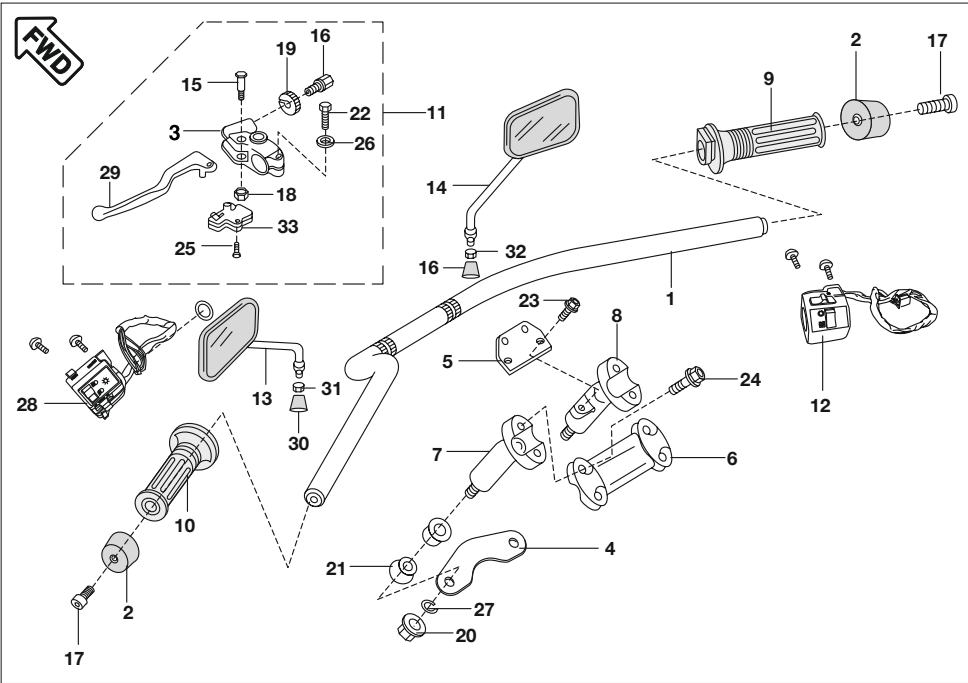

No.	Part No.	Description	Qty/ Veh.	Remarks	
1	JM 1810 08	Handle	1	N.S	
2	DV 1810 03	Weight, Handle	2		
3	DG 1910 80	Holder Clutch Lever	1		
4	JM 1810 07	Plate Wind Shield	1		
5	DV 1810 08	Bracket speedometer	1		
6	DG 1810 67	Holder Handle Upper	1		
7	DG 1810 70	Holder Handle Lower LH	1		
8	DG 1810 71	Holder Handle Lower RH	1		
9	DH 1910 08	Grip RH	1		
10	DH 1910 07	Grip LH	1		
11	DG 1910 10	Lever Assly. Grip Clutch LH	1		
12	PD 4014 01	Control Switch RH	1		for Argentina
	PD 4014 09	Control Switch RH	1		
13	JM 2210 01	Mirror Assly LH	1		
14	JM 2210 02	Mirror Assly RH	1		
15	DG 1910 13	Bolt Clutch Lever	1		
16	30 1910 24	Screw cable Adjust	1		
17	39 2427 04	Allen key bolt	2		

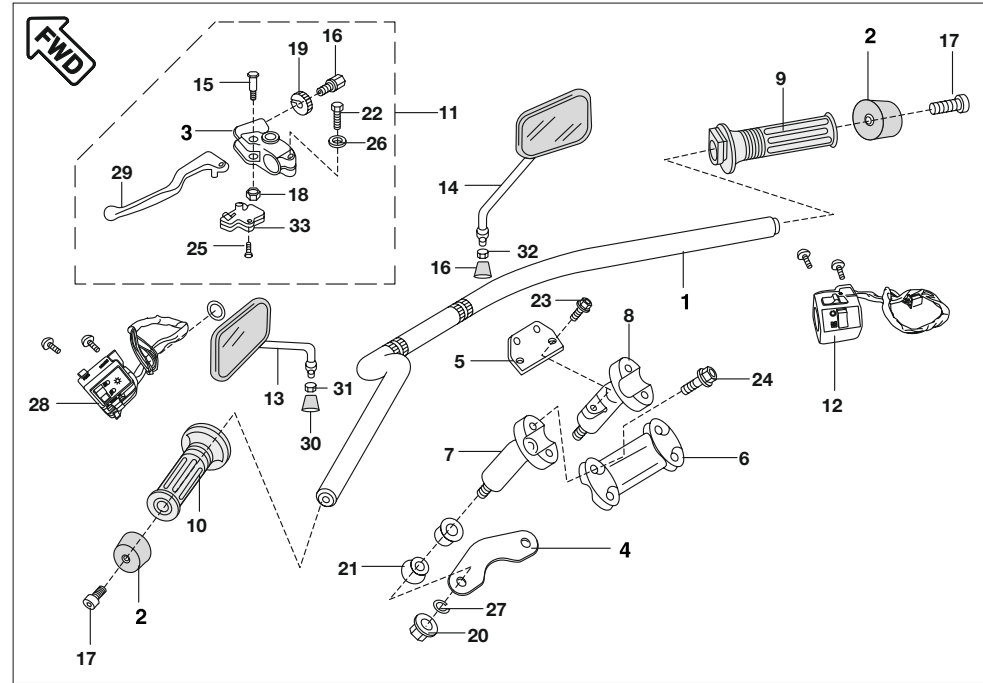

No.	Part No.	Description	Qty/ Veh.	Remarks
18	DG 1910 14	Nut Lock	1	
19	30 1910 17	Nut Cable Adjust Lock	1	
20	DG 1810 87	Nut Cap	2	
21	DG 1810 54	Damper	4	
22	39 1993 04	Bolt Upset	1	N.S
23	39 1953 04	Bolt Flanged small	2	N.S
	39 1944 04	Bolt Flanged small	2	alt for 39 1953 04
24	39 1952 04	Bolt Flanged small	4	N.S
	59 0400 48	Bolt Flanged small	4	alt for 39 1952 04
	39 1769 04	Bolt Flanged small	4	alt for 39 1952 04
25	39 1995 01	Screw CSK Cross	2	N.S
26	39 1506 11	Washer Plain small	1	N.S
27	39 0789 12	Washer spring	2	
28	PD 4014 04	Housing Assly. Control LH	1	
29	DG 1910 12	Lever Grip LH	1	N.S
30	JM 2210 04	Mirror Rubber boot	2	N.S
31	JM 2210 05	Nut Mirror LH	1	
32	JM 2210 06	Nut Mirror RH	1	
33	DG 2010 30	Clutch Switch	1	
34	JM 1910 10	Lever Boot	1	N.I

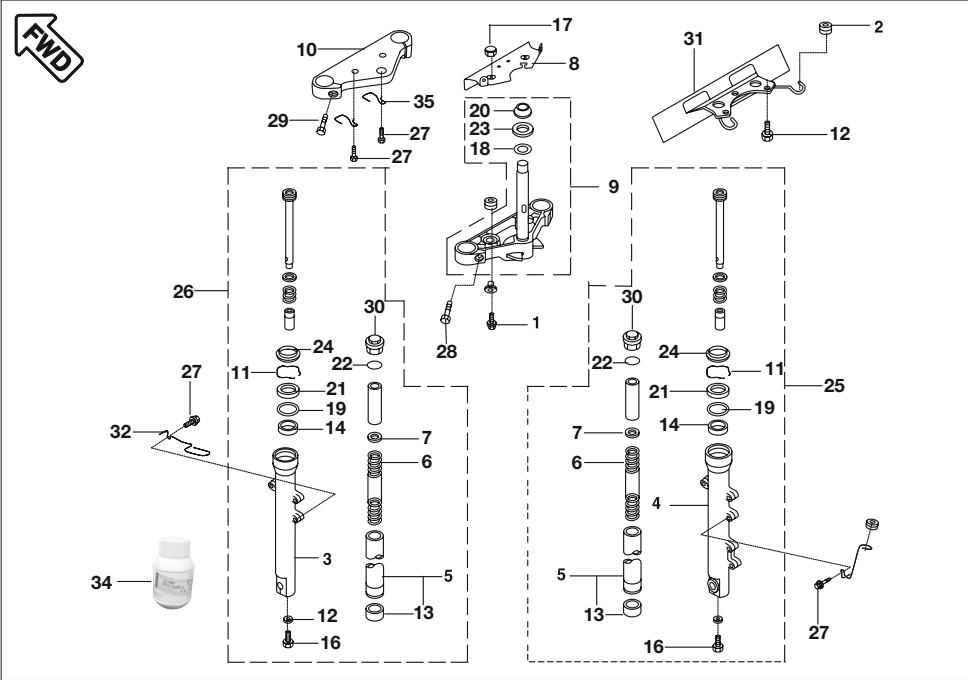

No.	Part No.	Description	Qty/ Veh.	Remarks
1	39 1951 04	Bolt Flanged small	2	
	39 1956 04	Bolt Flanged small	2	alt for 39 1951 04
2	DG 1810 34	Grommet, Hose Clamp	2	
3	DG 1810 12	Pipe - Left Fork Outer	1	
4	DG 1810 89	Pipe - Right Fork Outer	1	
5	DV 1810 13	Pipe, Fork Inner	2	
6	DG 1810 14	Spring Front Fork	2	N.S
7	DG 1810 15	Seat Fork Spring	2	N.S
8	DG 1810 93	Cover Fork	1	
9	DG 1810 95	Holder Fork Under	1	
10	DG 1810 91	Holder Fork Upper	1	
11	DG 1810 22	Ring, Oil Seal Stopper	2	N.S
12	39 1943 04	Bolt Flange	3	
13	DG 1810 11	Bushing - Front Fork, Inner Pipe	2	
14	DG 1810 13	Bushing - Front Fork, Outer Tube	2	
15	DV 1810 01	Fork Front assly.	1	Includes Sr.No. 9,10,25 & 26

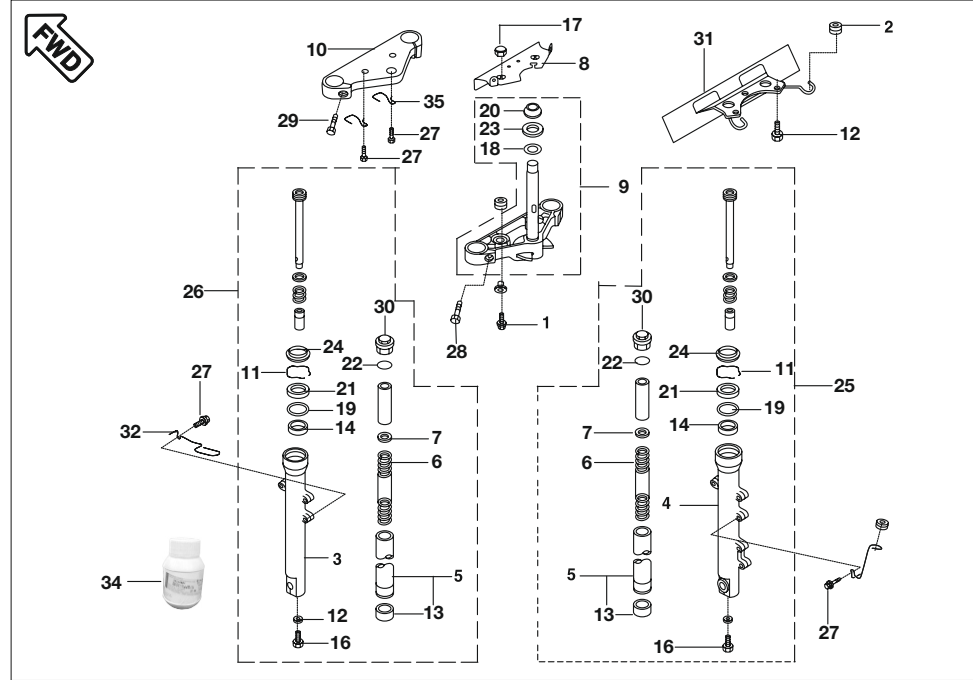

No.	Part No.	Description	Qty/ Veh.	Remarks
16	DG 1810 27	Bolt, Fork Cylinder	2	N.S
17	DG 1810 85	Nut, Cap	2	N.S
18	DG 1810 03	Washer	1	
19	DG 1810 24	Spacer	2	
20	DG 1810 05	Race, Steering Stem Bearing	1	
21	DG 1810 23	Seal Oil, Fork Outer Tube	2	
22	DG 1810 26	Ring 'O' Fork Top	2	N.S
23	DG 1810 04	Seal Oil, Steering Stem	1	
24	DG 1810 21	Seal, Fork Outer Tube	2	
25	DG 1810 88	Damper assly. RH	1	
26	DG 1810 09	Damper assly. LH	1	
27	DG 1810 36	Bolt	4	N.S
28	DG 1810 06	Bolt Socket	2	N.S
29	DG 1810 08	Bolt	2	
30	DG 1810 25	Bolt Fork Top	2	N.S
31	DP 1611 44	Plate Number Front	1	
32	DG 1810 41	Clamp S' cable clamp	1	
34	36 3140 04	Front Fork oil Bottle 160ml	1	N.S
35	DG 1810 40	Clamp	2	

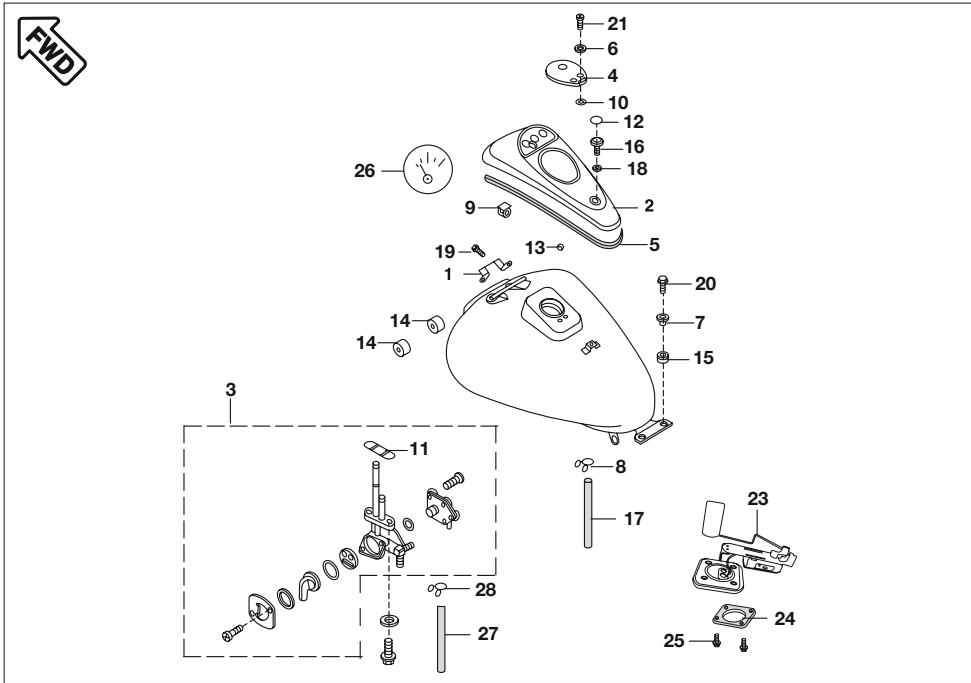

No.	Part No.	Description	Qty/ Veh.	Remarks
1	DG 1410 20	Bracket Fuel Tank Cover	1	
2	PD 1710 00	Cover Assly. Fuel Tank	1	
3	DK 1410 01	Fuel Cock Assly.	1	N.S
	DJ 1410 56	Fuel Cock Assly.	1	alt for DK 1410 01
4	DG 1410 52	Cap Tank Fuel	1	
5	DG 1410 59	Trim	1	
6	39 2179 24	Washer	2	
7	30 2110 05	Collar	2	
8	DG 1410 28	Clamp	1	
9	DG 1410 43	Clamp, Tube	1	N.S
10	30 1410 31	Ring 'O'	2	
11	30 1410 39	Ring 'O' Fuel Tap Packing	1	
12	DG 1410 24	Plug	2	
13	DG 1410 25	Damper	2	N.S
14	30 1410 26	Damper Fuel Tank	2	
15	DG 1410 19	Damper	2	

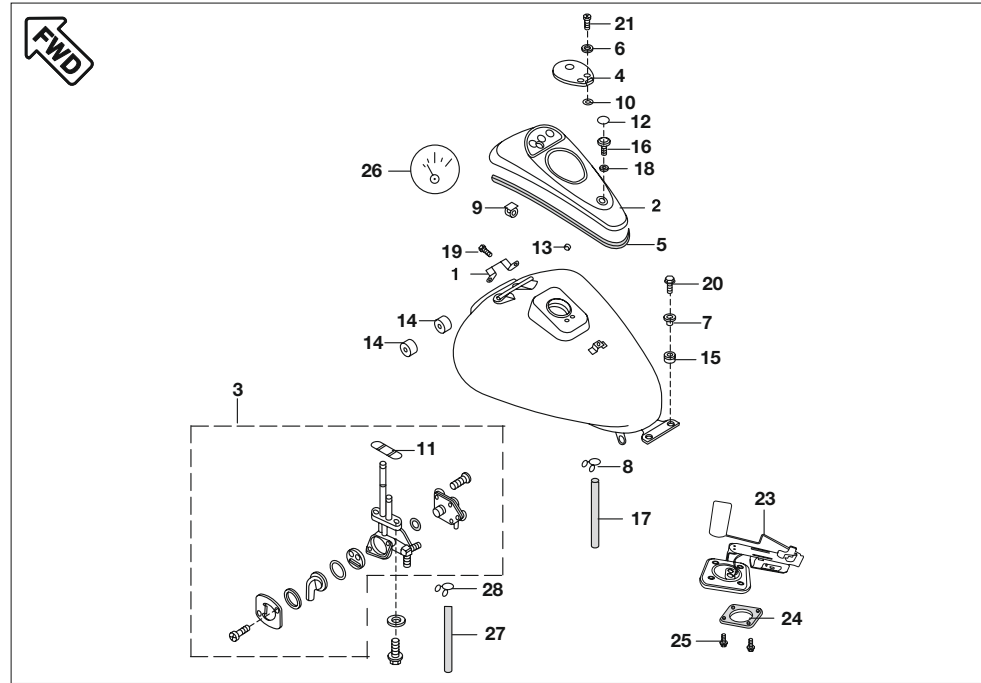

No.	Part No.	Description	Qty/ Veh.	Remarks
16	DG 1410 26	Bolt	2	
17	DG 1410 29	Tube	1	
18	DG 1410 27	Washer	2	
19	39 1912 04	Bolt Flanged	2	
	39 2453 04	Bolt Flanged	2	alt for 39 1912 04
20	39 1913 04	Bolt Flanged	2	
21	39 0761 01	Screw Pan Cross	2	
22	JM 1410 02	Cover with fuel gauge	1	
23	JM 2010 04	Fuel gauge sender	1	
24	30 1410 28	Gasket Tank Unit	1	N.S
25	30 1410 32	Bolt for tank Unit	4	
26	PD 4026 00	Fuel gauge (Meter)	1	
27	DJ 1410 06	Fuel Cock Tube	1	
28	30 1410 15	Clip for Tube	1	
	DK 1410 41	Clip for Tube	1	alt for 30 1410 15

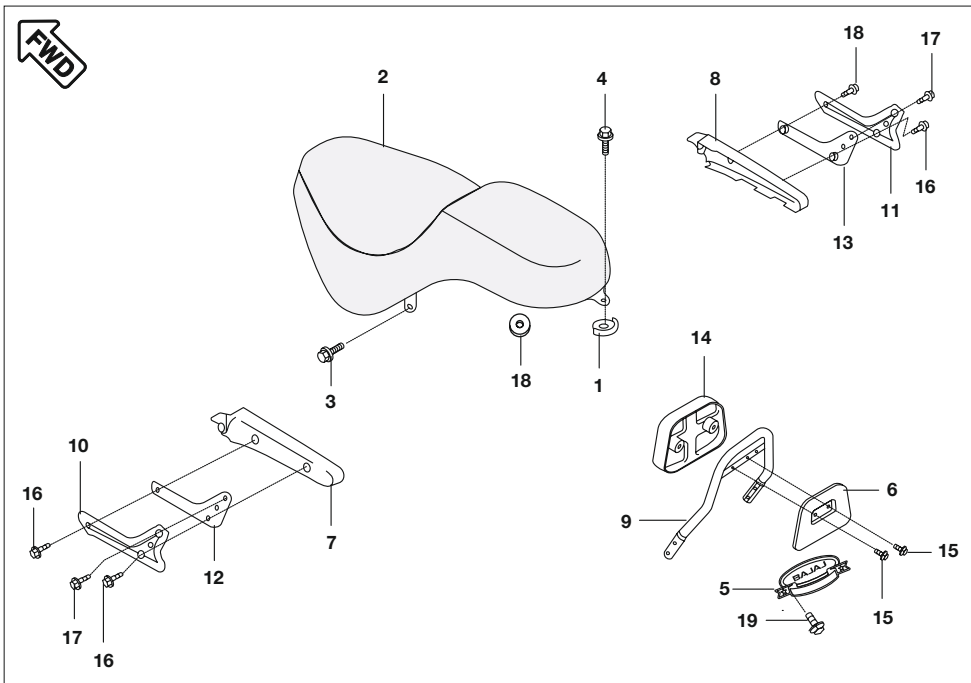

No.	Part No.	Description	Qty/ Veh.	Remarks
1	DG 2110 07	Plate Seat	1	
2	DG 2110 01	Seat Assly.	1	
3	39 1942 04	Bolt Flanged	2	
4	39 1949 04	Bolt Flanged Small	1	N.S
	39 1943 04	Bolt Flanged Small	1	alt for 39 1949 04
5	DV 2210 01	Emblem Back Rest	1	
6	DG 2210 28	Cover, Pad	1	
7	DG 1611 82	Cover, Rear Fender LH	1	
8	DG 1611 83	Cover RH	1	
9	DG 2210 22	Grip frame rear	1	
10	DG 2210 31	Cover Grip frame LH	1	
11	DG 2210 32	Cover Grip frame RH	1	
12	DG 2210 16	Grip frame LH	1	
13	DG 2210 19	Grip frame RH	1	
14	DG 2210 27	Pad seat	1	
15	39 2147 04	Bolt Upset	2	
16	39 1952 04	Bolt flanged Small	4	alt 39176904
17	39 1951 04	Bolt Flanged Small	4	N.S
	39 1956 04	Bolt Flanged Small	4	alt for 39 1951 04
18	DG 2110 06	Seat Damper	1	
19	DG 2210 41	Screw emblem	2	

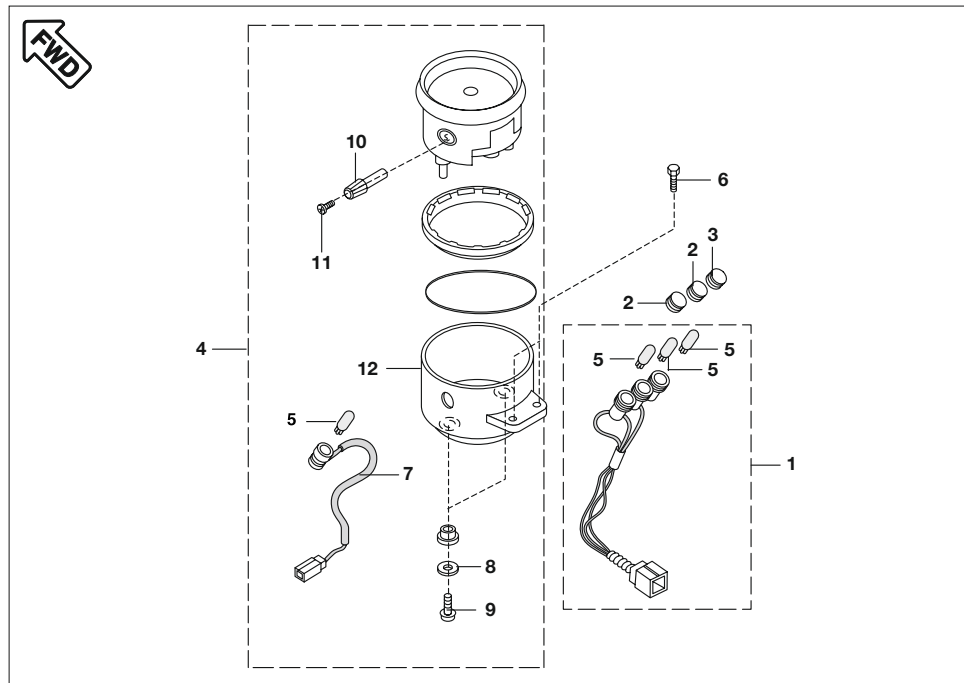

No.	Part No.	Description	Qty/ Veh.	Remarks
1	DG 1910 69	Lamp Assly	1	N.S
2	DG 1910 03	Lens - TPI & Neutral	2	
3	DG 1910 05	Lens - Hi Beam	1	N.S
4	DV 1910 08	Meter Assly.	1	
5	GF 2010 50	Lamp 12V - 1.7 W	4	N.S
5A	DL 1910 20	Lamp 12V - 3 W	1	
	DH 1910 37	Lamp 12V - 3 W	1	alt for DL 1910 20
6	39 1953 04	Bolt Flanged Small	2	For Meter Assly N.S.
	39 1944 04	Bolt Flanged Small	2	alt for 39 1953 04
7	DG 1910 93	Assly. lamp holder	1	N.S
8	DG 1910 95	Washer	2	For Machine mtg. N.S
9	DG 1910 96	Screw pan head	2	For Machine mtg. N.S
10	DG 1910 97	Trip meter knob	1	N.S
11	DG 1910 98	Screw (Knob reset trip meter)	1	N.S
12	JM 2010 19	Loose cover speedo	1	

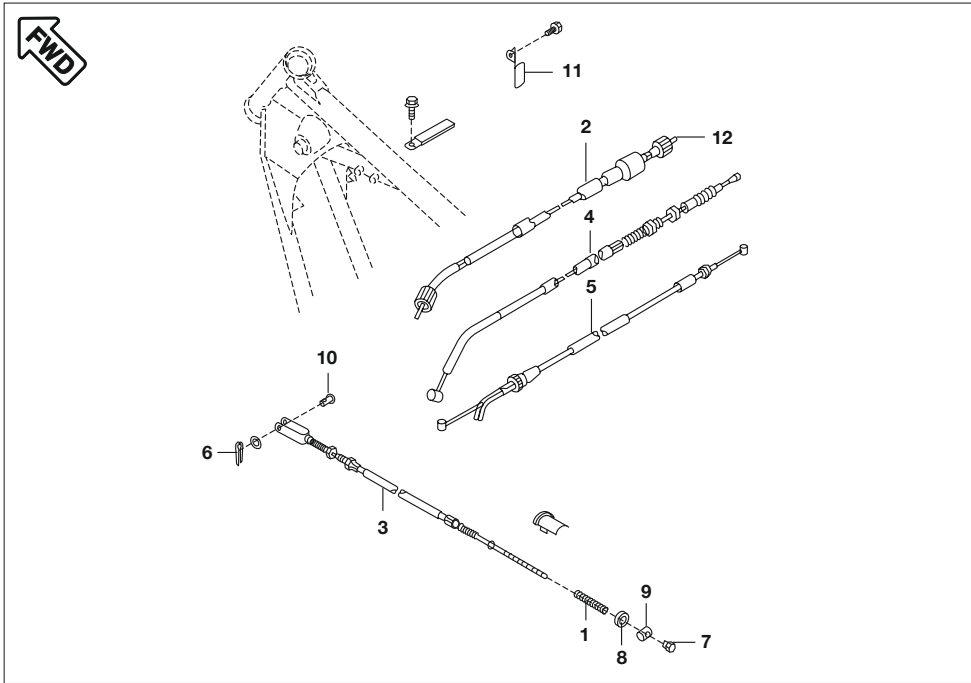

No.	Part No.	Description	Qty/ Veh.	Remarks
1	30 1910 35	Spring, Brake Rod	1	
2	JM 1910 07	Cable- Speedometer	1	
	PD 4022 07	Cable- Speedometer	1	Ref. Cir. D-47
3	JM 1910 13	Cable Brake	1	
4	DV 1910 02	Cable Clutch	1	
5	DV 1910 04	Cable Throttle	1	
6	39 0146 08	Pin Cotter	1	
7	30 1910 36	Nut Brake Rod	1	
8	DG 1910 66	Washer	1	N.S
9	DG 1910 50	Pin Brake Rod	1	
10	DG 1910 51	Pin	1	
11	DV 1910 06	Clamp Clutch cable	1	
12	DV 1910 07	Speedo Inner	1	
13	PD 1220 03	Torque Rod	1	N.S
14	PD 1220 04	Bolt Torque Rod	1	
15	39 0694 15	Nut	1	
16	39 0789 12	Spring Washer	1	
17	39 1540 11	Plain Washer	1	
18	39 0841 01	Screw CSK cross M5	1	Ref. Cir D-47 N.I N.S

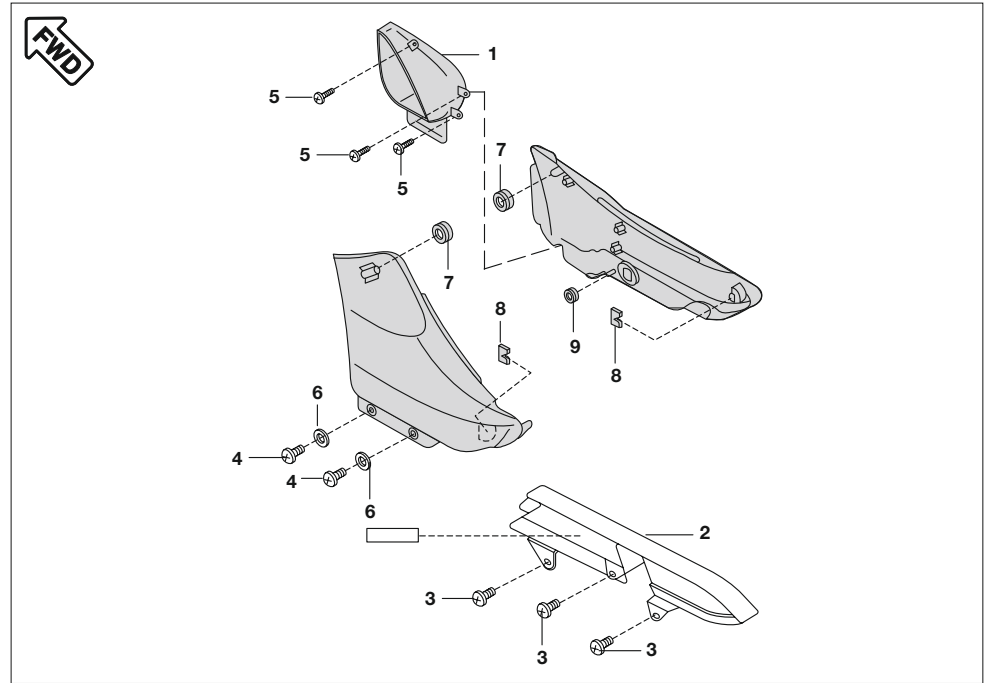

No.	Part No.	Description	Qty/ Veh.	Remarks
1	DG 1612 20	Cover Side RH Rear	1	
2	DG 1611 20	Case Chain	1	
3	DG 1611 21	Screw Tapping	3	
4	39 1076 01	Screw	2	
5	DG 1611 17	Screw	3	
6	31 1610 78	Washer	2	
7	DG 1611 18	Grommet	2	
8	DD 1610 22	Damper	2	
9	DG 1612 25	Damper	1	

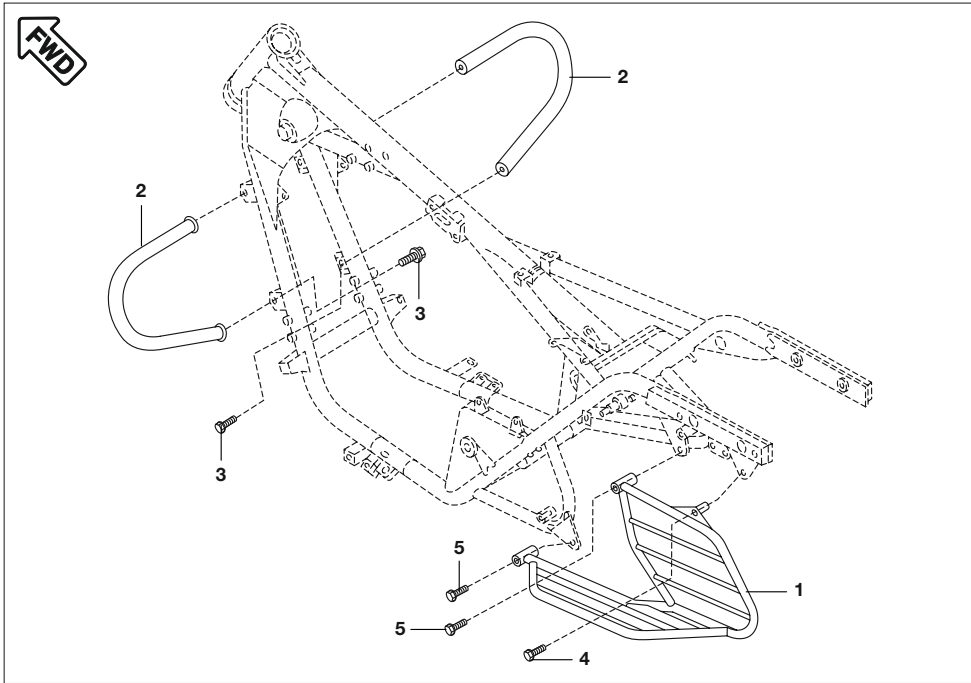

No.	Part No.	Description	Qty/ Veh.	Remarks
1	DG 2210 33	Guard Sari	1	
2	JM 1610 17	Guard- Front Bumper	2	
3	39 1940 04	Bolt Flanged	4	
4	39 1814 04	Bolt Flanged	1	
5	39 1941 04	Bolt Flanged M8	2	

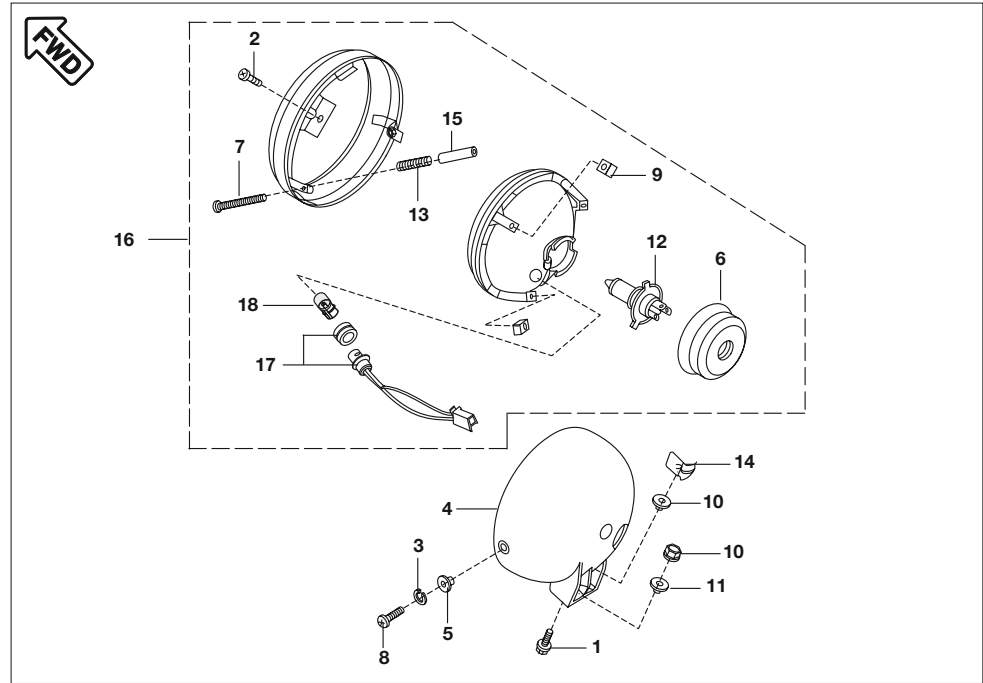

No.	Part No.	Description	Qty/ Veh.	Remarks
1	39 2029 04	Bolt Flanged	2	
2	DG 2010 66	Screw Pan Cross	1	For holding head light
3	39 0790 12	Spring Washer	2	
4	DG 2010 10	Body Comp. Head Lamp	1	
5	30 2010 33	Washer	2	For mtg. Head light on body N.S
6	DG 2010 68	Cap for Head lamp	1	
7	DG 2010 69	Screw Focus Adjust	2	N.S
8	DG 2010 43	Screw	2	For mtg. Head light on body N.S
9	DG 2010 70	Nut	1	For holding head light
10	DG 1910 64	Nut Flanged	1	N.S
11	DG 2010 57	Collar	2	For Head Light Mtg.
12	DG 2010 71	Lamp 12V - 60/55W	1	
13	DG 2010 72	Spring Focus Adjust	2	
14	DG 2010 12	Clamp Harness	1	
15	DG 2010 73	Tube	2	
16	DV 2010 10	Head Lamp Assly.	1	
17	DG 2010 74	Wire assly. parking	1	
18	DG 2010 40	Lamp 12V - 4W	1	Imported bulb 'E' mark

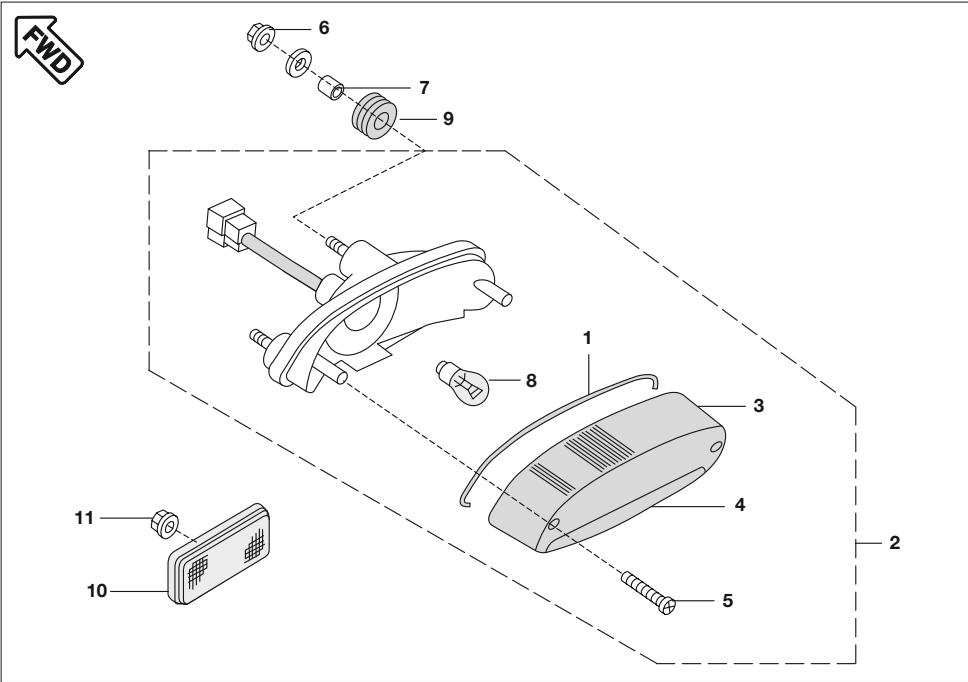

No.	Part No.	Description	Qty/ Veh.	Remarks
1	DG 2010 75	Gasket Tail Lamp Lens	1	N.S
2	PD 4010 00	Tail Lamp Assly.	1	
	PD 4010 01	Tail Lamp Assly with Pig Tail	1	
3	DG 2010 49	Lens Tail Lamp- Red	1	
4	DG 2010 50	Lens Tail Lamp- Clear	1	
5	DG 2010 76	Screw Tapping	2	N.S
6	DG 1910 64	Nut Flanged	3	N.S
7	31 2010 01	Collar	3	
8	AA 2012 27	Lamp 12V - 21/5W	1	
9	DG 2010 15	Damper	3	
10	DD 2010 02	Reflector Reflex	1	
11	39 1972 15	Nut Flanged	1b	

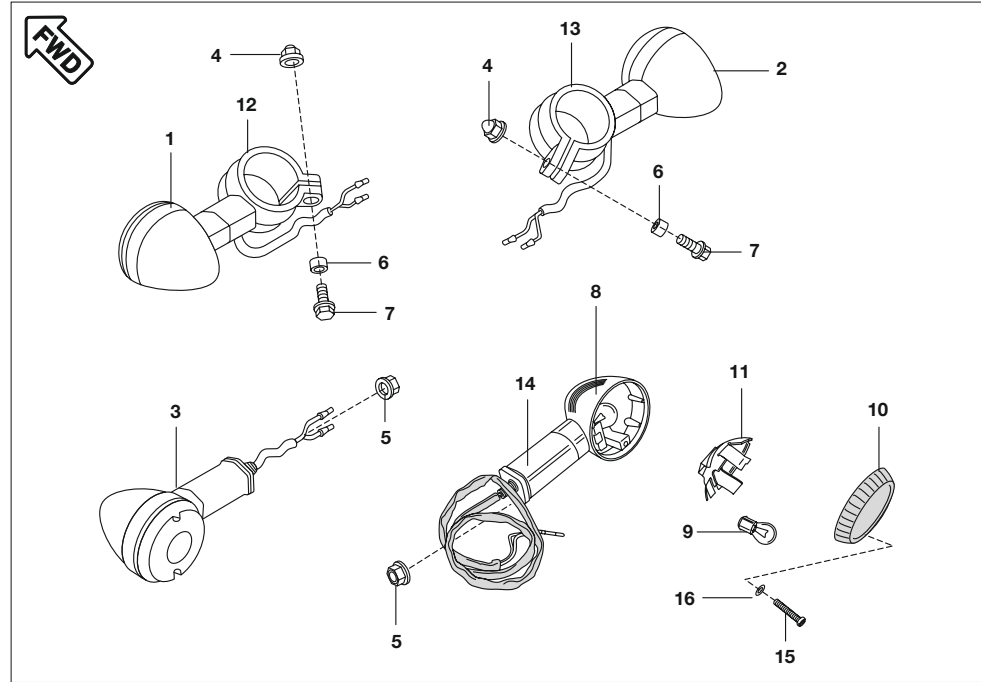

No.	Part No.	Description	Qty/ Veh.	Remarks
1	JM 2010 28	Lamp Assly Signal FR. LH	1	
2	JM 2010 29	Lamp Assly Signal FR. RH	1	
3	JM 2010 30	Lamp Assly Signal Rear. LH	1	
4	39 2124 15	Nut Cap	2	
5	39 1225 15	Nut Flanged	2	
6	31 2010 01	Collar	2	
7	39 1950 04	Bolt Flanged Small	2	
8	JM 2010 31	Lamp Assly. Signal Rear RH	1	
9	20 2010 51	Lamp 12V-10W	4	N.S
10	DG 2010 52	Lens Signal Light	4	N.S
11	DG 2010 53	Reflector Signal Light	4	N.S
12	DG 2010 54	Stay Signal Light Fr. LH	1	N.S
13	DG 2010 55	Stay Signal Light Fr. RH	1	
14	DG 2010 56	Stay Signal Light Rear	2	N.S
15	DG 2010 77	Screw Signal Light	8	N.S
16	DG 2010 78	Washer Signal Light Light	8	

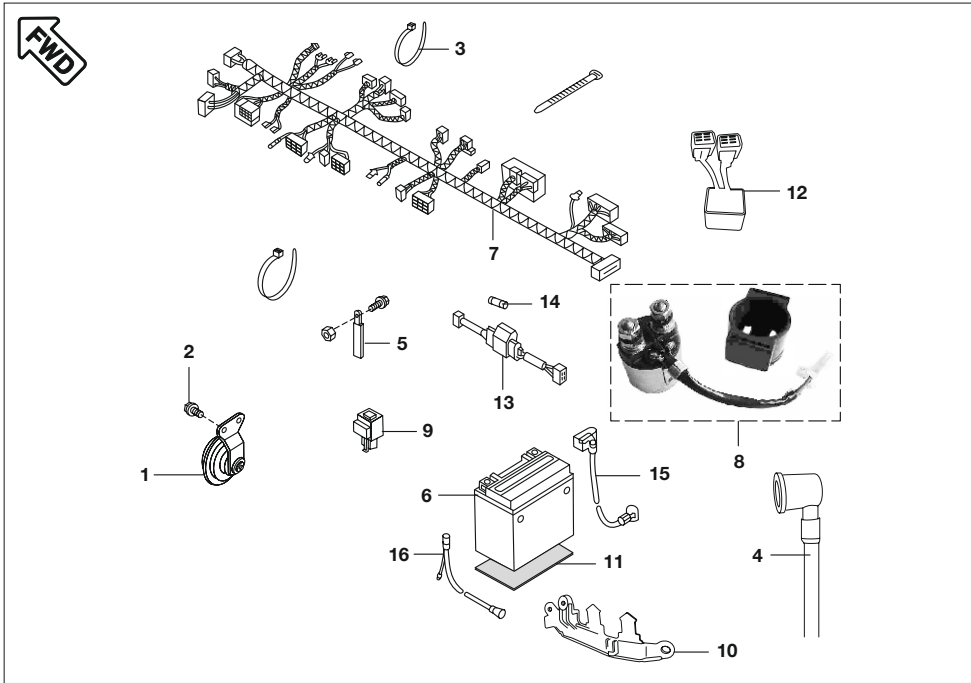

No.	Part No.	Description	Qty/ Veh.	Remarks
1	JM 2010 02	Horn	1	
2	39 1912 04	Bolt Flanged	2	
3	30 1910 48	Band	2	
4	JM 2010 32	Battery adapter with Tube	1	N.S
5	31 2010 21	Clamp wiring harness	1	
6	DJ 2011 26	Battery 12 V 9 Ah Dry Charged	1	N.S
7	PD 4022 00	Wiring Harness	1	
	PD 4022 02	Wiring Harness (Ign. switch Position Change)	1	from Chs. no. TCL16332
	PD 4022 09	Wiring Harness	1	Ref. Cir. IB -156
	PD 4022 08	Wiring Harness	1	For Argentina
	PD 4022 10	Wiring Harness(AHO)	1	Ref. Cir. IB -156
8	DV 2010 16	Starter Relay Assly.	1	
9	PD 4020 01	Relay Turn Signal	1	
10	DV 1610 36	Band Battery Bracket	1	
11	DG 2010 27	Mat Battery	1	
12	JB 4010 13	Head lamp Controller unit	1	N.S
13	DG 2010 32	Fuse assly.	1	
14	30 2010 85	Fuse	3	
15	JM 2010 12	Cable Assly. (Batt. to Starter Rly.)	1	
16	DV 2010 06	Cable Assly. (Battery to Earth)	1	

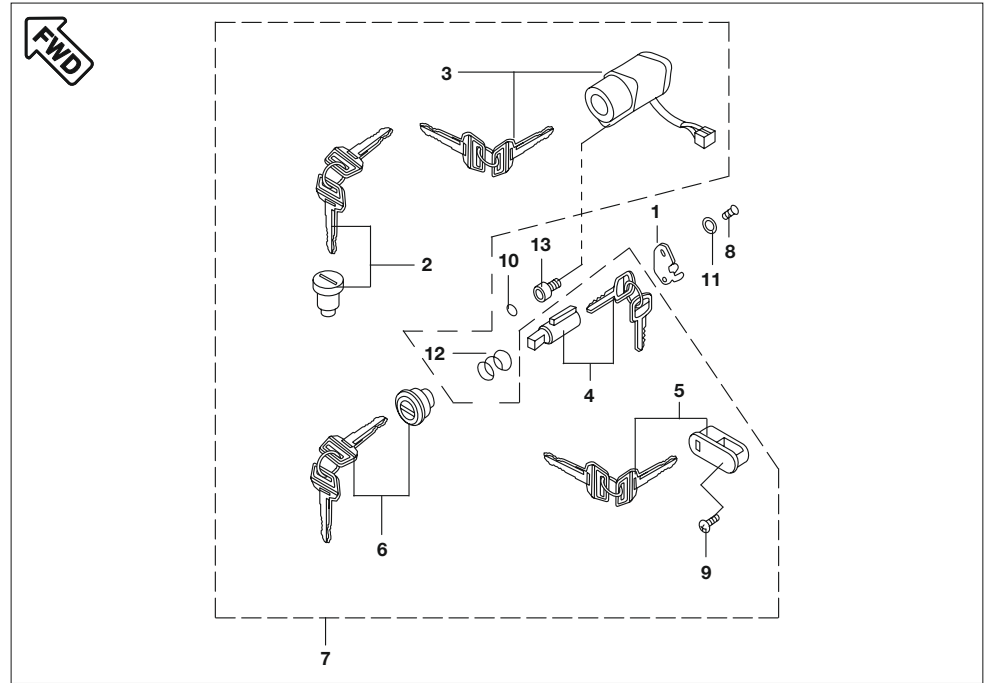

No.	Part No.	Description	Qty/ Veh.	Remarks
1	DG 1810 55	Cap, Steering Lock	1	
2	DG 1410 17	Rotor, Lock, Tank Cap	1	
3	PD 4014 00	Switch Assly. Ignition	1	
4	JM 1810 03	Lock Assly Steering	1	
5	DG 2210 09	Lock Assly Helmet	1	
6	DG 1611 68	Lock Assly Side Cover	1	
7	PD 4014 02	Lock Set (5 in 1)	1	
	PD 4014 08	Lock Set (5 in 1) (Ign. switch Position Change)	1	from Chs. no. TCL16332
8	DG 1810 57	Screw	1	
9	DG 2210 10	Screw	1	
10	DG 2010 23	Plug	1	
11	DG 1810 58	Washer Wave	1	
12	DG 1810 59	Spring Steering Lock	1	
13	39 1975 04	Bolt Socket	1	N.S

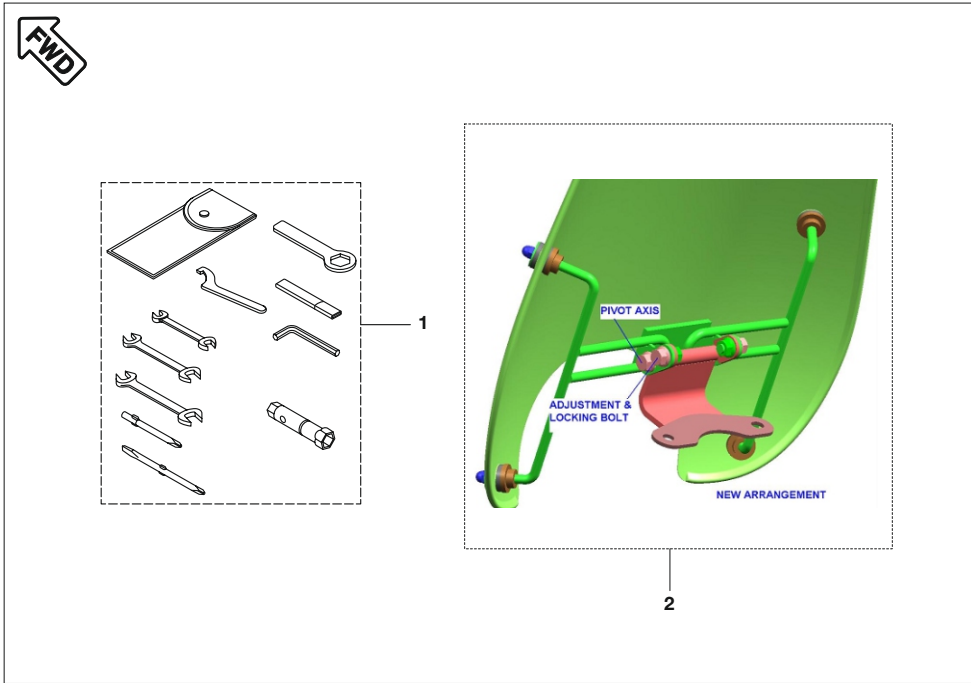

No.	Part No.	Description	Qty/ Veh.	Remarks
1	JM 2210 03	Tool Kit	1	
2	52 JM00 18	Wind Shield Kit	1	
3	JM 1810 06	Frame Wind Shield	1	
4	DD 2010 11	Rubber Damper	4	

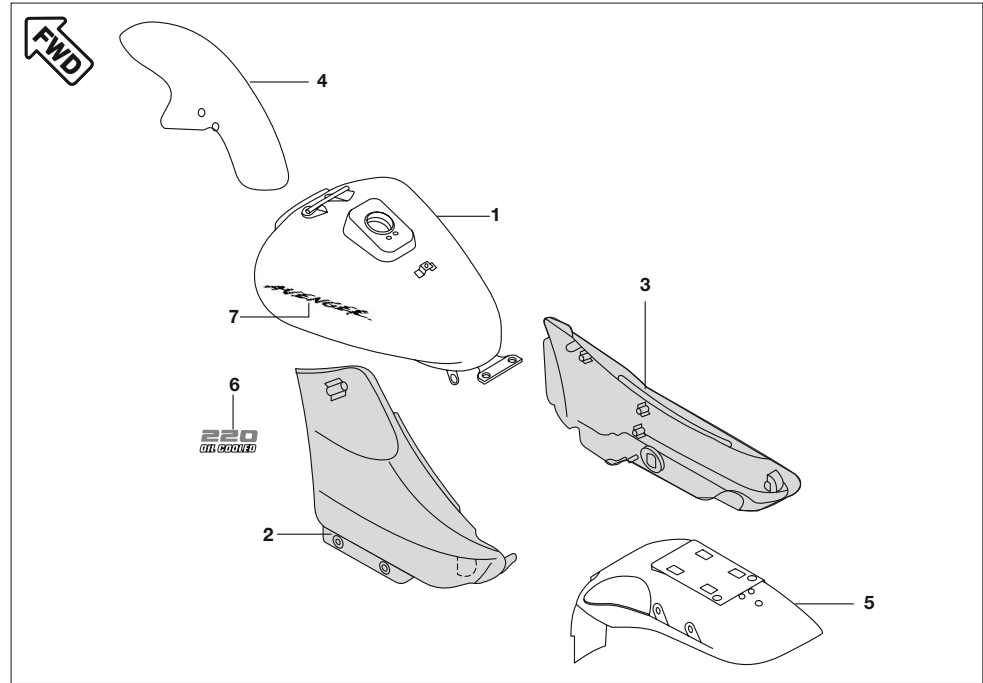

No.	Part No.	Description	Qty/ Veh.	Remarks
1	JM 7101 4M	Tank fuel with decal	1	Black
	JM 7101 4L	Tank fuel with decal	1	Silver
	JM 7101 2V	Tank fuel with decal	1	Red
	JM 7101 4K	Tank fuel with decal	1	Blue
	PD 7101 23	Tank Fuel Primered	1	No Color
2	JM 7301 4M	Cover side left with decal	1	Black
	JM 7301 4L	Cover side left with decal	1	Silver
	DV 7301 2V	Cover side left with decal	1	Red
	JM 7301 4K	Cover side left with decal	1	Blue
	52 DG01 91	Cover Side LH (Semi Finished)	1	No Color
3	JM 7302 4M	Cover side right with decal	1	Black
	JM 7302 4L	Cover side right with decal	1	Silver N.S
	DV 7302 2V	Cover side right with decal	1	Red
	JM 7302 4K	Cover side right with decal	1	Blue
	52 DG01 92	Cover Side RH (Semi Finished)	1	No Color

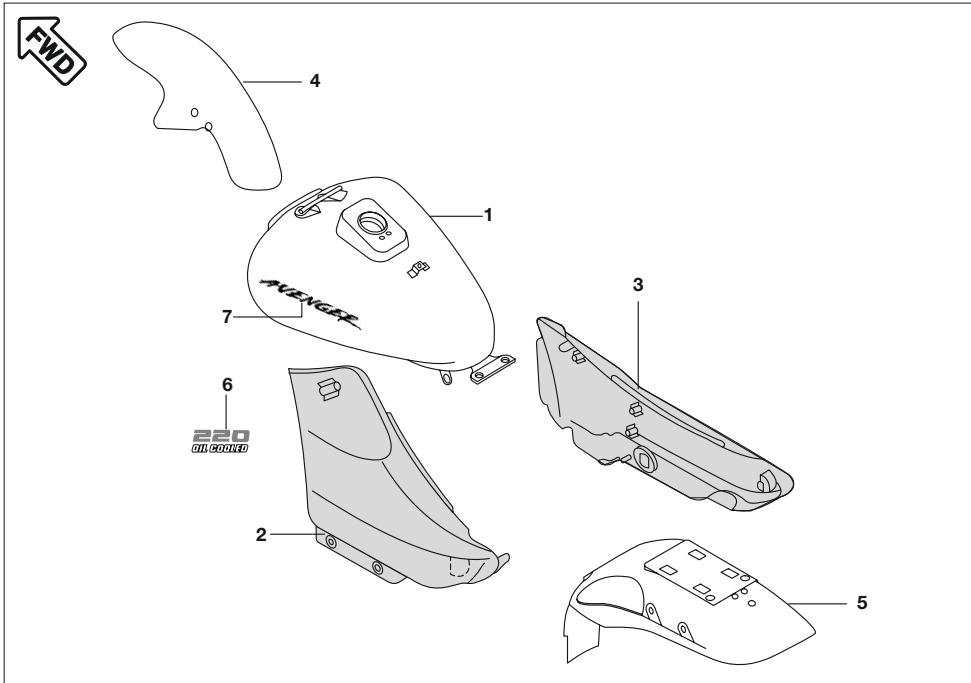

No.	Part No.	Description	Qty/ Veh.	Remarks
4	JM 1612 4M	Fender assly. front	1	Black
	JM 1612 4L	Fender assly. front	1	Silver
	JM 1612 2V	Fender assly. front	1	Red N.S
	JM 1612 4K	Fender assly. front	1	Blue
	52 DG02 88	Fender assly. front	1	No Color
5	JM 7401 4M	Fender rear	1	Black
	JM 7401 4L	Fender rear	1	Silver
	JM 7401 2V	Fender rear	1	Red
	DV 7304 2V	Fender rear	1	Red alt for JM 7401 2V
	JM 7401 4K	Fender rear	1	Blue
6	PD 1812 00	Oil Cooled decal	1	
	PD 1812 01	Oil Cooled decal	1	
7	JM 1410 06	Tank Decal	1	

Sr. No.	Kit Part No.	Kit Description	Consisting of Following Parts		
			Part No.	Discription	Qty./Kit
1	36DS1001	Cyl.Head O Ring Kit	39239121	O Ring (Cover tappet)	2
			39128321	O ring	2
2	DK101327	Valve Kit	DK101052	Valve Intake	1
			DK101011	Valve Exhaust	1
3	DK101326	Valve Repair Kit	DK101247	Retainer valve spring	2
			DK101108	Spring valve inner	2
			DK101110	Spring valve outer	2
			DK101246	Seat valve spring	2
4	DK101330	Guide Chain Kit	DK101060	Guide chain (Tight)	1
			DK101059	Guide Chain (slack)	1
5	36DK0038	Set primary Drive/Driven	DK101561	Clutch Housing	1
			DH101628	Gear Primary Drive	1
6	36DK0007	Kit Centrifugal Oil Filter	39220011	Washer	1
			DH101234	Gasket Centrifugal Oil Filter	1
			39226701	Oval Screw	3
			DH101066	Join Oil Deliver	1
			DH101067	Spring Oil Deliver	1
7	PD351205	H.T.Coil Kit	PD351201	H.T.Coil LH	1
			PD351202	H.T.Coil RH	1
8	36DV0007	Steering cone kit	DG181045	Bearing Cone Upper	1
			DG181046	Bearing race Upper	1
			DG181047	Bearing race Lower	1
			DG181005	Bearing Cone Lower	1
9	36PD0003	Chain Sprocket Kit	PD131200	Sprocket (38 T)	1
			JM151002	Chain	1
			DV101048	Sprocket	1

KIT LIST FOR



Sr. No.	Kit Part No.	Kit Description	Consisting of Following Parts		
			Part No.	Discription	Qty./Kit
11	DK101328	Ring Set Piston	DK101049	Top Ring	1
			DK101050	Second Piston ring	1
			DK101051	Ring Piston	1
12	36PD0005	Fork Seal kit Tube	DG181021	Seal fork outer Tube	1
			DG181023	Seal oil fork outer Tube	1
			DG181022	Ring Snap	1
13	36PD0004	Kit Hardware saree guard	39194004	Bolt Flanged	1
			39181404	Bolt Flanged	1
			39194104	Bolt Flanged	1
14	DJ101369	Friction Clutch Plate Kit	DK101566	Disc Clutch friction	4
			DK101568	Disc Clutch friction (B type)	1
			DK101567	Disc Clutch friction (C type)	1

AMENDMENT SHEET



Page no.	Fig. no.	Old part no.	New part no.	Description	Updation date	Remarks
4	6	PD511229	DS101276	SPROCKET CAMSHAFT	29.04.16	REF. CIR. IB-224
6	6	PD531029	DK101248	CRANKSHAFT SPROCKET	29.04.16	REF. CIR. IB-224

AMENDMENT SHEET



Page no.	Fig. no.	Old part no.	New part no.	Description	Updation date	Remarks

PART INDEX



Part No.	Figure No.	Page No.	Part No.	Figure No.	Page No.	Part No.	Figure No.	Page No.
DP161145	4	34	JC101114	3	27	JM71014M	1	61
DS101026	2	1	JC101115	8	27	JM73014K	2	61
DS101084	7	1	JC111026	2	25	JM73014L	2	61
DS101096	5	1	JC111028	1	25	JM73014M	2	61
DS101154	5	6	JC201036	20	30	JM73024K	3	61
DS101166	4	1	JE541212	9	17	JM73024L	3	61
DS101215	8	15	JM120005	15	22	JM73024M	3	61
DS101276	6	4	JM141002	22	49	JM74012V	5	62
DS101333	3	3	JM141006	7	62	JM74014K	5	62
DS101335	1	3	JM151005	6	38	JM74014L	5	62
DS101336	2	3	JM161002	6	29	JM74014M	5	62
DS101353	9	15	JM161003	7	29	JZ131605	3	37
DS101366	8	3	JM161004	5	29	KAAC0630	2	40
DV101034	15	11	JM161017	2	54	KACF0612	17	33
DV101035	14	23	JM161037	4	33	KBUA0612	13	40
DV101042	2	17	JM161037	1	40	KEBA3715	24	14
DV101044	3	11	JM16122V	4	62	LBU00008	14	40
DV101045	9	11	JM16124K	4	62	LEC00001	6	40
DV101048	22	9	JM16124L	4	62	PD111001	1	28
DV101056	16	23	JM16124M	4	62	PD111009	1	28
DV101057	13	23	JM171003	4	31	PD113000	2	33
DV121005	8	24	JM171004	1	31	PD113001	5	33
DV151005	28	39	JM181003	4	59	PD113002	11	33
DV161017	1	35	JM181006	3	60	PD113003	2A	33
DV161033	5	35	JM181007	4	44	PD113004	12	33
DV161036	10	58	JM181008	1	44	PD113400	8	29
DV161046	1	33	JM191007	2	52	PD113401	9	29
DV161060	9	35	JM191010	34	45	PD122000	2	31
DV171001	1	32	JM191011	4	40	PD122003	13	52
DV181001	15	46	JM191012	7	40	PD122004	14	52
DV181003	2	44	JM191013	8	40	PD131201	9	38
DV181008	5	44	JM191013	3	52	PD171000	2	48
DV181013	5	46	JM191014	15	40	PD181200	6	62
DV191002	4	52	JM191015	12	40	PD181201	6	62
DV191004	5	52	JM201002	1	58	PD231205	16	33
DV191006	11	52	JM201004	23	49	PD231206	3	33
DV191007	3	41	JM201012	15	58	PD351200	8	25
DV191007	12	52	JM201019	12	51	PD351205	10	25
DV191008	4	51	JM201028	1	57	PD401000	2	56
DV201006	16	58	JM201029	2	57	PD401001	2	56
DV201010	16	55	JM201030	3	57	PD401400	3	59
DV201016	8	58	JM201031	8	57	PD401401	12	44
DV221001	5	50	JM201032	4	58	PD401402	7	59
DV73012V	2	61	JM221001	13	44	PD401404	28	45
DV73022V	3	61	JM221002	14	44	PD401408	7	59
DV73042V	5	62	JM221003	1	60	PD401409	12	44
DZ161265	9	34	JM221004	30	45	PD402001	9	58
GF201050	5	51	JM221005	31	45	PD402002	13	25
JB401013	12	58	JM221006	32	45	PD402003	14	25
JC101040	20	16	JM71012V	1	61	PD402200	7	58
JC101085	4	4	JM71014K	1	61	PD402202	7	58
JC101086	3	4	JM71014L	1	61	PD402207	2	52

PART INDEX



Part No.	Figure No.	Page No.	Part No.	Figure No.	Page No.	Part No.	Figure No.	Page No.
PD402208	7	58						
PD402209	7	58						
PD402210	7	58						
PD402600	26	49						
PD501000	1	12						
PD509000	12	2						
PD509001	7	24						
PD511229	6	4						
PD531029	6	6						
PD571200	1	21						
PD571201	3	21						
PD571203	4	21						
PD581000	1	24						
PD581200	1	22						
PD581202	2	22						
PD581203	3	22						
PD581204	5	22						
PD581205	4	22						
PD581206	6	22						
PD581207	7	22						
PD581208	8	22						
PD581211	12	22						
PD581212	13	22						
PD581401	6	2						
PD591005	1	23						
PD591100	17	23						
PD591101	15	23						
PD710123	1	61						

PART INDEX



Part No.	Figure No.	Page No.	Part No.	Figure No.	Page No.	Part No.	Figure No.	Page No.

PART INDEX



Part No.	Figure No.	Page No.	Part No.	Figure No.	Page No.	Part No.	Figure No.	Page No.